

# Repair Parts

**C** C O U N T R Y  
**CLIPPER**  
Z E R O T U R N M O W E R

**B O S S**<sup>XL</sup> 9005

**SERIAL RANGE: 21286001 - \_\_\_\_\_**

**COUNTRY CLIPPER**  
**BOSS XL-9005**  
**SERIAL RANGE 21286001 - \_\_\_\_\_**  
**ZERO TURN RADIUS MOWER**  
**TABLE OF CONTENTS**

**SECTION 1 – MOWER DECKS AND RELATED PARTS**

1. 60" DECK ASSEMBLY
2. 72" DECK ASSEMBLY
3. DISCHARGE CHUTE ASSEMBLY
4. DECK SPINDLE ASSEMBLY
5. DECK IDLER
6. DECK LIFT ASSEMBLY & RELATED PARTS
7. DECK LIFT ASSEMBLY & RELATED PARTS (CON'T)
8. CUT HEIGHT ASSEMBLY & RELATED PARTS
9. JACK ASSEMBLY

**SECTION 2 – TRACTOR FRAME AND RELATED PARTS**

10. PIVOTING FRONT AXLE
11. FRONT STEP & FOOT PAN
12. FRONT PANEL ASSEMBLY
13. RH FENDER & RELATED PARTS
14. LH FENDER & RELATED PARTS
15. ENGINE GUARD
16. ROPS
17. SEAT
18. SEAT BASE

**SECTION 3 – TRACTOR DRIVE AND RELATED PARTS**

19. FUEL TANK ASSEMBLY
20. JOYSTICK CONTROL & RELATED PARTS
21. JOYSTICK ASSEMBLY
22. JOYSTICK ASSEMBLY MOUNTING & RELATED PARTS
23. TWIN LEVER CONTROL & RELATED PARTS
24. TWIN LEVER ASSEMBLY
25. CONTROL PANEL – KAWASAKI
26. BRAKE
27. TRANSMISSION ASSEMBLY & RELATED PARTS
28. HYDRO MOUNT
29. HYDRO IDLER
30. DOUBLE IDLER
31. TIRES
32. BATTERY
33. ENGINES
34. ENGINE & CLUTCH MOUNTING & RELATED PARTS
35. WIRE HARNESS & RELATED PARTS (CARBURETED)
36. WIRE HARNESS SCHEMATIC (CARBURETED)
37. WIRE HARNESS & RELATED PARTS (EFI)
38. WIRE HARNESS SCHEMATIC (EFI)

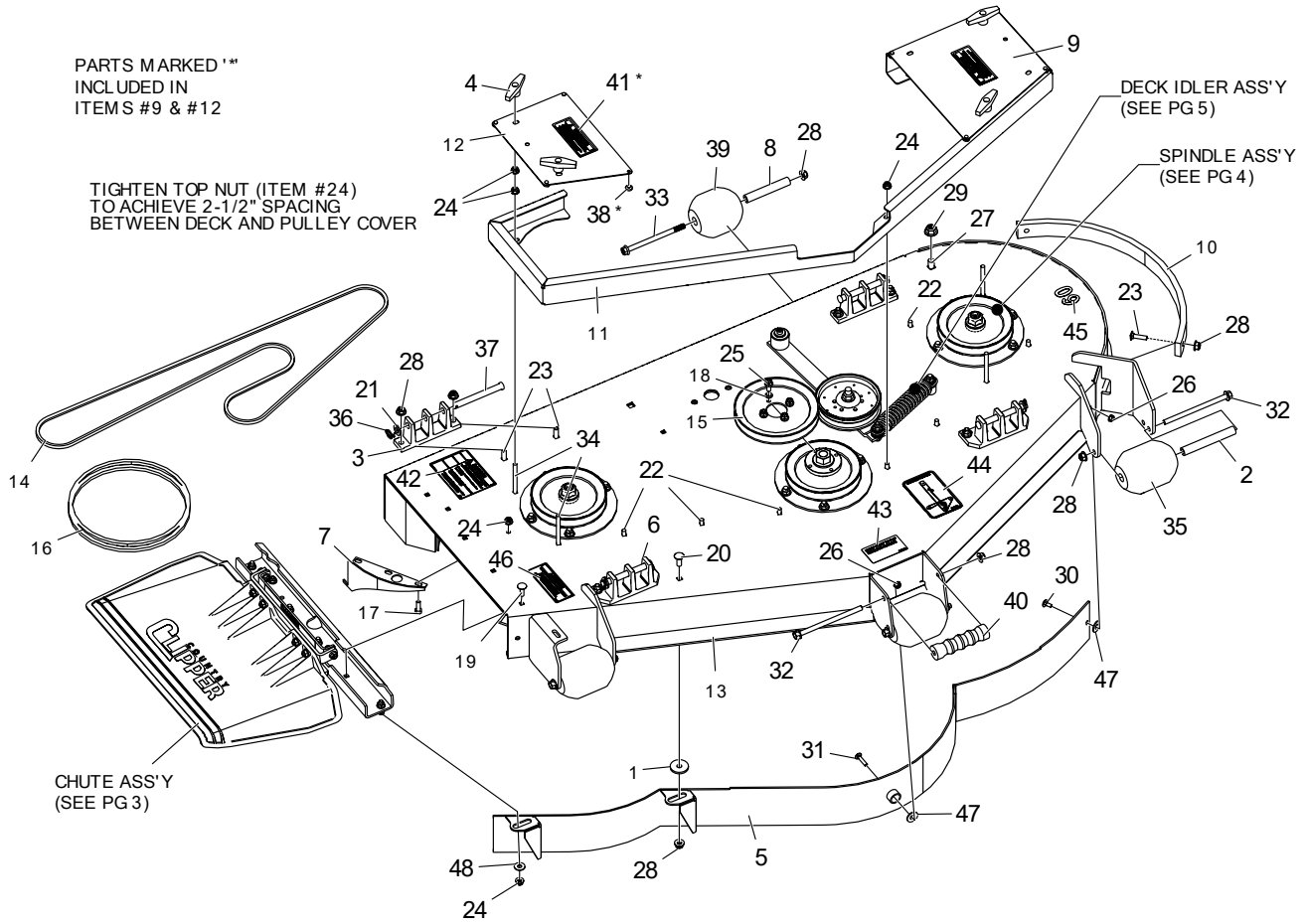

Item #	Qty	Part #	Description
1	1	609-034P	SPINDLE SPACER WASHER
2	3	609-183P	BUSHING
3	2	643-016W	DECK HANGER, NARROW BASE
4	4	643-072A	T-HANDLE ASSY W/ NUT
5	1	643-104W	60" DUST BAFFLE WELDMENT
6	2	651-009W	DECK HANGER, WIDE BASE
7	1	686-006W	SPLITTER WELDMENT
8	2	714-133P	BUSHING, ROLLER BRACKET
9	1	629-961A	PULLEY COVER ASS'Y, TRIM
10	1	730-015P	PLASTIC WEAR STRIP
11	1	730-020P	TOP STIFFENER, 60
12	1	629-964A	PULLEY COVER ASS'Y, DISCHARGE
13	1	629-965A	60" DECK W/ DECALS
14	1	D-3796	V-BELT B-124 DAYCO #7-9537, DECK
15	1	D-4073	PULLEY, CENTER, 60
16	1	D-4075	V-BELT, B-109, KEVLAR, ENGINE TO DECK
17	1	F-1015-15	HHCS, 5/16-18 X 1", YZ, GR5
18	4	F-1019-02	LOCKWASHER, HVY, 5/16, YZ
19	1	F-1106	BOLT, CARRIAGE, 5/16-18 X 1-1/4, YZ, GR5
20	1	F-1274	CARRIAGE BOLT, 3/8 X 1", YZ, GR5
21	4	F-1521	WASHER, 1/2" CUSTOM, YZ
22	7	F-1671	CARRIAGE BOLT, 5/16-18 X 3/4", YZ, GR5
23	10	F-1672	BOLT, CARRIAGE, 3/8-16 X 1-1/4", YZ, GR5
24	17	F-2063	NUT, 5/16-18, NYLOC, FLANGED, YZ

Item #	Qty	Part #	Description
25	4	F-2120	FHCS, 5/16-18 X 3/4", YZ, GR5
26	2	F-2132	NUT, 1/4-20 NYLOC, FLANGED, YZ
27	1	F-2146	CARRIAGE BOLT, 1/2-13 X 1", YZ, GR5
28	17	F-2151	NUT, 3/8-16 NYLOC, FLANGED, YZ
29	1	F-2152	NUT, 1/2-13 NYLOC, FLANGED, YZ
30	1	F-2155	BOLT, CARRIAGE, 1/4-20 X 5/8", YZ, GR5
31	1	F-2157	BOLT, CARRIAGE, 1/4-20 X 1-1/4", YZ, GR5
32	4	F-2161	FHCS, 3/18-16 X 6" YZ, GR5
33	2	F-2222	FHCS, 3/8-16 X 5-1/2", YZ, GR5
34	4	F-2298	CARRIAGE BOLT, 5/16-18 X 3-1/2"
35	3	H-1948	ROLLER, 3-3/4 DIA
36	4	H-2239	1/2" RUE RING
37	4	H-2240	1/2" X 4-1/2" CLEVIS PIN
38	8	H-3188	RUBBER BUMPER
39	2	H-2768	ROLLER, 3-3/4 DIA. X 4"
40	1	H-2787	GRIP, DECK HANDLE
41	2	P-10935	DECAL, "WARNING ROTATING DRIVE"
42	1	P-10941	DECAL, DANGER
43	1	P-11413	DECAL, HOIST POINT
44	1	P-11935	DECAL, BELT ROUTING
45	1	P-11952	DECAL, DECK SIZE, 60
46	1	P-12706	WARNING DECAL, DISCHARGE CHUTE
47	2	F-1009-01	FLAT WASHER, 1/4", YZ
48	1	F-1009-02	WASHER, FLAT

PARTS MARKED '\*\*'  
INCLUDED IN  
ITEMS #9 & #10

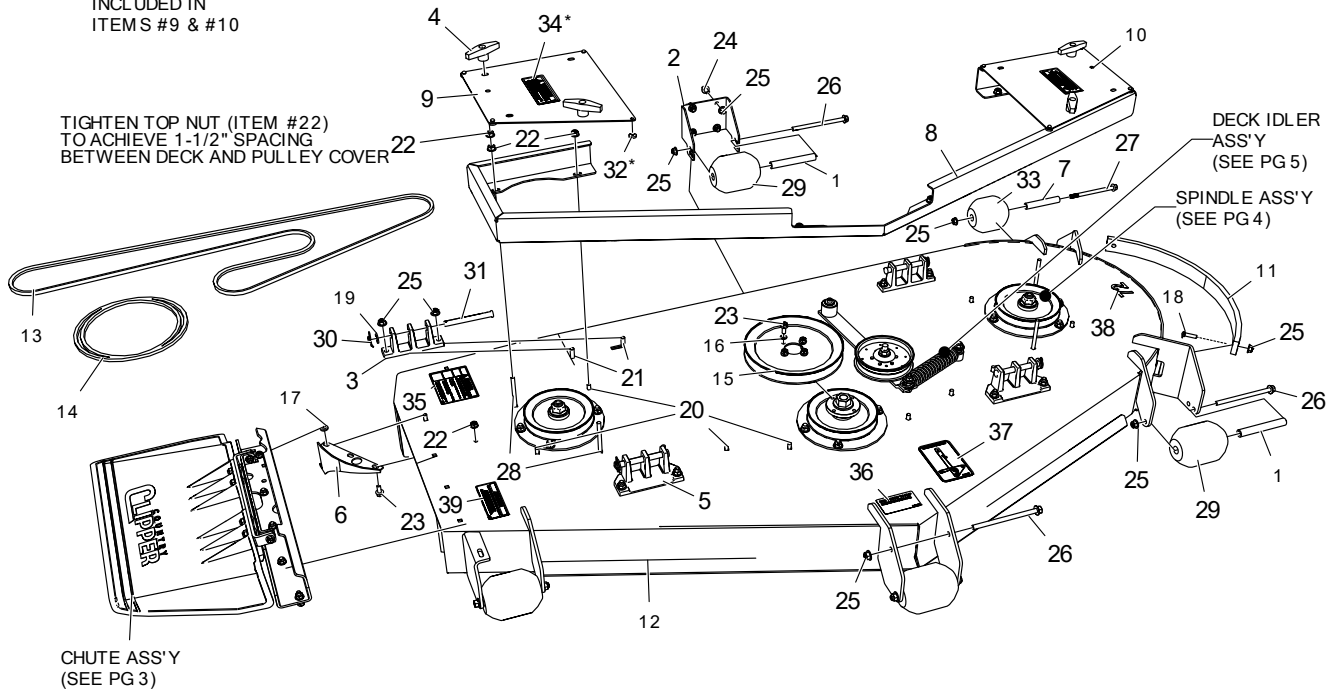

Item #	Qty	Part #	Description
1	4	609-183P	BUSHING
2	1	637-006P	BRACKET, REAR ROLLER
3	2	643-016W	DECK HANGER, NARROW BASE
4	4	643-072A	T-HANDLE ASSY W/ NUT
5	2	651-009W	DECK HANGER, WIDE BASE
6	1	686-006W	SPLITTER WELDMENT
7	2	714-133P	BUSHING, ROLLER BRACKET
8	1	730-002P	TOP STIFFENER, 72
9	1	629-962A	PULLEY COVER ASS'Y, DISCHARGE
10	1	629-961A	PULLEY COVER ASS'Y, TRIM
11	1	730-015P	PLASTIC WEAR STRIP
12	1	629-963A	72" DECK W/ DECALS
13	1	D-3797	V-BELT B-142 DAYCO #7-9535, DECK
14	1	D-3902	V- BELT, B-116", ENGINE TO DECK
15	1	D-4072	PULLEY, CENTER, 72
16	4	F-1019-02	LOCKWASHER, HVY, 5/16, YZ
17	1	F-1019-03	LOCKWASHER, HVY, 3/8, YZ
18	2	F-1106	BOLT, CARRIAGE, 5/16-18 X 1-1/4, YZ, GR5
19	4	F-1521	WASHER, 1/2" CUSTOM, YZ
20	10	F-1671	CARRIAGE BOLT, 5/16-18 X 3/4", YZ, GR5

Item #	Qty	Part #	Description
21	8	F-1672	BOLT, CARRIAGE, 3/8-16 X 1-1/4", YZ, GR5
22	19	F-2063	NUT, 5/16-18, NYLOC, FLANGED, YZ
23	5	F-2120	FHCS, 5/16-18 X 3/4", YZ, GR5
24	4	F-2124	FHCS, 3/8-16 X 3/4", YZ, GR5
25	21	F-2151	NUT, 3/8-16 NYLOC, FLANGED, YZ
26	5	F-2161	FHCS, 3/18-16 X 6" YZ, GR5
27	2	F-2222	FHCS, 3/8-16 X 5-1/2", YZ, GR5
28	4	F-2298	CARRIAGE BOLT, 5/16-18 X 3-1/2"
29	4	H-1948	ROLLER, 3-3/4 DIA
30	4	H-2239	1/2" RUE RING
31	4	H-2240	1/2" X 4-1/2" CLEVIS PIN
32	8	H-3188	RUBBER BUMPER
33	2	H-2768	ROLLER, 3-3/4 DIA. X 4"
34	2	P-10935	DECAL, "WARNING ROTATING DRIVE"
35	1	P-10941	DECAL, DANGER
36	1	P-11413	DECAL, HOIST POINT
37	1	P-11935	DECAL, BELT ROUTING
38	1	P-11953	DECAL, DECK SIZE, 72
39	1	P-12706	WARNING DECAL, DISCHARGE CHUTE

DISCHARGE CHUTE ASSEMBLY  
& RELATED PARTS

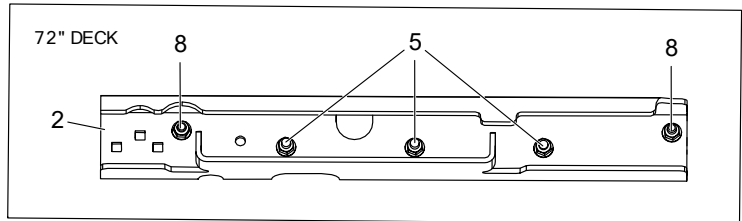
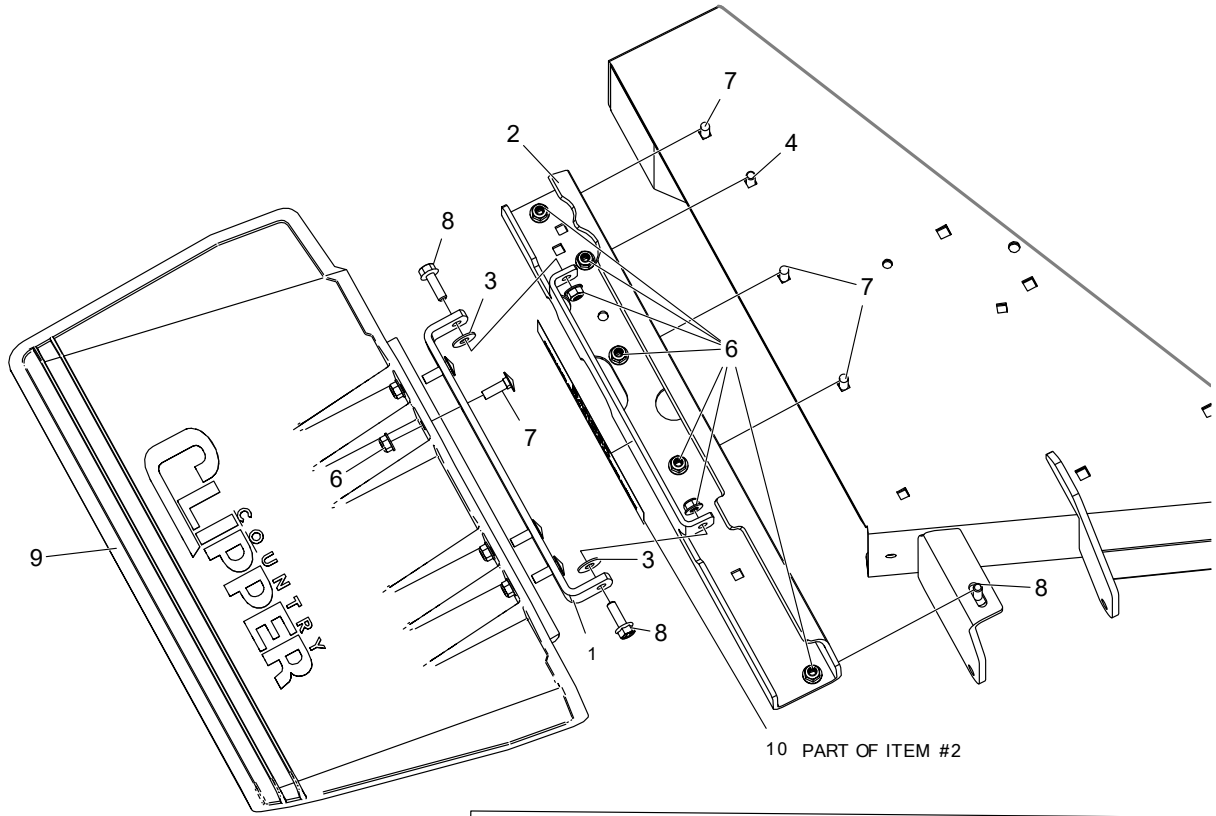

Item #	Qty	Part #	Description
1	1	643-110P	CHUTE HINGE
2	1	643-135A	OUTLET STIFFENER W/DECALS, SMALL
3	2	F-1009-02	WASHER, FLAT
4	1	F-1015-15	HHCS, 5/16-18 X 1", YZ, GR5
5	3	F-1671	BOLT, CARRIAGE, 5/16-18 X 3/4", YZ, GR5
6	11	F-2063	NUT, 5/16-18, NYLOC, FLANGED, YZ
7	7	F-2066	BOLT, CARRIAGE, 5/16-18 X 1", YZ, GR5
8	4	F-2148	FHCS, 5/16-18 X 1", YZ, GR5
9	1	H-2723	CHUTE
10	1	P-12496	DECAL, CHUTE MISSING

BOSS XL  
(9005)

DECK SPINDLE ASSEMBLY  
{629JY-001A}

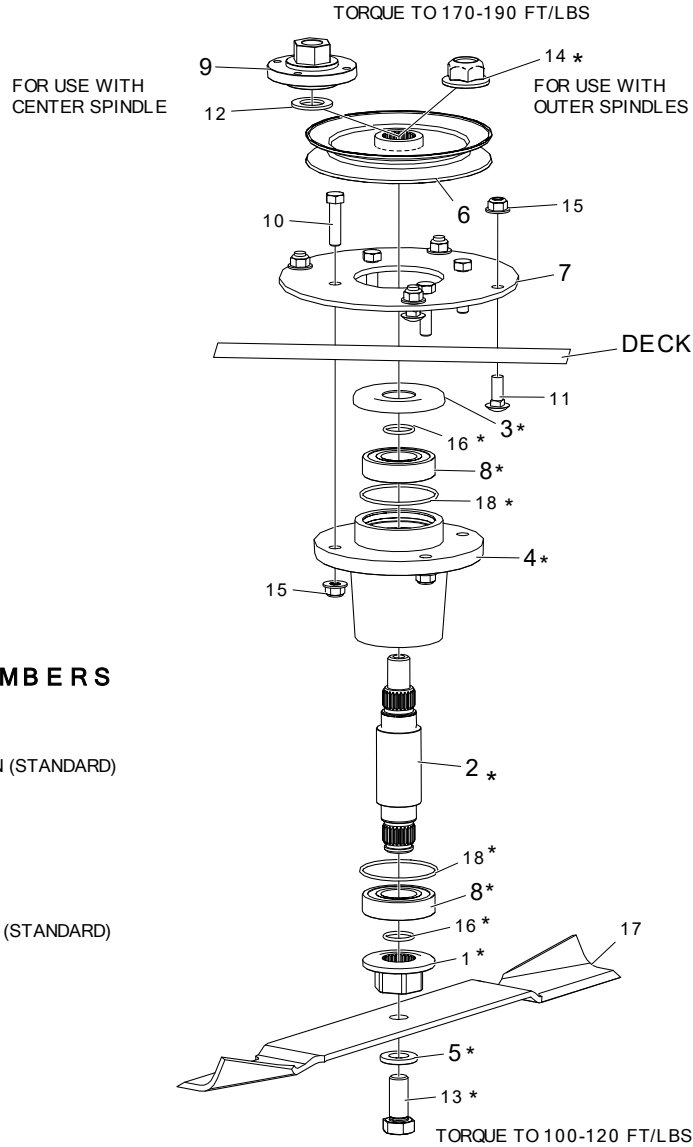

PARTS MARKED '\*'  
ARE PART OF  
COMPLETE  
ASSEMBLY

**BLADE PART NUMBERS**

**60" DECK**

- H-2886 HIGH LIFT W/ FUSION (STANDARD)
- H-2885 HIGH LIFT
- H-2661 LOW LIFT
- H-2667 GATOR

**72" DECK**

- H-2887 HIGH LIFT W/ FUSION (STANDARD)
- H-2656 HIGH LIFT
- H-2662 LOW LIFT
- H-2877 GATOR

Item #	Qty	Part #	Description
1	1	609-288P	DRIVER, BLADE, FRICTION, SPL
2	1	609-289P	SHAFT, SPINDLE, HD
3	1	609-292P	CAP, BEARING
4	1	609-302P	HSG, SPINDLE, HD
5	1	660-099P	WASHER, BLADE, 5/8
6	1	668-042P	PULLEY, 5.676PD, "B", SPLINE
7	1	730-006P	WASHER PLATE, REINFORCEMENT
8	2	D-3867	BRG, BALL, 6206, F-SEALS
9	1	D-4071	HUB, PULLEY, TOP, BOLTED

Item #	Qty	Part #	Description
10	4	F-1015-27	HHCS, 3/8-16 X 1-1/2", YZ, GR5
11	4	F-1274	CARRIAGE BOLT, 3/8 X 1", YZ, GR5
12	1	F-1510	WASHER, FLAT, 3/4"
13	1	F-2073	HHCS, 5/8-11 X 1-1/2", GR8, YZ
14	1	F-2078	NUT, 3/4-16, TOP LOCK, GR-GT, YZ
15	8	F-2151	NUT, 3/8-16 NYLOC, FLANGED, YZ
16	2	H-2639	O-RING, -117, 70 DURO
17	1	-----	BLADE, SEE LISTING ABOVE
18	2	H-3178	O-RING, SPINDLE, HSG

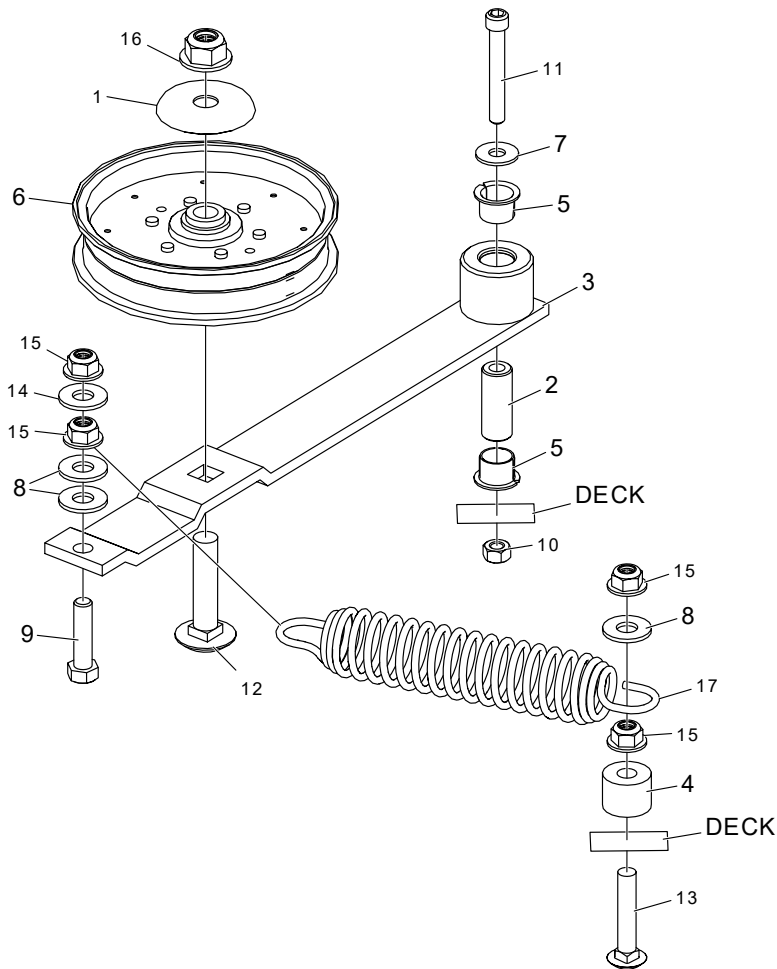

Item #	Qty	Part #	Description
1	1	620-201P	WASHER, BEARING CAP
2	1	621-103P	MOUNTING PIN
3	1	643-078W	SINGLE IDLER ARM LONG WLDT
4	1	668-045P	SPACER, SPRING MTG
5	2	D-3730	BUSHING, DU 5/8 DIA X 1/2 LG
6	1	D-3904	PULLEY, FLAT IDLER, 5"
7	1	F-1009-02	WASHER, FLAT
8	3	F-1009-03	WASHER, FLAT, 3/8, YZ
9	1	F-1015-27	HHCS, 3/8-16 X 1-1/2", YZ, GR5
10	1	F-1125	NUT, CENTERLOCK, 5/16-18, YZ, GR5
11	1	F-1800	SHCS, 5/16-18 X 2-1/4", YZ, GR5
12	1	F-1822	BOLT, CARRIAGE, 1/2-13 X 2-1/4", YZ, GR5
13	1	F-1976	BOLT, CARRIAGE, 3/8-16 X 2", YZ, GR5
14	1	F-2083	WASHER, FENDER, 3/8"
15	4	F-2151	NUT, 3/8-16 NYLOC, FLANGED, YZ
16	1	F-2152	NUT, 1/2-13 NYLOC, FLANGED, YZ
17	1	H-2619	SPRING, 5 X 1-1/2, TAPERED ENDS

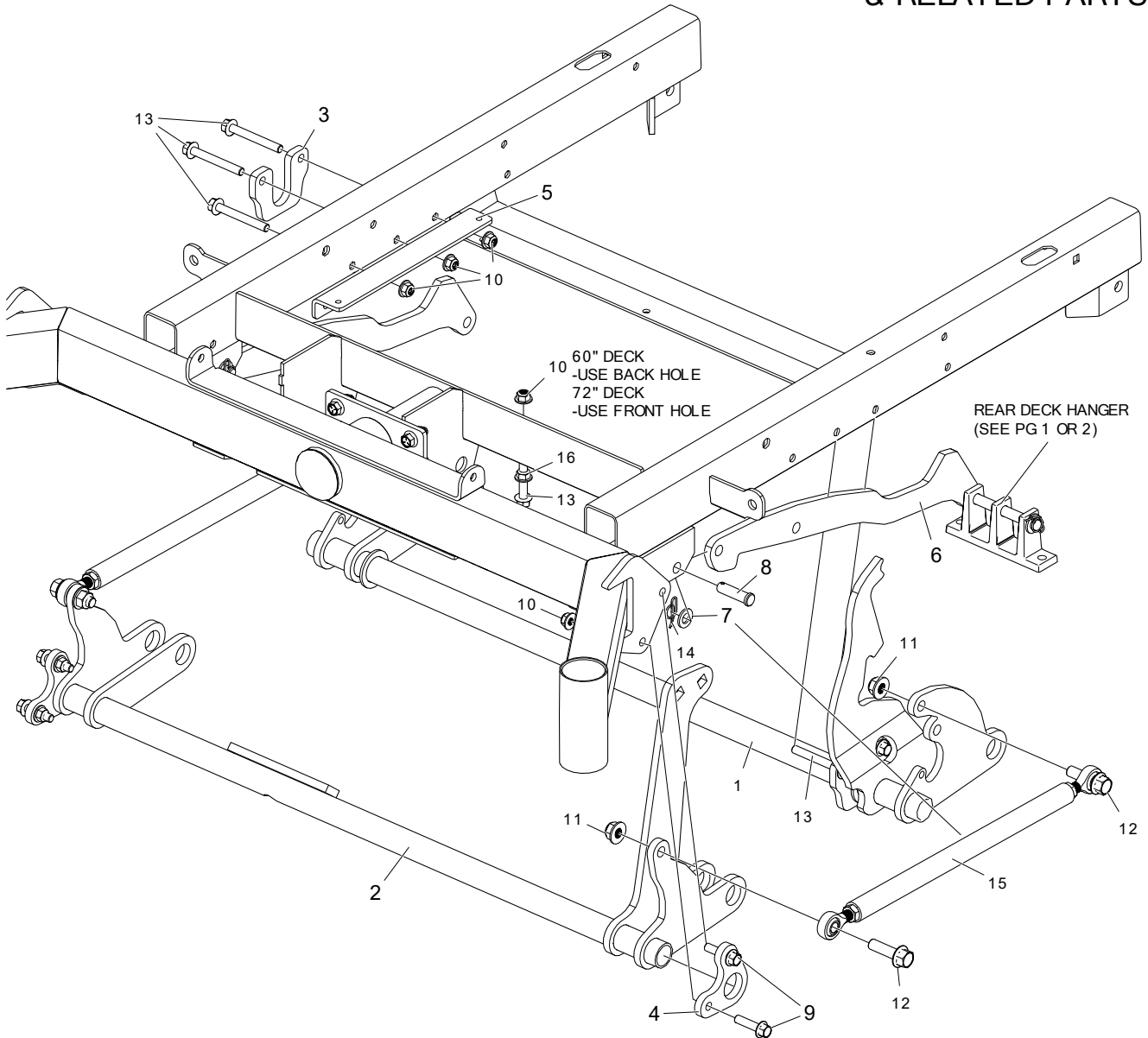

Item #	Qty	Part #	Description
1	1	724-021W	WLDT, DECK LIFT, REAR
2	1	724-026W	WLDT, DECK LIFT, FRONT
3	2	724-032P	DECK PIVOT MOUNT PLATE
4	2	724-033P	DECK SUSPENSION FRONT PLATE
5	2	724-045P	FLOOR PAN SUPPORT ANGLE
6	2	724-117P	DRAG BAR
7	2	F-1521	WASHER, 1/2" CUSTOM, YZ
8	2	F-1896	CLEVIS PIN, 1/2 X 1-3/4", YZ
9	4	F-2147	FHCS, 3/8-16 X 1-1/2", YZ, GR5
10	10	F-2151	NUT, 3/8-16 NYLOC, FLANGED, YZ
11	4	F-2152	NUT, 1/2-13 NYLOC, FLANGED, YZ
12	4	F-2154	FHCS, 1/2-13 x 1-3/4", YZ, GR5
13	6	F-2180	FHCS, 3/8-16 x 3", YZ, GR5
14	2	H-2239	1/2" RUE RING
15	2	H-3153	DECK LIFT LINKAGE
16	1	F-1486	JAM NUT, 3/8-16



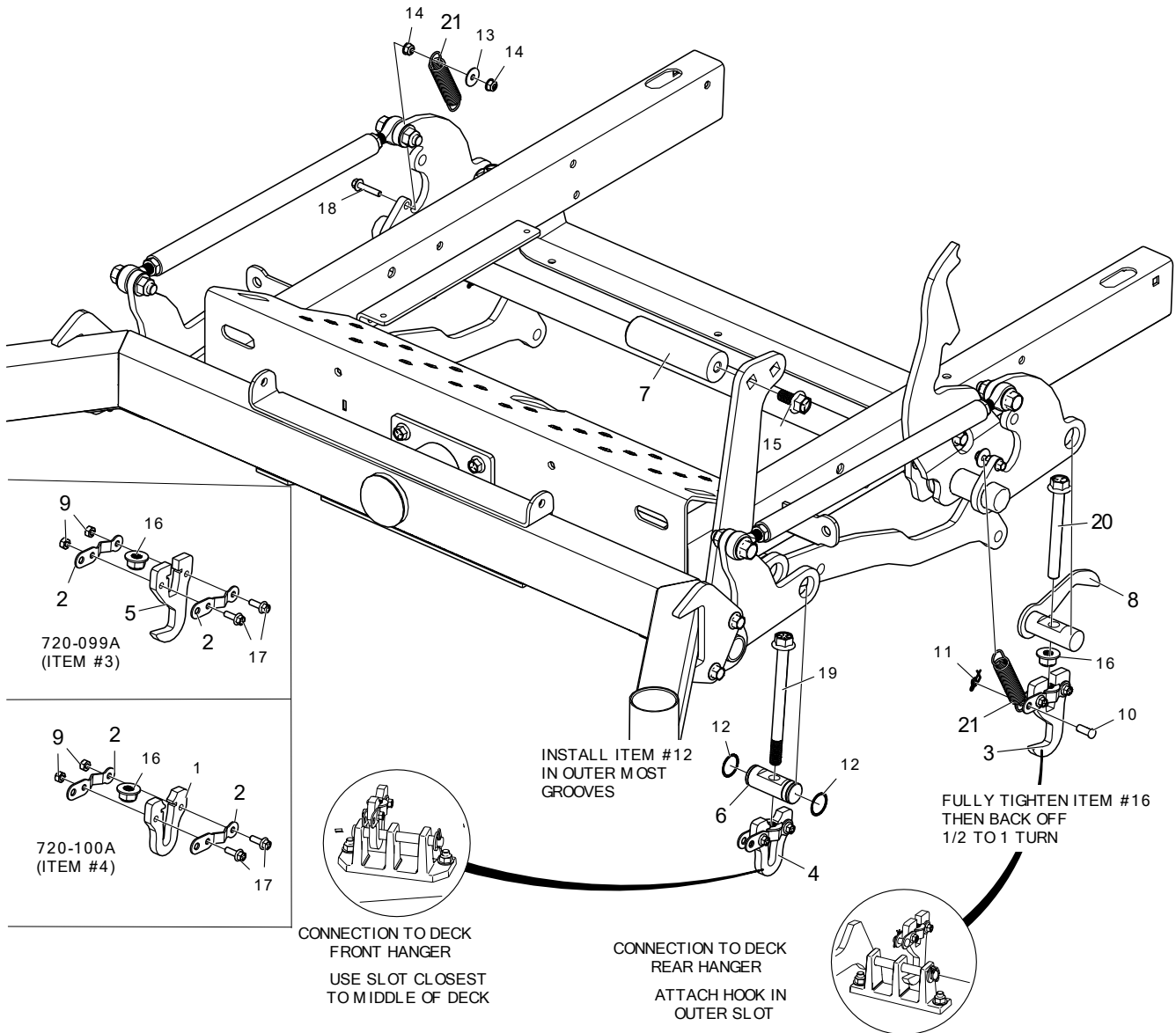

Item #	Qty	Part #	Description
1	1	720-097P	DECK HANGER, FRONT
2	4	720-098P	NUT RETAINER
3	1	720-099A	ASS'Y, DECK HANGER, REAR
4	1	720-100A	ASS'Y, DECK HANGER, FRONT
5	1	720-115P	HOOK, REAR DECK
6	2	724-052P	HANGER PIN, FRONT
7	1	724-084P	FOOT PEG
8	1	724-091W	HANGER PIN WLDT, REAR LH
-	1	724-092W	HANGER PIN WLDT, REAR RH
9	4	F-1158	NUT, CENTERLOCK, 1/4-20, YZ, GR5
10	2	F-1443	CLEVIS PIN, 5/16 X 7/8"

Item #	Qty	Part #	Description
11	2	F-1492	RUE RING, 5/16
12	4	F-1998	SPIROL RING 1"
13	2	F-2097	WASHER, FENDER, 0.25 X 0.875
14	4	F-2132	NUT, 1/4-20 NYLOC, FLANGED, YZ
15	1	F-2143	FHCS, 1/2-13 X 1", YZ, GR5
16	4	F-2152	NUT, 1/2-13 NYLOC, FLANGED, YZ
17	4	F-2162	FHCS, 1/4-20 X 3/4", YZ, GR5
18	2	F-2182	FHCS, 1/4-20 X 1-1/4", YZ, GR5
19	2	F-2301	FHCS, 1/2-13 X 5-1/2", YZ, GR5
20	2	F-2302	FHCS 1/2-13 X 4", GR5, YZ, FULL THREAD
21	2	H-1635	SPRING, EXT, 3/4" OD X 4" OAL

BOSS XL  
(9005)

CUT HEIGHT ASSEMBLY  
& RELATED PARTS

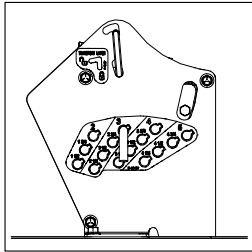

INSIDE VIEW OF CUT HEIGHT SUB-ASSEMBLY, SHOWING DECALS

CUT HEIGHT SUB-ASSEMBLY  
(SEE DETAIL)

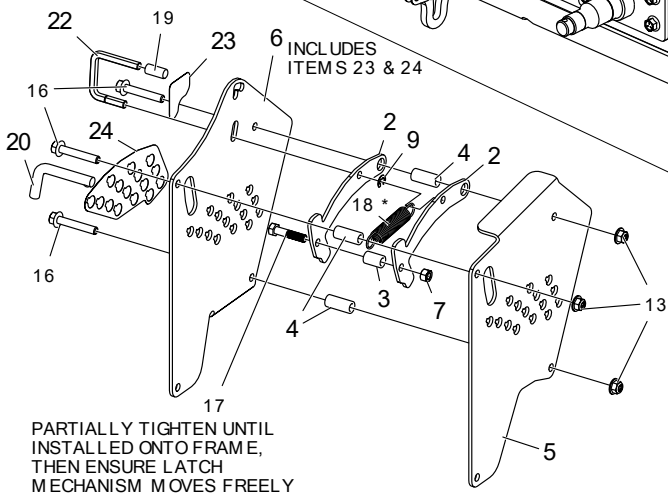
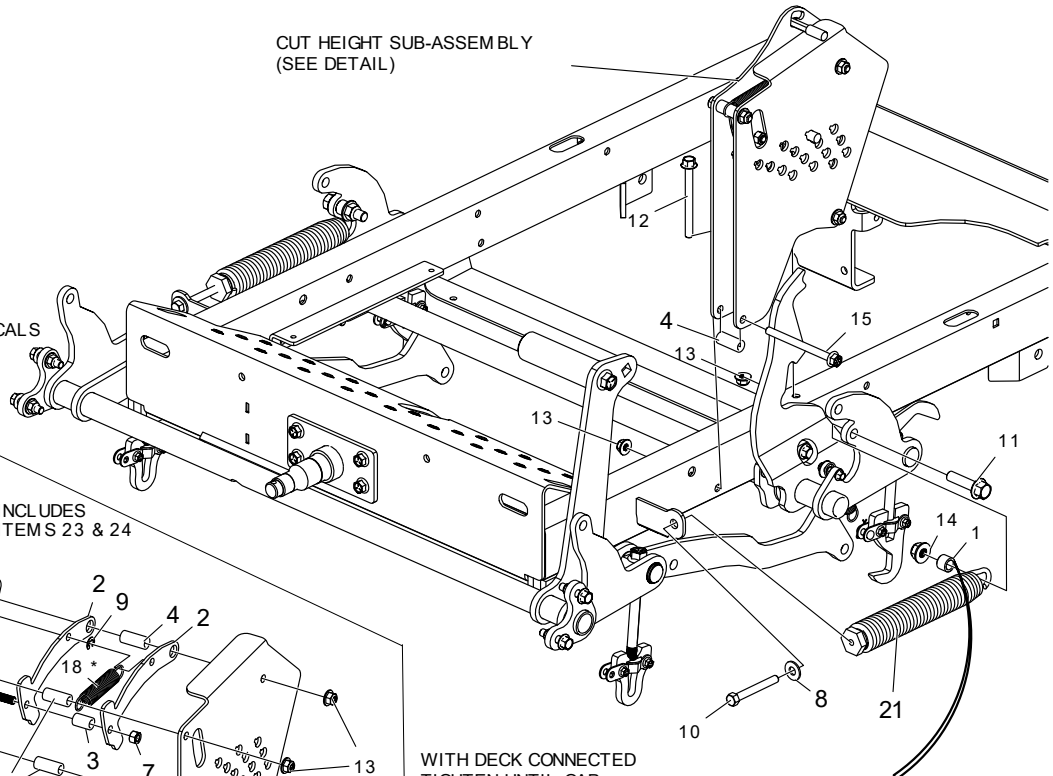

PARTIALLY TIGHTEN UNTIL  
INSTALLED ONTO FRAME,  
THEN ENSURE LATCH  
MECHANISM MOVES FREELY

\*ATTACH SPRING TO HANDLE (H-3120) FIRST  
THEN TO SPACER (724-080P)

CUT HEIGHT SUB-ASSEMBLY

WITH DECK CONNECTED  
TIGHTEN UNTIL GAP  
BETWEEN TAB ON FRAME  
AND SPRING IS  
APPROXIMATELY  
0.75" - 60" DECKS  
0.50" - 72" DECKS

HOOK SPRING WITH OPENING  
FACING DOWN - LEFT SIDE  
FACING UP - RIGHT SIDE

Item #	Qty	Part #	Description
1	2	720-010P	CLAMP EXTENSION
2	2	724-042P	CATCH PLATE
3	1	724-079P	SPACER, CATCH PLATE
4	4	724-080P	SPACER, CUT HEIGHT PLATE
5	1	724-095P	PLATE, CUT HEIGHT, OUTER
6	1	629-972A	PLATE, CUT HEIGHT, INNER W/ DECALS
7	1	F-1005-03	NUT, 3/8-16, CENTERLOCK, YZ, GR5
8	2	F-1009-03	WASHER, FLAT, 3/8, YZ
9	1	F-1080	SNAP RING
10	2	F-1329	SCREW, 3/8-16 X 3 GR5 FULL THREADED
11	2	F-2154	FHCS, 1/2-13 X 1-3/4", YZ, GR5
12	1	F-2142	FHCS, 3/8-16 X 4", YZ, GR5

Item #	Qty	Part #	Description
13	5	F-2151	NUT, 3/8-16 NYLOC, FLANGED, YZ
14	2	F-2152	NUT, 1/2-13 NYLOC, FLANGED, YZ
15	1	F-2160	FHCS, 3/8-16 X 4-1/2", YZ, GR5
16	3	F-2218	FHCS, 3/8-16 X 2-1/4", YZ, GR5
17	1	F-2260	HHCS, 3/8-16 X 1-3/4", YZ, GR8
18	1	H-1635	SPRING, EXT, 3/4" OD X 4" OAL
19	1	H-2327	3/8 DIA X 1" LONG END CAP
20	1	H-3013	DECK HEIGHT PIN
21	2	H-3117	EXTENSION SPRING W/THREADED PLUG
22	1	H-3120	TRANSPORT LATCH RELEASE HANDLE
23	1	P-13437	DECAL, TRANSPORT LATCH
24	1	P-13477	DECAL, CUT HEIGHT

STANDARD EQUIPMENT  
ON 72" MODELS ONLY

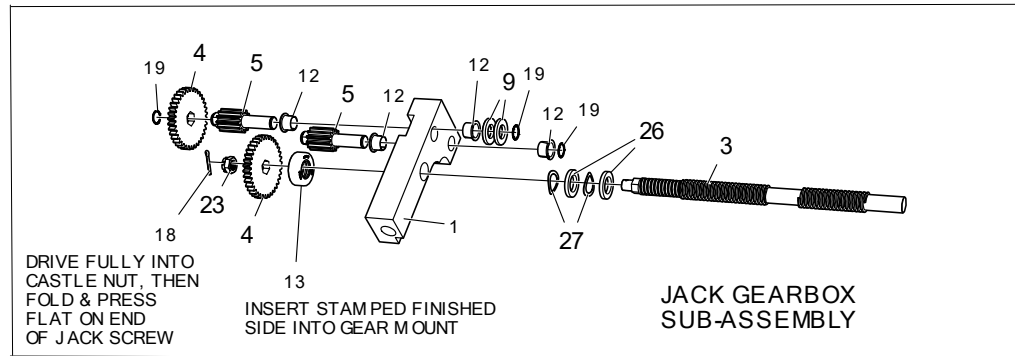

TIGHTEN BOLT & NUT TO A SNUG FIT, THEN LOOSEN 1/2 TURN JOINT MUST PIVOT FREELY BOTH SIDES (TYP)

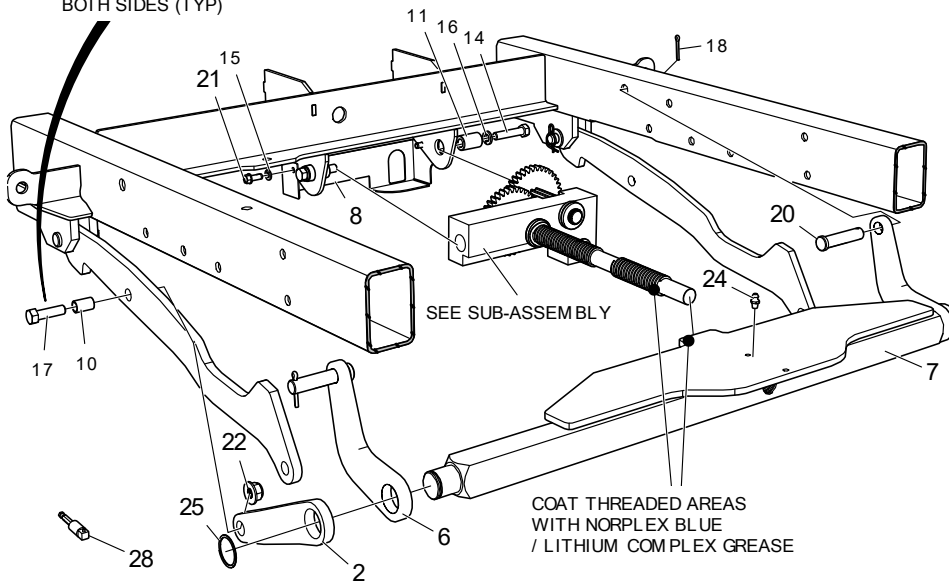

Item #	Qty	Part #	Description
1	1	629-936P	JACK GEAR MOUNT
2	2	629-941P	JACK SCISSOR ARM - OFFSET
3	1	629-945P	JACK SHAFT
4	2	629-946P	SPUR GEAR, 36 TOOTH
5	2	629-947P	GEAR, PINION
6	2	629-949P	JACK SCISSOR ARM, CURVED
7	1	629-991W	JACK CROSS SHAFT WLDT
8	1	629-959P	JACK GEAR SHIELD
9	2	660-099P	WASHER, BLADE, 5/8
10	2	707-073P	STAND-OFF, LINKAGE MOUNT
11	2	721-068P	SPACER, 1.135 LONG
12	4	D-3730	BUSHING, DU 5/8 DIA X 1/2 LG
13	1	D-4022	BEARING, THRUST
14	2	F-1015-28	HHCS, 3/8-16 X 1-3/4", YZ, GR5

Item #	Qty	Part #	Description
15	2	F-1019-01	WASHER, LOCK, 1/4, YZ
16	2	F-1019-03	LOCKWASHER, HVY, 3/8, YZ
17	2	F-2125	FHCS, 3/8-16 X 1-1/4", YZ, GR5
18	3	F-1491	COTTER PIN, 1/8 X 1
19	3	F-1739	5/8 SPIRAL RETAINING RING
20	2	F-1897	PIN, CLEVIS 1/2 X 2-1/4" LG Y-D
21	2	F-2030	1/4 X 5/8", SELF-TAPPING HEX SCREW
22	2	F-2151	NUT, 3/8-16 NYLOC, FLANGED, YZ
23	1	F-2236	CASTLE NUT, 1/2-20
24	1	H-1056	1/4" GREASE FITTING
25	2	F-1998	SPIROL RING 1"
26	2	H-3177	WASHER, OVERSIZED
27	2	H-3179	CURVED DISC SPRING
28	1	T-10038	3/8 SQUARE DRIVE, SHANK ADAPTER

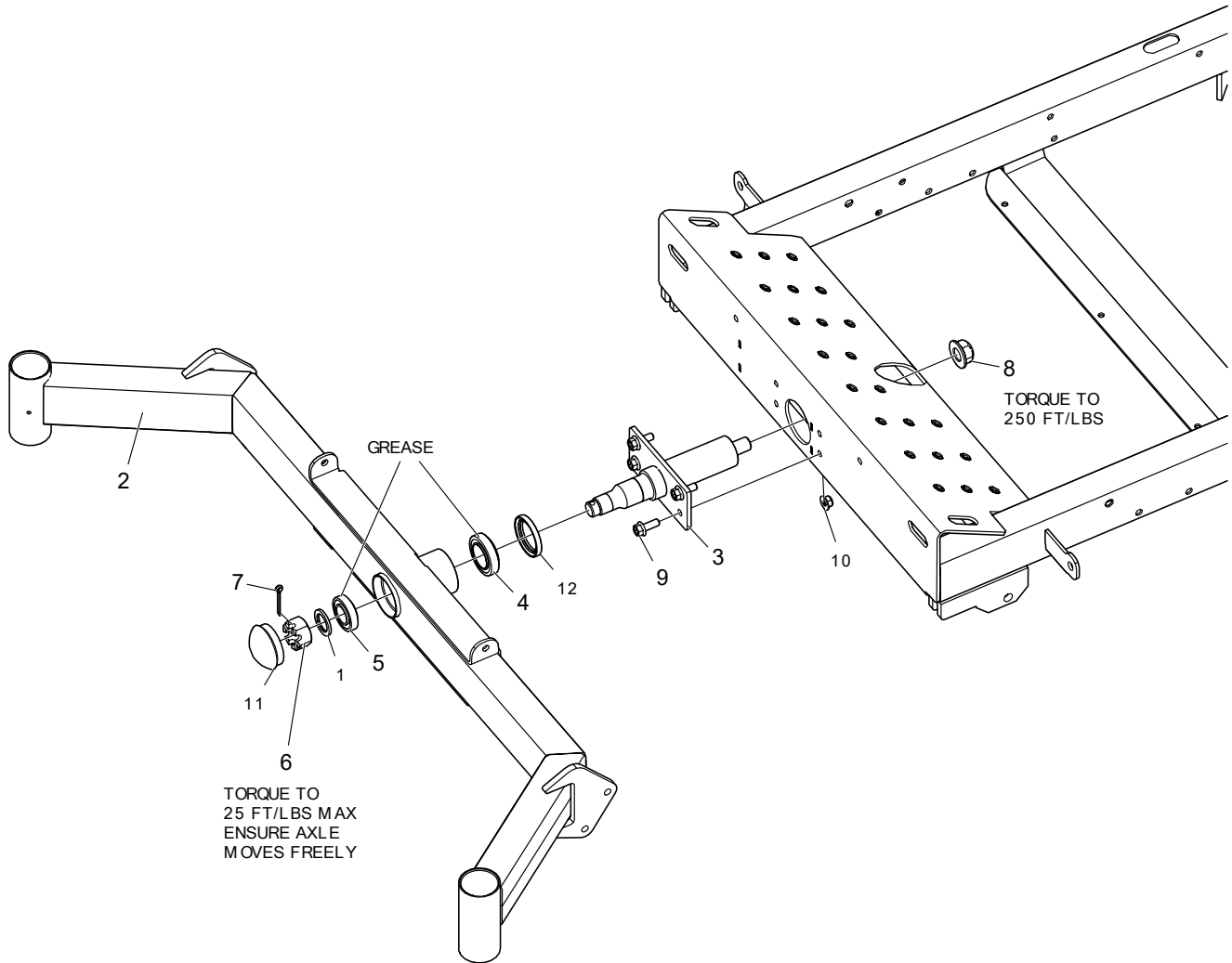

Item #	Qty	Part #	Description
1	1	606-303P	WASHER, 10GA GALVANIZED
2	1	724-164W	WLDT, FRONT AXLE
-	1	724-165W	WLDT, FRONT AXLE, 72
3	1	724-056W	WLDT, PIVOT SHAFT
4	1	D-3825	BRG, TAPERED, SET, L68149-L68110
5	1	D-3826	BRG, TAPERED, SET, L44643-L44610
6	1	F-1724	NUT, HEX, SLOTTED, 1-14, YZ
7	1	F-1728	COTTER PIN, 3/16 X 2", YZ
8	1	F-2078	NUT, 3/4-16, TOP LOCK, GR-GT, YZ
9	4	F-2141	FHCS, 3/8-16 X 1", YZ, GR5
10	4	F-2151	NUT, 3/8-16 NYLOC, FLANGED, YZ
11	1	H-1924	GREASE CAP PLATED
12	1	H-2812	SEAL, SHAFT, 1.75, 2.38, 0.313

PARTS MARKED \*\* STANDARD  
ON 72" DECK MODELS ONLY

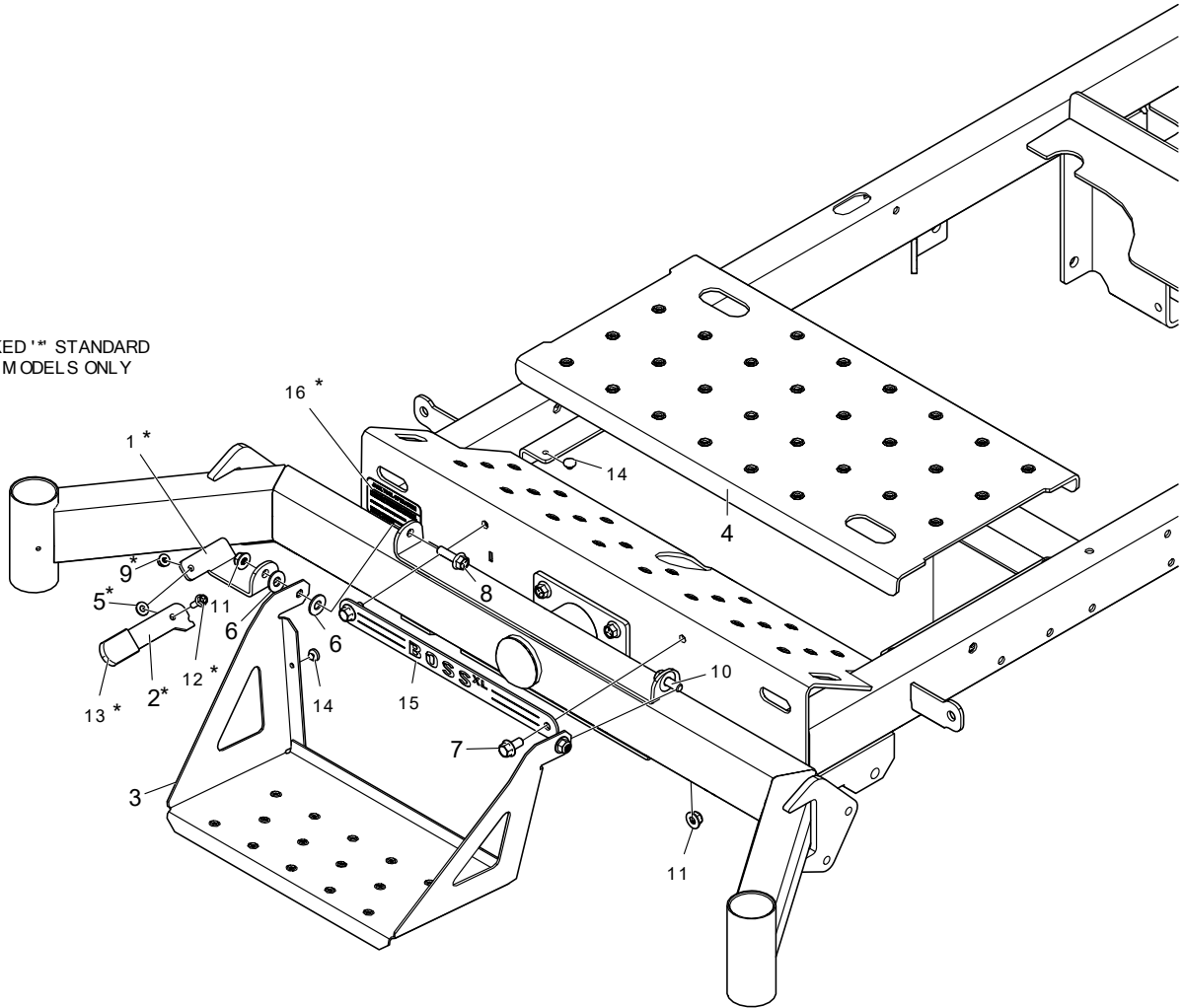

Item #	Qty	Part #	Description
1	1	629-958P	JACK - DRILL ANTI ROTATION STOP
2	1	629-983P	ANTI ROTATION PIVOT STOP
3	1	663-134P	STEP, EXTENDED
4	1	724-044P	FLOOR PAN
5	1	F-1009-01	FLAT WASHER, 1/4", YZ
6	3	F-1009-03	WASHER, FLAT, 3/8, YZ
7	2	F-2124	FHCS, 3/8-16 X 3/4", YZ, GR5
8	1	F-2125	FHCS, 3/8-16 X 1-1/4", YZ, GR5, 72" DECK
-	1	F-2141	FHCS, 3/8-16 X 1", YZ, GR5, 60" DECK
9	1	F-2132	NUT, 1/4-20 NYLOC, FLANGED, YZ
10	1	F-2141	FHCS, 3/8-16 X 1", YZ, GR5
11	4	F-2151	NUT, 3/8-16 NYLOC, FLANGED, YZ
12	1	F-2162	FHCS, 1/4-20 X 3/4", YZ, GR5
13	1	H-1850	GRIP, VINYL
14	6	H-2461	RUBBER BUMPER
15	1	H-2912	PLACARD, BOSS XL
16	1	P-13551	DECAL, JACK TOOL

BOSS XL  
(9005)

FRONT PANEL

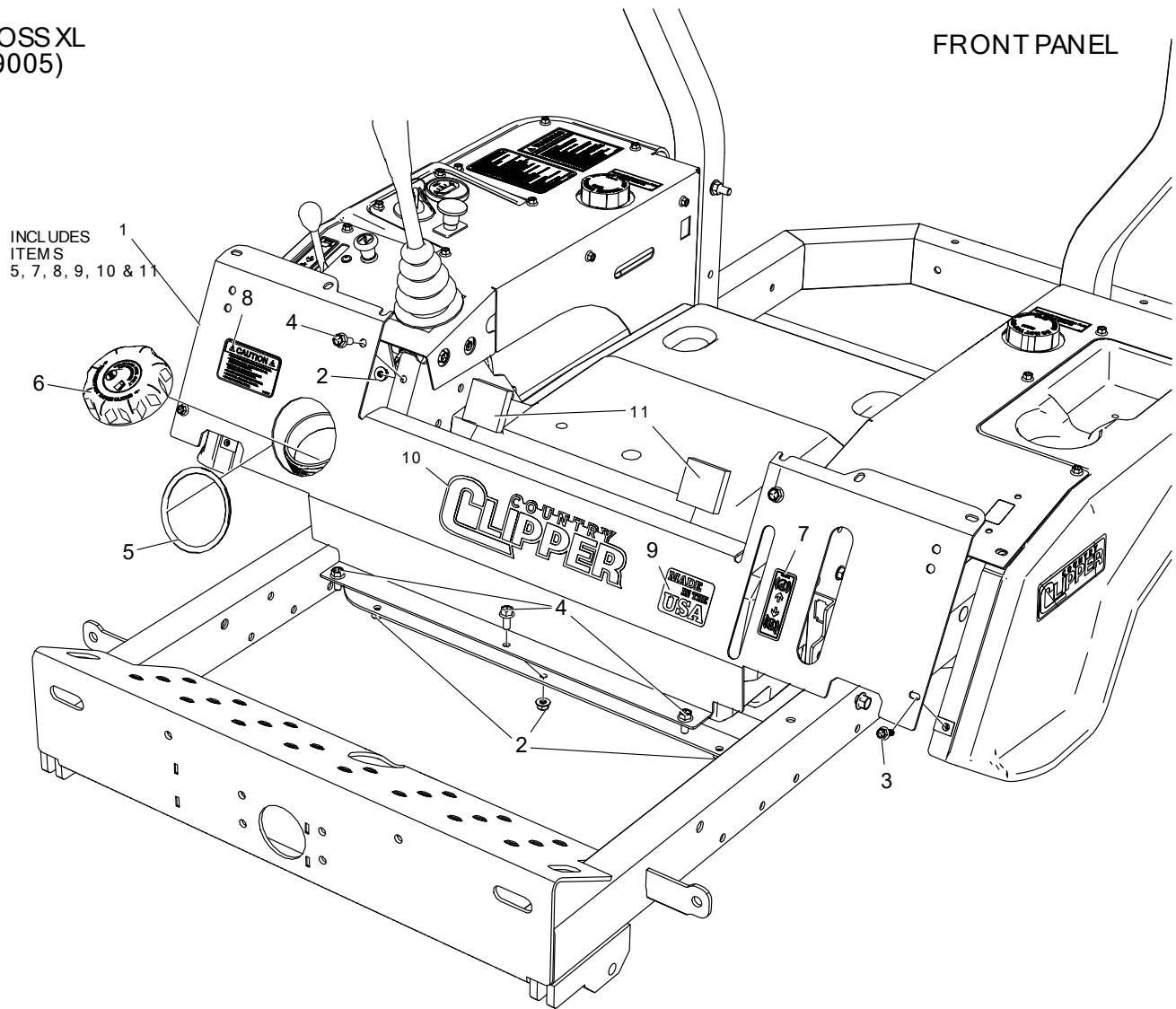

Item #	Qty	Part #	Description
1	1	629-971A	FRONT PANEL W/ DECALS
2	5	F-2063	NUT, 5/16-18, NYLOC, FLANGED, YZ
3	2	F-2119	FHCS, 1/4-20 X 3/4", YZ, GR5, LOCK PATCH
4	5	F-2120	FHCS, 5/16-18 X 3/4", YZ, GR5
5	1	H-1626	"U"-CHANNEL TRIM, 12.5"
6	1	H-2743	RATCHET CAP, W/TETHER, 3.5 DIA
7	1	P-11382	DECAL, PARK BRAKE
8	1	P-12557	DECAL, CAUTION FUEL
9	1	P-13000	DECAL, MADE IN THE USA
10	1	P-13312	DECAL, LOGO, CHROME w/BLK, LG
11	1	H-2990	WEATHER-RESISTANT NEOPRENE FOAM (ADHESIVE) 1/2"

BOSS XL  
(9005)

## RIGHT HAND FENDER & RELATED PARTS

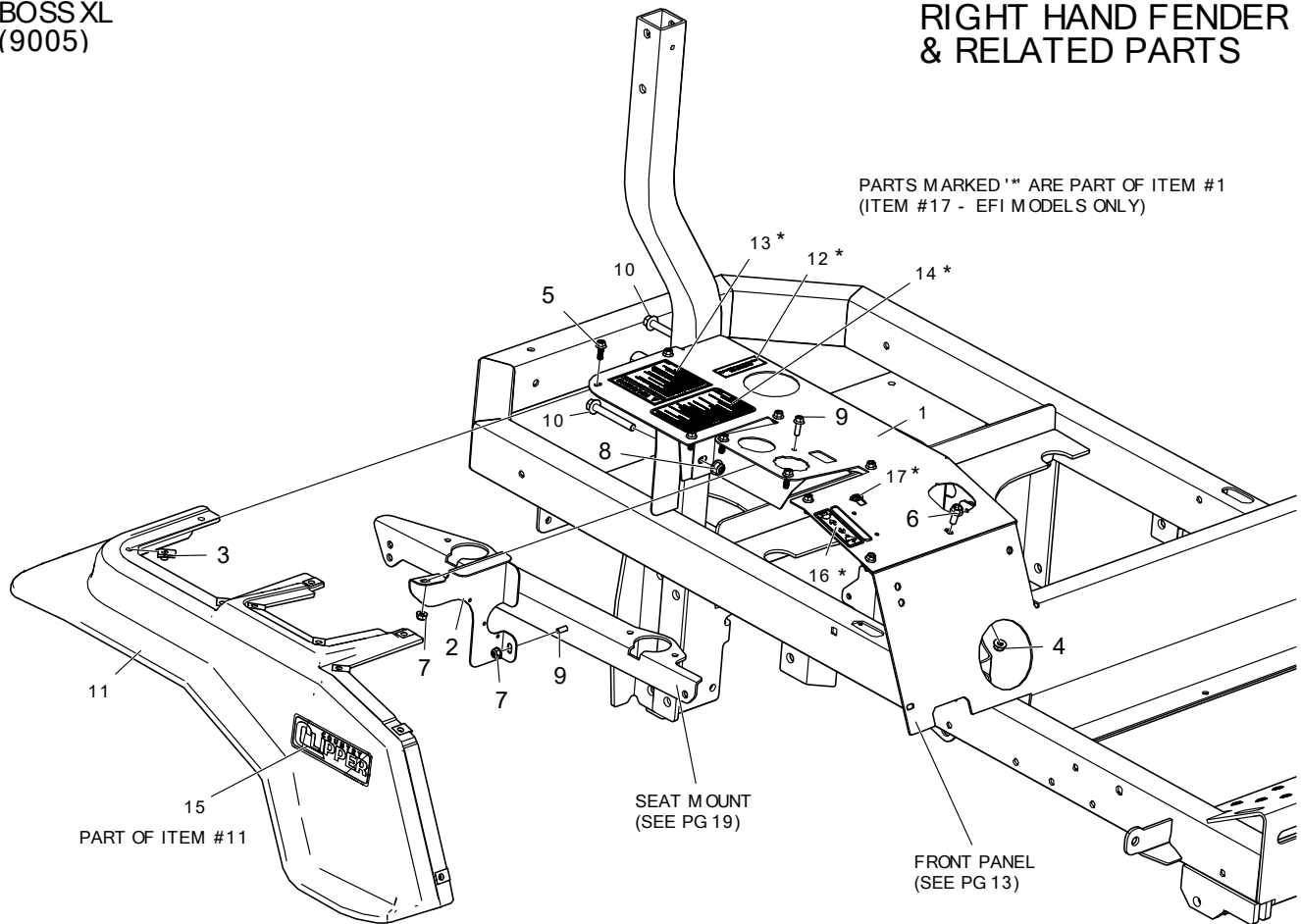

Item #	Qty	Part #	Description
1	1	629-973A	FENDER CAP W/ DECALS, JS, RH
-	1	629-978A	FENDER CAP W/ DECALS, TS, RH
-	1	629-980A	FENDER CAP W/ DECALS, JS, RH, EFI
-	1	629-981A	FENDER CAP W/ DECALS, TS, RH, EFI
2	1	724-152P	STIFFENER, CONTROL PANEL
3	9	F-1858	U-NUT, 1/4-20
4	1	F-2063	NUT, 5/16-18, NYLOC, FLANGED, YZ
5	9	F-2119	FHCS, 1/4-20 X 3/4", YZ, GR5, LOCK PATCH
6	1	F-2120	FHCS, 5/16-18 X 3/4", YZ, GR5
7	2	F-2132	NUT, 1/4-20 NYLOC, FLANGED, YZ
8	2	F-2151	NUT, 3/8-16 NYLOC, FLANGED, YZ
9	2	F-2162	FHCS, 1/4-20 X 3/4", YZ, GR5
10	2	F-2180	FHCS, 3/8-16 x 3", YZ, GR5
11	1	629-976A	FENDER SKIRT W/ DECAL, RH
12	1	P-11052	DECAL, "TRANSMISSION OIL..."
13	1	P-11370	DECAL, WARNING
14	1	P-13188	DECAL, INSTRUCTIONS
15	1	P-13366	DECAL, C/C LOGO, SM, VINYL
16	1	P-13481	DECAL, THROTTLE
17	1	P-13482	DECAL, ENGINE (EFI)

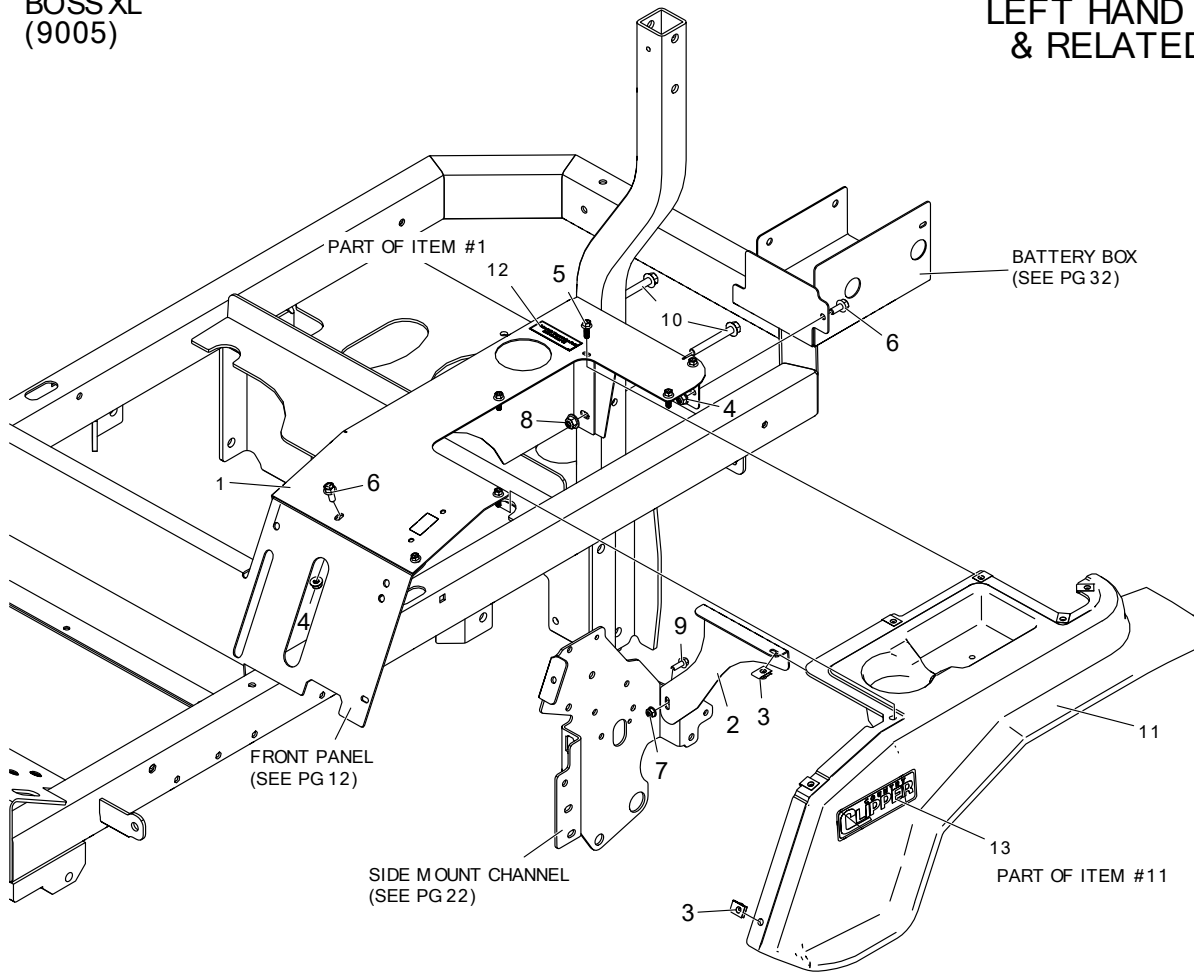

Item #	Qty	Part #	Description
1	1	629-974A	FENDER CAP W/ DECAL, JS, LH
-	1	629-979A	FENDER CAP W/ DECAL, TS, LH
2	1	724-155P	STIFFENER, FENDER CAP, LH
3	7	F-1858	U-NUT, 1/4-20
4	2	F-2063	NUT, 5/16-18, NYLOC, FLANGED, YZ
5	6	F-2119	FHCS, 1/4-20 X 3/4", YZ, GR5, LOCK PATCH
6	2	F-2120	FHCS, 5/16-18 X 3/4", YZ, GR5
7	1	F-2132	NUT, 1/4-20 NYLOC, FLANGED, YZ
8	2	F-2151	NUT, 3/8-16 NYLOC, FLANGED, YZ
9	1	F-2162	FHCS, 1/4-20 X 3/4", YZ, GR5
10	2	F-2180	FHCS, 3/8-16 x 3", YZ, GR5
11	1	629-975A	FENDER SKIRT W/ DECAL, LH
12	1	P-11052	DECAL, "TRANSMISSION OIL..."
13	1	P-13366	DECAL, C/C LOGO, SM, VINYL



BOSS XL  
(9005)

ENGINE GUARD

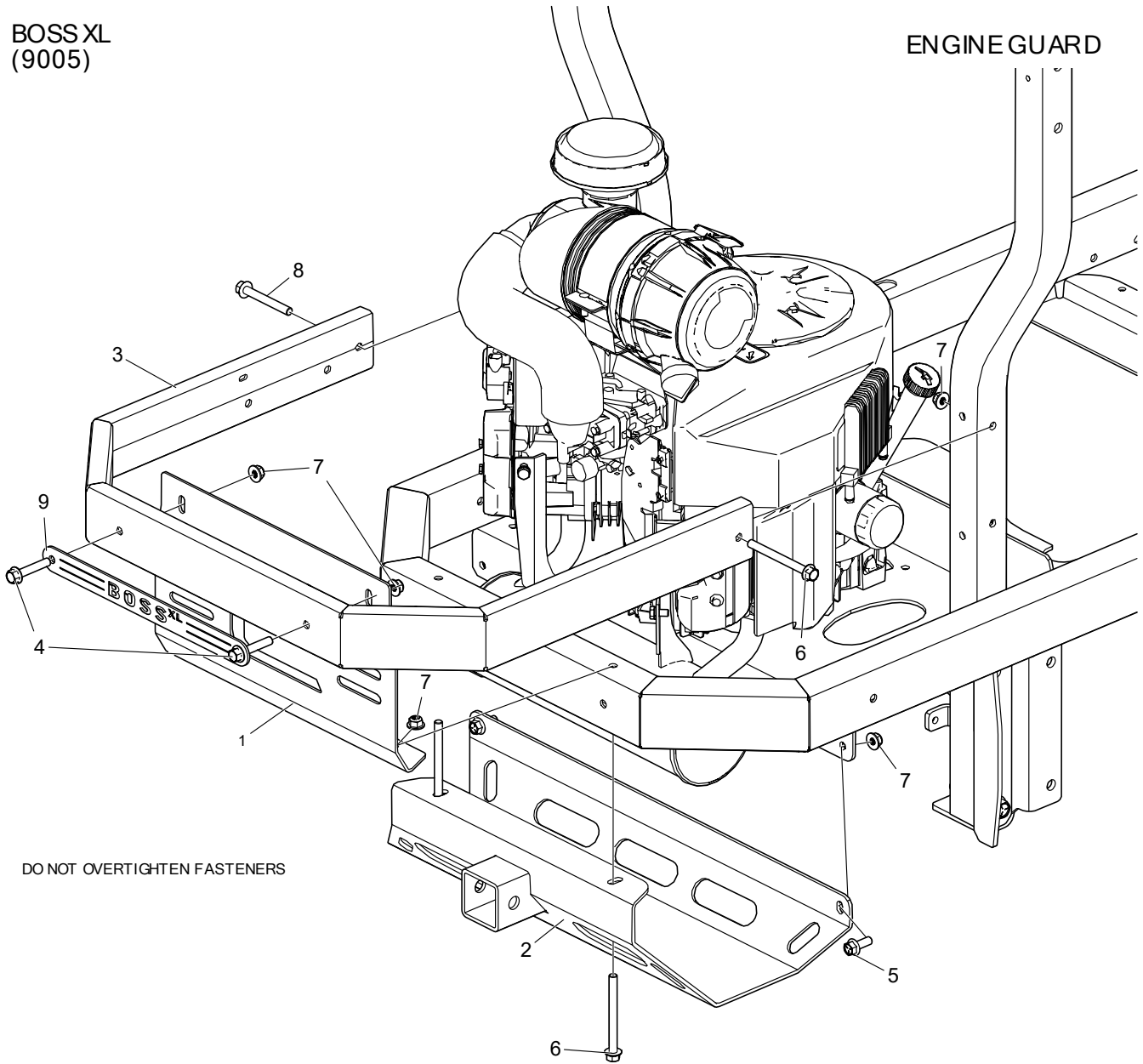

DO NOT OVERTIGHTEN FASTENERS

Item #	Qty	Part #	Description
1	1	724-160P	ENGINE GUARD
2	1	724-140W	WLDT, MUFFLER GUARD W/ HITCH
3	1	724-166W	WLDT, ENGINE WRAP
4	2	F-2126	FHCS, 3/8-16 X 2", YZ, GR5
5	2	F-2141	FHCS, 3/8-16 X 1", YZ, GR5
6	3	F-2142	FHCS, 3/8-16 X 4", YZ, GR5
7	8	F-2151	NUT, 3/8-16 NYLOC, FLANGED, YZ
8	1	F-2180	FHCS, 3/8-16 X 3", YZ, GR5
9	1	H-2912	PLACARD, BOSS XL

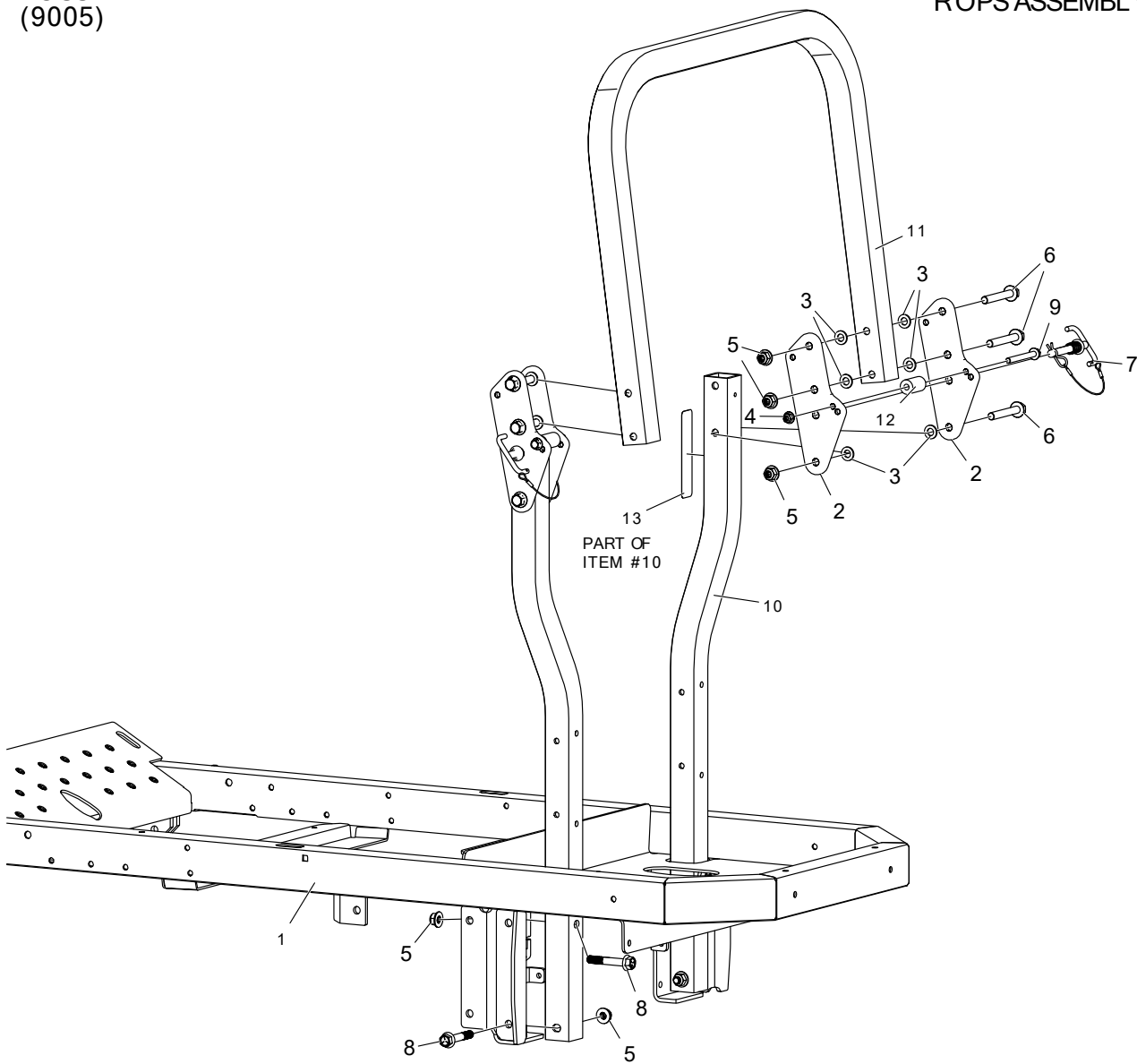

Item #	Qty	Part #	Description
1	1	724-006W	WLDT, FRAME
2	4	724-107P	HINGE PLATE, ROPS
3	12	F-1521	WASHER, 1/2" CUSTOM, YZ
4	2	F-2151	NUT, 3/8-16 NYLOC, FLANGED, YZ
5	10	F-2152	NUT, 1/2-13 NYLOC, FLANGED, YZ
6	6	F-2163	FHCS, 1/2-13 X 3-1/2", YZ, GR5
7	2	F-2208	PULL-PIN ASSEMBLY, T-HANDLE
8	4	F-2300	FHCS, 1/2-13 X 3", YZ, GR5
9	2	F-2303	FHCS, 3/8-16 x 3-1/2", YZ, GR5
10	2	629-977A	TUBE, POST - ROPS W/ DECAL
11	1	H-3105	TUBE, TOP LOOP - ROPS
12	2	H-3148	BUMPER, URETHANE
13	1	P-13480	DECAL, WARNING ROPS

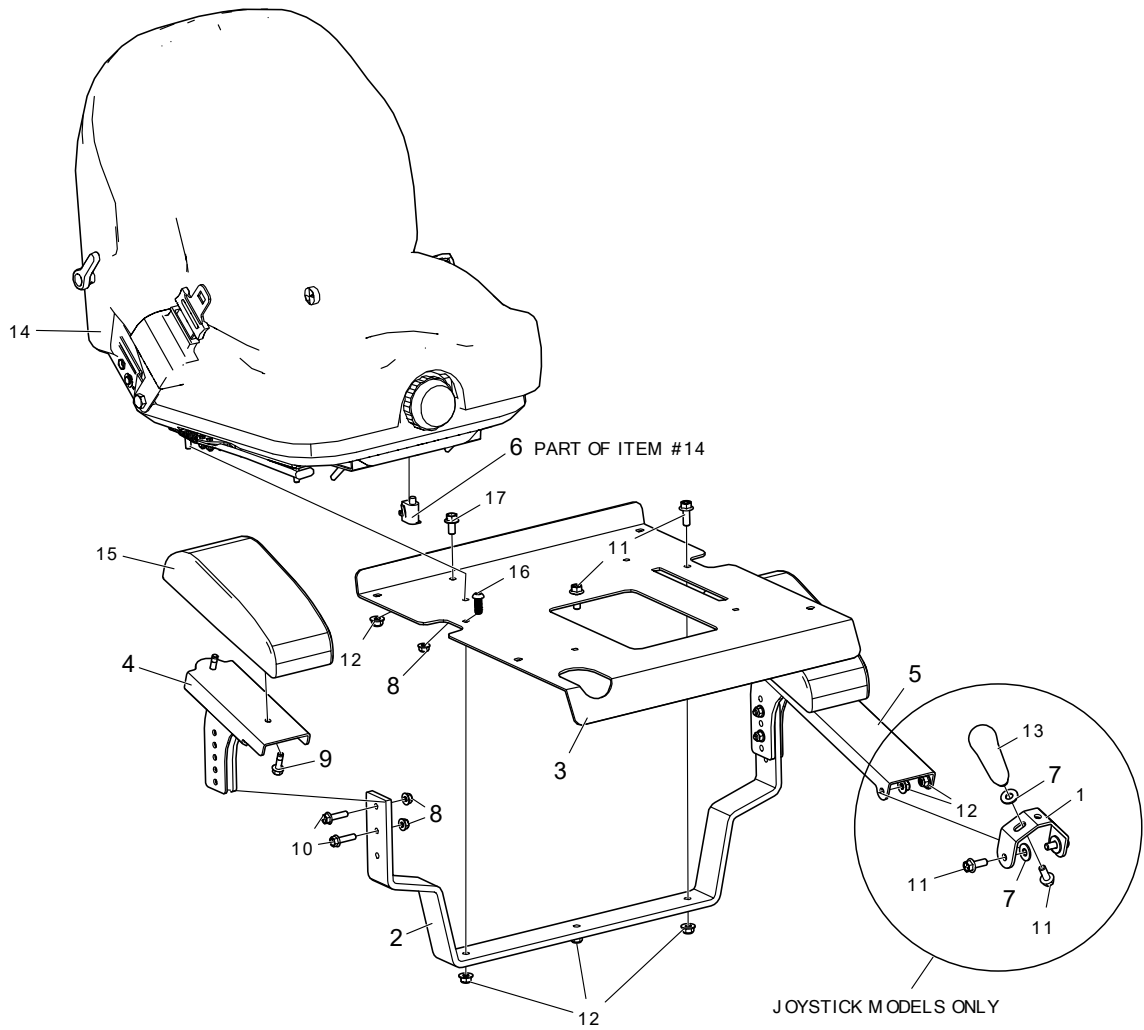

JOYSTICK MODELS ONLY

Item #	Qty	Part #	Description
1	1	724-075P	SECURITY GRIP MOUNT
2	1	724-105P	ARM REST MOUNT
3	1	724-116P	SEAT PAN
4	1	724-124W	WLDT, ARM REST MOUNT
5	1	724-125W	WLDT, ARM REST MOUNT, JS
-	1	724-124W	WLDT, ARM REST MOUNT, TS
6	1	E-6491	SEAT SWITCH
7	3	F-1009-03	WASHER, FLAT, 3/8, YZ
8	8	F-2063	NUT, 5/16-18, NYLOC, FLANGED, YZ
9	4	F-2121	FHCS, 5/16-18 X 1\", LOCK PATCH, YZ, GR5
10	4	F-2122	FHCS, 5/16-18 X 1-1/4\", YZ, GR5, FULL THD
11	5	F-2141	FHCS, 3/8-16 X 1\", YZ, GR5
12	6	F-2151	NUT, 3/8-16 NYLOC, FLANGED, YZ
13	1	H-2764	HANDLE, JOYSTICK
14	1	H-2788	SEAT, BOSS XL
-	1	H-2916	BACK COVER FOR SEAT H-2788
15	2	H-2799	PAD, ARM REST
16	1	F-2311	BUTTON, SHCS, 3/8-16 X 1"
17	1	F-2124	FHCS, 3/8-16 X 3/4\", YZ, GR5

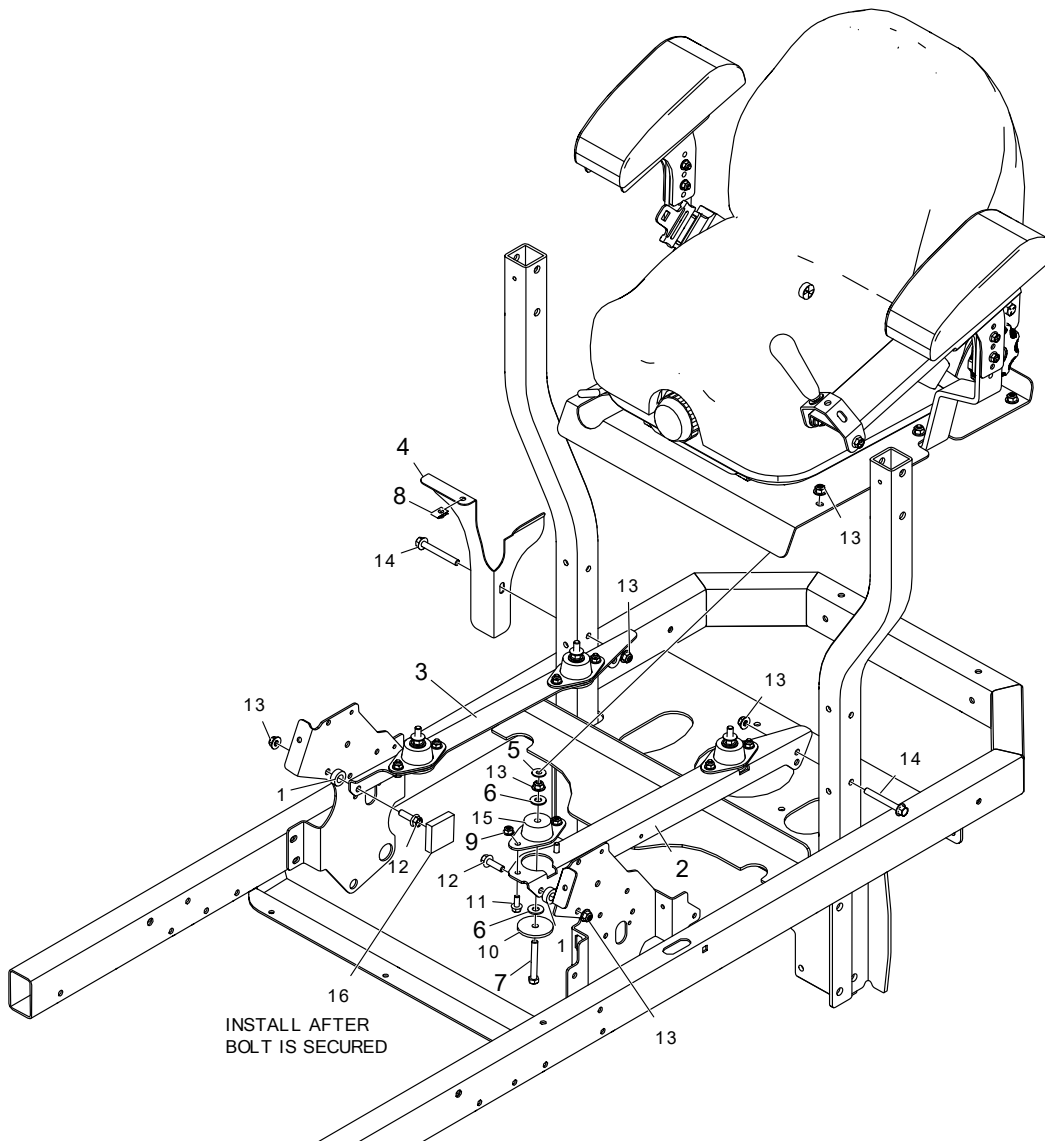

Item #	Qty	Part #	Description
1	2	660-038P	SPACER, 3/8" WIDE
2	1	724-043P	SEAT MOUNT ANGLE, LH
3	1	724-109P	SEAT MOUNT ANGLE, RH
4	1	724-153P	STIFFENER, FENDER CAP
5	4	F-1009-02	WASHER, FLAT
6	8	F-1009-03	WASHER, FLAT, 3/8, YZ
7	4	F-1542	HHCS, 3/8-16 X 2-3/4", YZ, GR5
8	1	F-1858	U-NUT, 1/4-20
9	8	F-2063	NUT, 5/16-18, NYLOC, FLANGED, YZ
10	4	F-2102	WASHER, 2.25 OD X .406 ID X 7GA, YZ
11	8	F-2120	FHCS, 5/16-18 X 3/4", YZ, GR5
12	2	F-2125	FHCS, 3/8-16 X 1-1/4", YZ, GR5
13	12	F-2151	NUT, 3/8-16 NYLOC, FLANGED, YZ
14	2	F-2180	FHCS, 3/8-16 x 3", YZ, GR5
15	4	H-2734	ISOLATOR, VIBRATION
16	1	H-2990	WEATHER-RESISTANT NEOPRENE FOAM (ADHESIVE) 1/2"

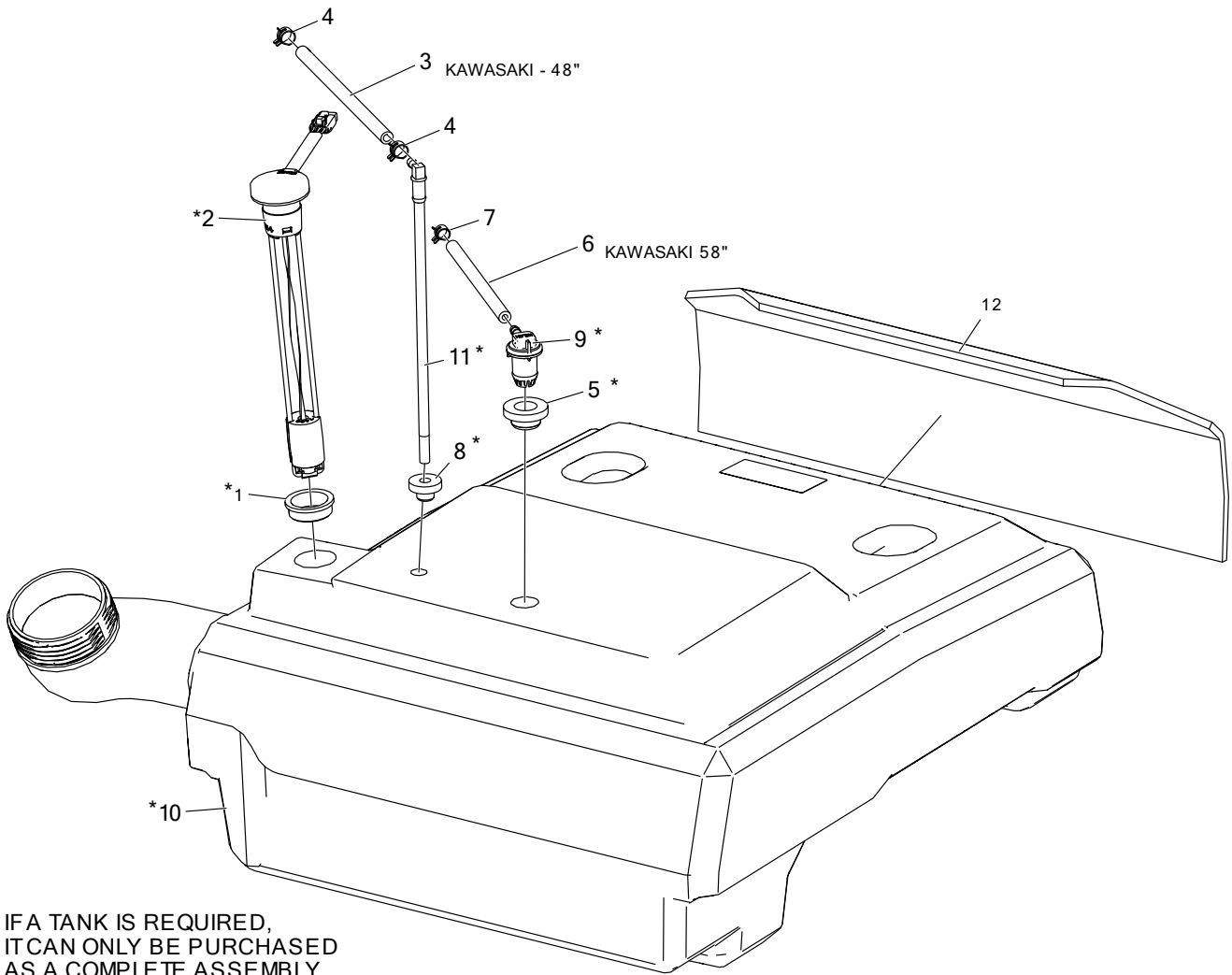

IF A TANK IS REQUIRED,  
IT CAN ONLY BE PURCHASED  
AS A COMPLETE ASSEMBLY  
{H-3144}

(PARTS MARKED '\*' ARE INCLUDED IN ASS'Y)

Item #	Qty	Part #	Description
1	1	E-6713	GROMMET, NITRILE
2	1	E-6715	ASSEMBLY, MULTI-LEVEL GAUGE
3	1	H-1648	FUEL LINE, 1/2" O.D., 1/4" I.D.
4	2	H-1687	1/2 O.D. HOSE SPRING CLAMP
5	1	H-2679	KELCH REMOTE VENT GROMMET
6	1	H-2697	HOSE, FUEL LINE .188 ID X .406 OD
7	1	H-2698	CLAMP, .406 OD FUEL LINE
8	1	H-2741	GROMMET, PICK UP TUBE
9	1	H-2831	KELCH REMOTE VENT ASSY
10	1	H-3144	ASSEMBLY, FUEL TANK, LG, BLK
11	1	H-3175	PICK UP TUBE
12	1	H-3185	HEAT SHIELD, ADHESIVE BACK

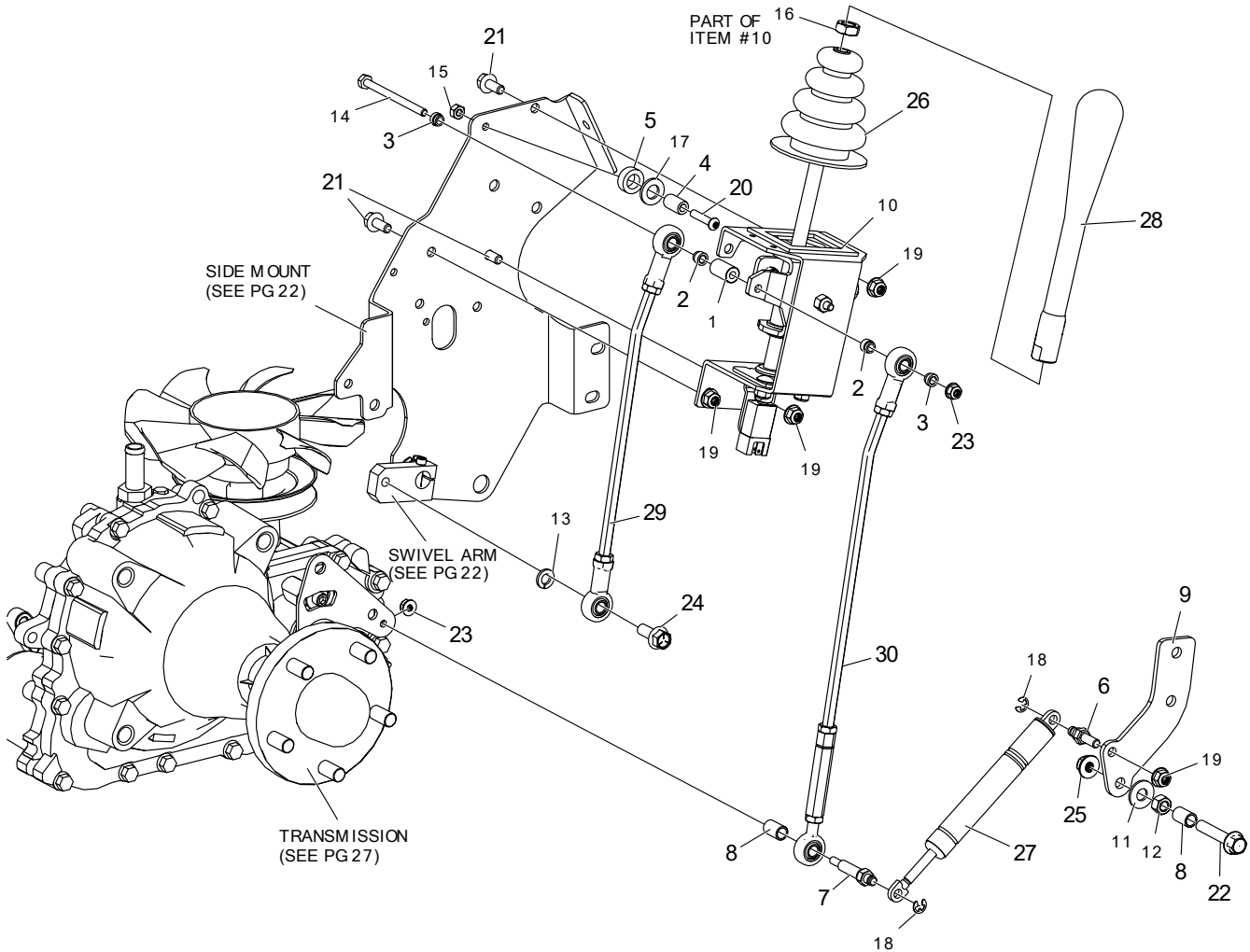

Item #	Qty	Part #	Description
1	1	625-100P	TUBE, PIVOT, JOYSTICK
2	2	625-107P	BUSHING, .375 ROD END
3	2	625-116P	BUSHING, .375 ROD END, SHORT
4	1	625-119P	PIN, PIVOT, JS, LONG
5	1	625-126P	SPACER, JOYSTICK PANEL
6	1	638-028P	DAMPER BOLT 5/16-18 X 3/4"
7	1	707-072P	STUD, LINKAGE MOUNT
8	2	707-073P	STAND-OFF, LINKAGE MOUNT
9	1	724-028P	DISCONNECT BRACKET
10	1	724-115A	JOYSTICK ASSEMBLY
11	1	F-1009-03	WASHER, FLAT, 3/8, YZ
12	1	F-1011-03	NUT, HEX, 3/8-16, YZ
13	1	F-1019-03	LOCKWASHER, HVY, 3/8, YZ
14	1	F-1020-01	CAPSCREW, 1/4-20 X 3-1/2", YZ, GR5
15	1	F-1158	NUT, CENTERLOCK, 1/4-20, YZ, GR5

Item #	Qty	Part #	Description
16	1	F-1462	JAM NUT, 1/2-20, RH, YZ
17	1	F-1521	WASHER, 1/2" CUSTOM, YZ
18	2	F-1610	RETAINING RING, EXTERNAL
19	4	F-2063	NUT, 5/16-18, NYLOC, FLANGED, YZ
20	1	F-2103	SHCS, BUTTON HD, 1/4-20 X 1-1/4", CZ
21	3	F-2120	FHCS, 5/16-18 X 3/4", YZ, GR5
22	1	F-2126	FHCS, 3/8-16 X 2", YZ, GR5
23	2	F-2132	NUT, 1/4-20 NYLOC, FLANGED, YZ
24	1	F-2141	FHCS, 3/8-16 X 1", YZ, GR5
25	1	F-2151	NUT, 3/8-16 NYLOC, FLANGED, YZ
26	1	H-1991	JOY STICK BOOT
27	1	H-2896	DAMPER-300 N-AVM
28	1	H-2964	HANDLE, JOYSTICK
29	1	H-3151	LINKAGE, INNER
30	1	H-3152	LINKAGE, OUTER

BOSS XL  
(9005)

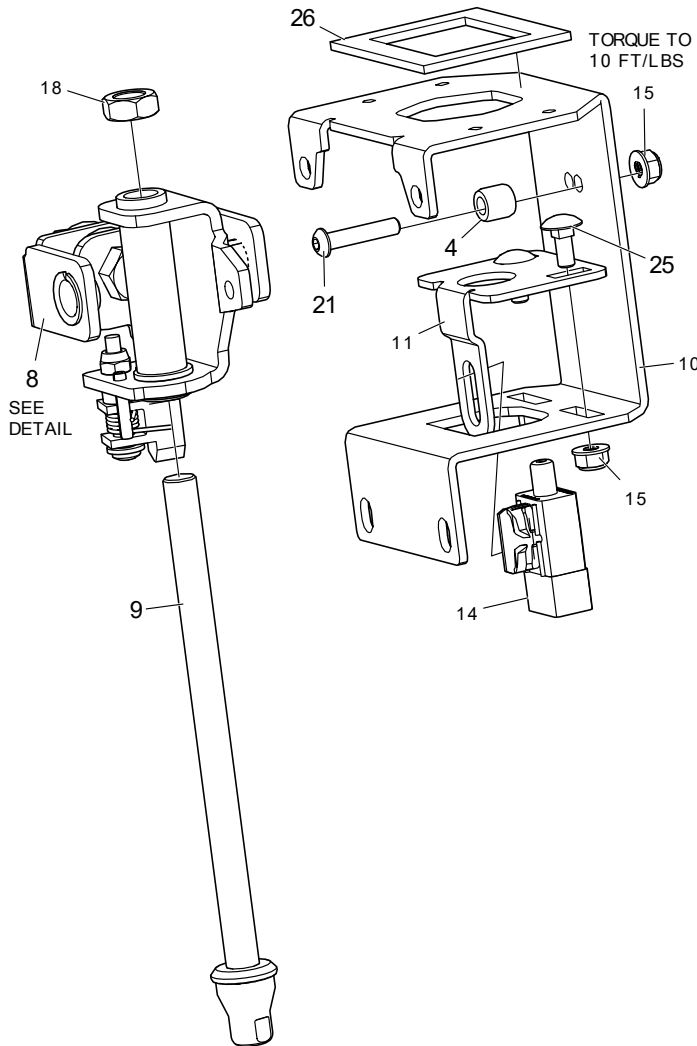

JOYSTICK ASSEMBLY  
{724-115A}

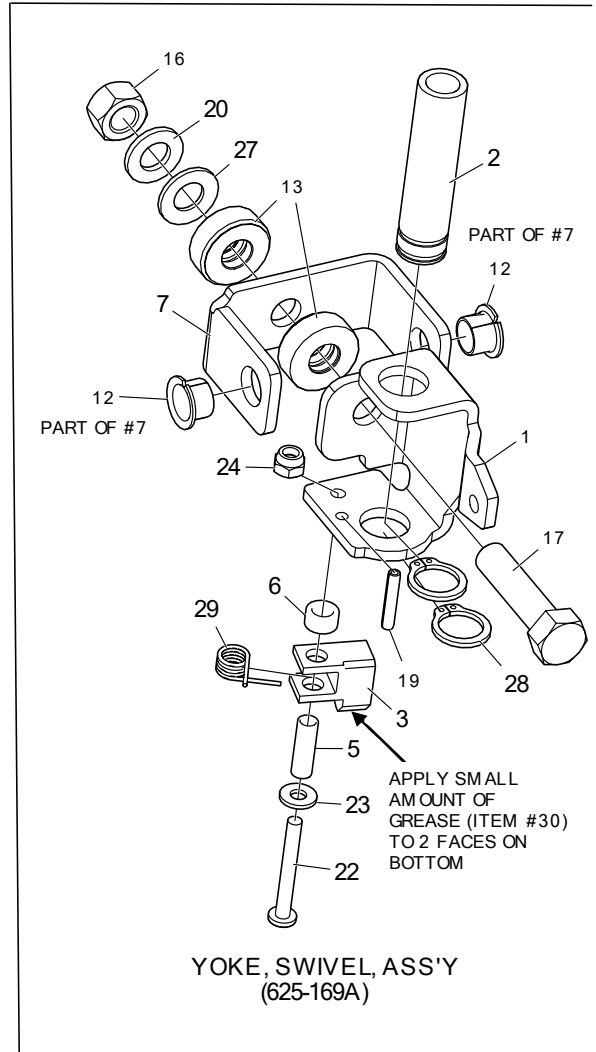

Item #	Qty	Part #	Description
1	1	625-096P	YOKE, SWIVEL, JOYSTICK
2	1	625-099P	TUBE, GUIDE, CONTROL ROD
3	1	625-103P	TAB, CAM DETENT
4	1	625-106P	PIN, PIVOT, JS
5	1	625-124P	TUBE-SPACER, DETENT CAM
6	1	625-125P	SPACER, CAM DETENT
7	1	625-128A	PIVOT ASSEMBLY
8	1	625-169A	YOKE, SWIVEL ASSEMBLY
9	1	709-169A	ROD ASSEMBLY, SHORT, 1/2"
10	1	724-113P	JOYSTICK HOUSING - DOUBLE SIDED
11	1	724-114P	JOYSTICK NEUTRAL PLATE
12	2	D-3784	BUSHING, DU 1/2 DIA X 3/8 WIDE
13	2	D-3931	THRUST BEARING
14	1	E-6692	PLUNGER SWITCH, RAIL MOUNT
15	3	F-2132	NUT, FLANGED, 1/4-20 w/NYLOC, YZ

Item #	Qty	Part #	Description
16	1	F-1005-05	NUT, 1/2-13, CENTERLOCK, YZ, GR5
17	1	F-1293	HHCS, 1/2-13 X 2", YZ, GR5
18	1	F-1462	JAM NUT, 1/2-20, RH, YZ
19	1	F-1503	PIN, SPIROL 3/16 DIA X 1 X .010 THK
20	1	F-1521	WASHER, 1/2" CUSTOM, YZ
21	1	F-2103	SHCS, BUTTON HD, 1/4-20 X 1", CZ
22	1	F-2135	SCREW, PANHEAD, PHILLIPS #12-24 X 1.75 CZ
23	1	F-2136	WASHER, FLAT, #12 PLAIN, CZ
24	1	F-2137	NUT, #12-24, NYLOCK
25	2	F-2155	BOLT, CARRIAGE, 1/4-20 X 5/8", YZ, GR5
26	1	H-1947	JOYSTICK GASKET
27	1	H-2704	SPRING, BELLEVILLE, .50 X 1 X .073
28	2	H-2705	RING, RETAINING, .75 EXT.
29	1	H-2710	SPRING, DETENT, JOYSTICK
30	1	C-6202	GREASE, CHEVRON RYKOTAC GREASE EP

# JOYSTICK ASSEMBLY MOUNTING & RELATED PARTS

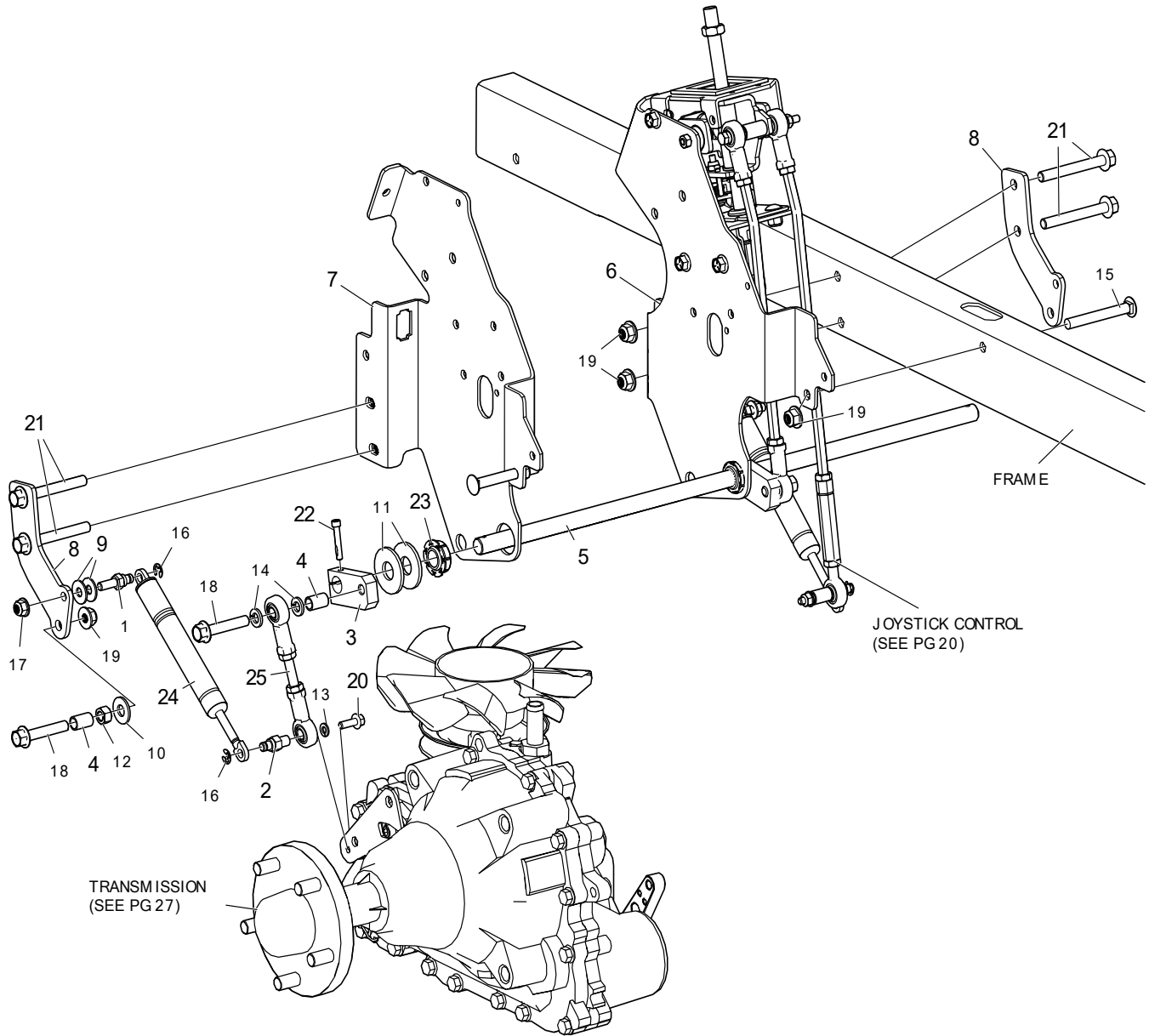

Item #	Qty	Part #	Description
1	1	638-028P	DAMPER BOLT 5/16-18 X 3/4"
2	1	663-051P	DAMPNER STUD, FEMALE
3	2	700-151P	ARM, SWIVEL
4	2	707-073P	STAND-OFF, LINKAGE MOUNT
5	1	709-229P	SHIFT ROD
6	1	724-017P	SIDE MOUNT CHANNEL, RH
7	1	724-018P	SIDE MOUNT CHANNEL, LH
8	2	724-028P	DISCONNECT BRACKET
9	2	F-1009-02	WASHER, FLAT
10	1	F-1009-03	WASHER, FLAT, 3/8
11	2	F-1009-06	WASHER, FLAT, 5/8
12	1	F-1011-03	NUT, HEX, 3/8-16, YZ
13	1	F-1019-01	WASHER, LOCK, 1/4, YZ

Item #	Qty	Part #	Description
14	2	F-1019-03	LOCKWASHER, HVY, 3/8, YZ
15	2	F-1024-01	BOLT, CARRIAGE, 3/8-16 X 3, CZ, GR5
16	2	F-1610	RETAINING RING, EXTERNAL
17	1	F-2063	NUT, 5/16-18, NYLOC, FLANGED, YZ
18	2	F-2126	FHCS, 3/8-16 X 2", YZ, GR5
19	7	F-2151	NUT, 3/8-16 NYLOC, FLANGED, YZ
20	1	F-2162	FHCS, 1/4-20 X 3/4", YZ, GR5
21	4	F-2180	FHCS, 3/8-16 x 3", YZ, GR5
22	2	F-2231	SHCS, 12-24 X 1-1/4", CZ, LOCK PATCH
23	2	H-2773	BEARING, FLANGED-SPHERICAL
24	1	H-2896	DAMPER-300 N-AVM
25	1	H-2926	LINKAGE, UPPER, JS



(RIGHT SIDE SHOWN)

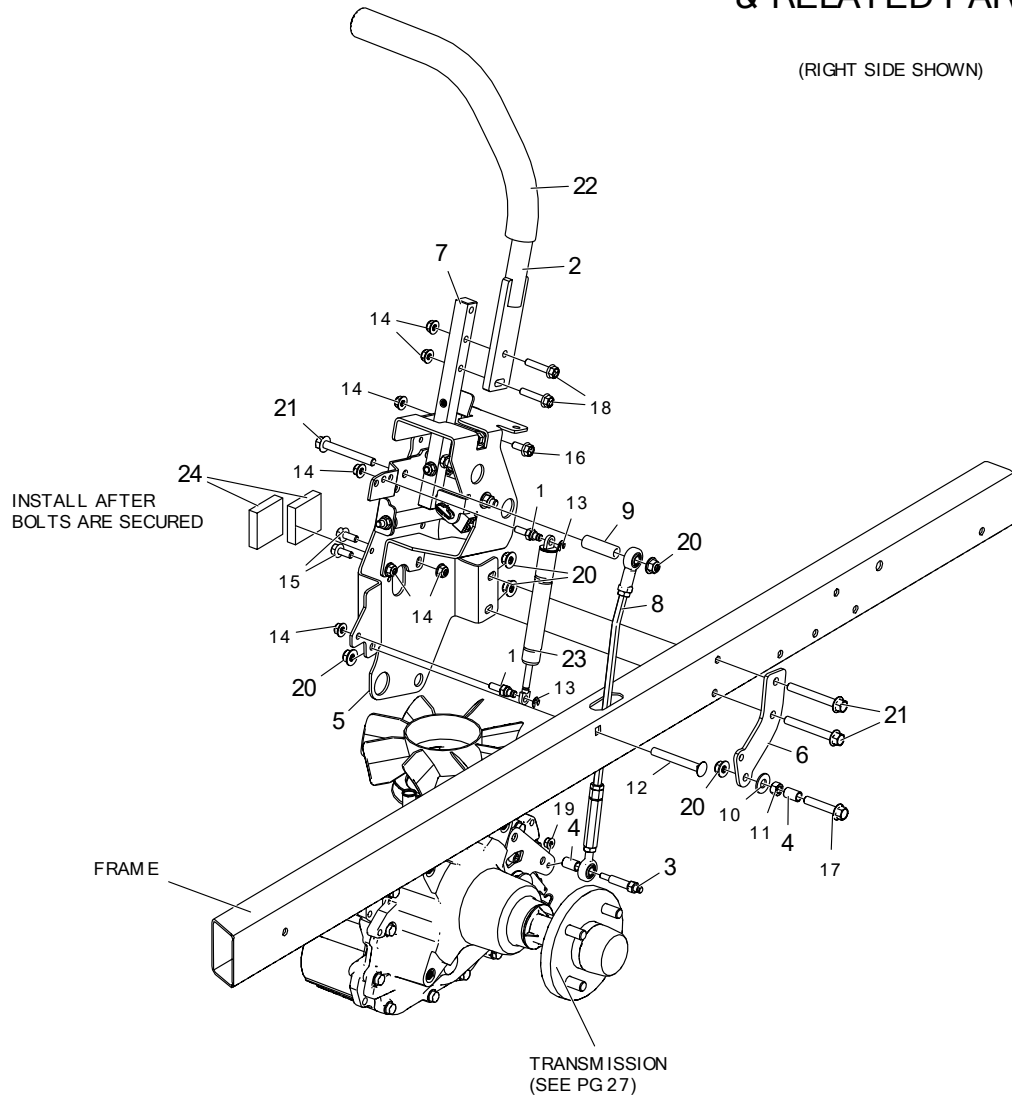

Item #	Qty	Part #	Description
1	2	638-028P	DAMPER BOLT 5/16-18 X 3/4"
2	1	659-375W	WLDT, DUAL LEVER
3	1	707-072P	STUD, LINKAGE MOUNT
4	2	707-073P	STAND-OFF, LINKAGE MOUNT
5	1	724-017P	SIDE MOUNT CHANNEL, RH
-	1	724-018P	SIDE MOUNT CHANNEL, LH
6	1	724-028P	DISCONNECT BRACKET
7	1	724-136A	ASSY, TS CONTROL, RH
-	1	724-137A	ASSY, TS CONTROL, LH
8	1	724-141P	LINKAGE, OUTER, TS
9	1	724-150P	SPACER, TWINSTICK LINKAGE
10	1	F-1009-03	WASHER, FLAT, 3/8, YZ
11	1	F-1011-03	NUT, HEX, 3/8-16, YZ

Item #	Qty	Part #	Description
12	1	F-1024-01	BOLT, CARRIAGE, 3/8-16 X 3, CZ, GR5
13	2	F-1610	RETAINING RING, EXTERNAL
14	7	F-2063	NUT, 5/16-18, NYLOC, FLANGED, YZ
15	2	F-2120	FHCS, 5/16-18 X 3/4", YZ, GR5, RH
-	2	F-2148	FHCS, 5/16-18 X 1", YZ, GR5, LH
16	1	F-2120	FHCS, 5/16-18 X 3/4", YZ, GR5
17	1	F-2126	FHCS, 3/8-16 X 2", YZ, GR5
18	2	F-2129	FHCS, 5/16-18 X 1-1/2", YZ, GR5
19	1	F-2132	NUT, 1/4-20 NYLOC, FLANGED, YZ
20	5	F-2151	NUT, 3/8-16 NYLOC, FLANGED, YZ
21	3	F-2180	FHCS, 3/8-16 x 3", YZ, GR5
22	1	H-2739	GRIP, 15", CLOSED END
23	1	H-2896	DAMPER-300 N-AVM
24	2	H-2990	WEATHER-RESISTANT NEOPRENE FOAM (ADHESIVE) 1/2"

{724-136A - RIGHT SIDE}  
{724-137A - LEFT SIDE}

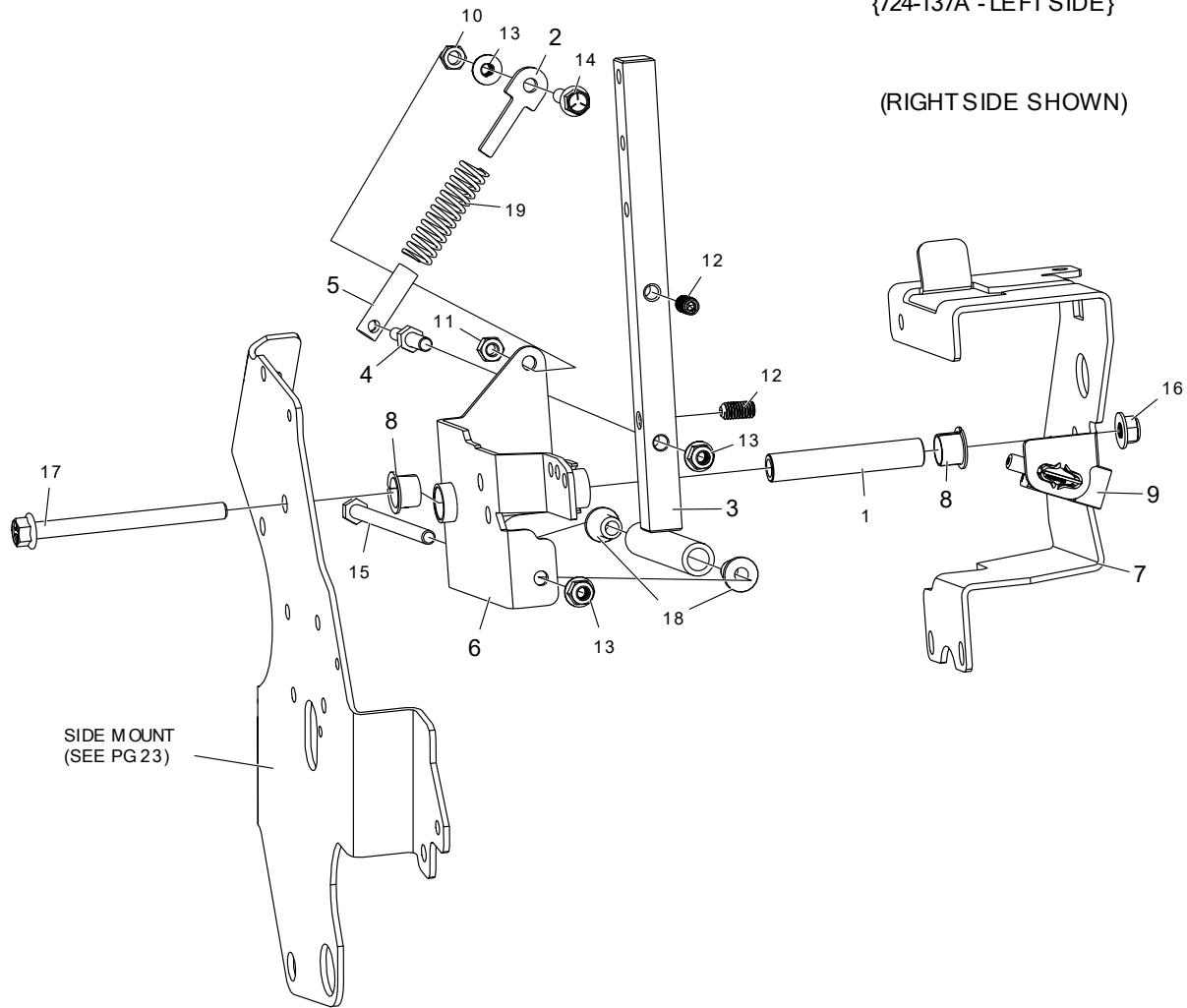

Item #	Qty	Part #	Description
1	1	714-074P	PIN, PIVOT, TWIN LEVER
2	1	721-006P	SPRING GUIDE, TS
3	1	721-090W	WLDT, HANDLE BASE
4	1	721-093P	PIN, SPRING OVER-CENTER
5	1	721-094P	SPRING GUIDE, TS OVER-CENTER
6	1	724-130W	WLDT, TWIN STICK PIVOT, RH
-	1	724-132W	WLDT, TWIN STICK PIVOT, LH
7	1	724-134P	HOUSING, TWIN STICK, RH
-	1	724-135P	HOUSING, TWIN STICK, LH
8	2	D-3730	BUSHING, DU 5/8 DIA X 1/2 LG
9	1	E-6692	PLUNGER SWITCH, RAIL MOUNT
10	1	F-1011-02	NUT, HEX 5/16-18
11	1	F-1125	NUT, CENTERLOCK, 5/16-18, YZ, GR5
12	2	F-1903	SETSCREW, 3/8-16 X 3/4" W/ NYLON
13	3	F-2063	NUT, 5/16-18, NYLOC, FLANGED, YZ
14	1	F-2122	FHCS, 5/16-18 X 1-1/4", YZ, GR5, FULL THD
15	1	F-2145	HHCS, 5/16-18 X 6", YZ, GR8
16	1	F-2151	NUT, 3/8-16 NYLOC, FLANGED, YZ
17	1	F-2160	FHCS, 3/8-16 X 4-1/2", YZ, GR5
18	2	H-3009	BUSHING, 0.313, NYLON, FLANGED
19	1	H-3079	SPRING, TS OVER CENTER

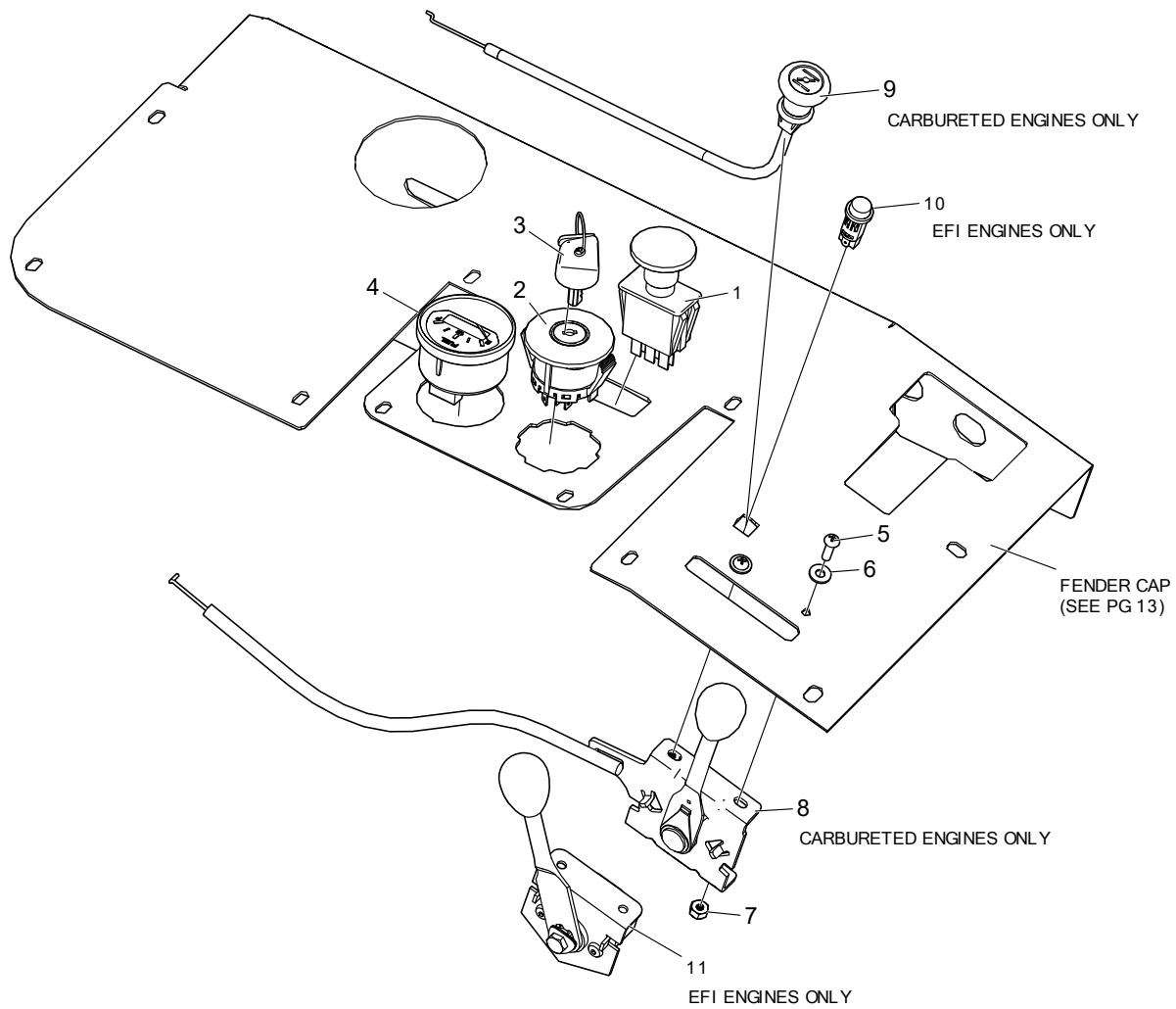

Item #	Qty	Part #	Description
1	1	E-6403	PTO SWITCH
2	1	E-6717	IGNITION SWITCH, 4-POSITION W/ PLASTIC KEYWAY
3	1	E-6718	KEY ASSEMBLY
4	1	E-6716	HOUR METER
5	2	F-1022-26	MACHINE SCREW, RND, 10-32 X 5/8, SLOTTED, CZ
6	2	F-1071	WASHER, FLAT #10, ZINC PLATED
7	2	F-1448	LOCKNUT, 10-32 NYLOC YELLOW PLTD
8	1	H-3164	THROTTLE CABLE (54.50"), KAWASAKI
9	1	H-3166	CHOKE CABLE (50.00")
10	1	E-6314	INCANDESCENT LIGHT, 12V, RED
11	1	E-6784	EFI THROTTLE LEVER ASSEMBLY

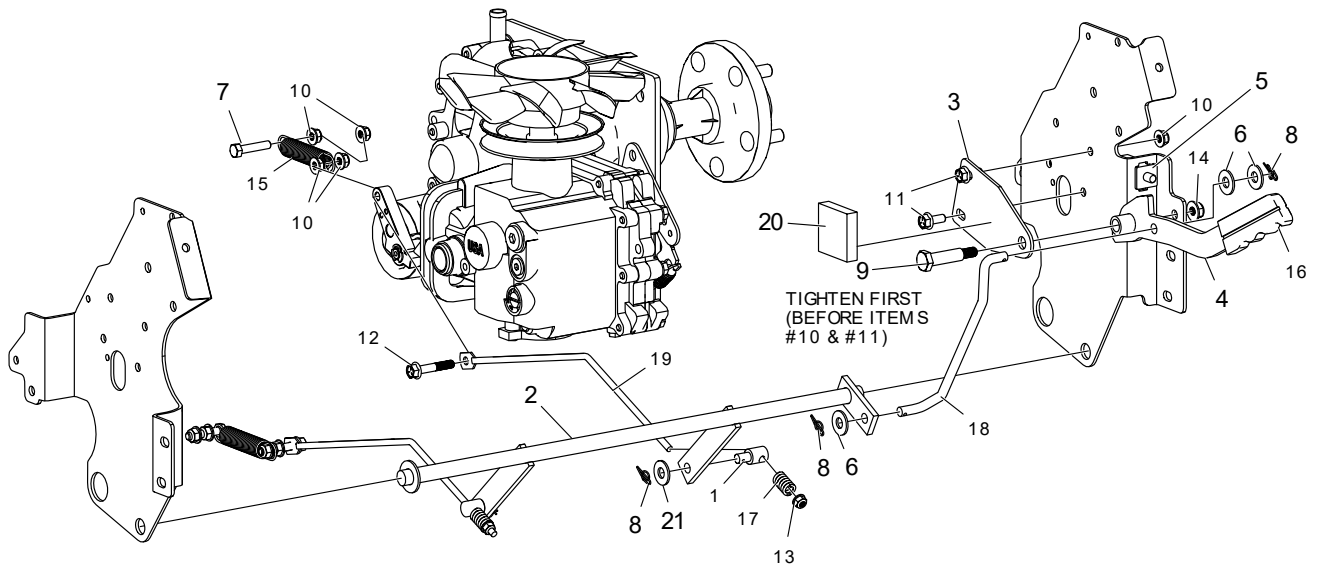

Item #	Qty	Part #	Description
1	2	709-221P	BRAKE LINK ANCHOR
2	1	724-034W	WLDT, BRAKE ROD
3	1	724-040P	BRAKE HANDLE MOUNT PLATE
4	1	724-054W	WLDT, BRAKE HANDLE
5	1	E-6474	SWITCH, SNAP MOUNT
6	3	F-1009-03	WASHER, FLAT, 3/8, YZ
7	2	F-1015-17	HHCS, 5/16-18 X 1-1/2", YZ, GR5
8	4	F-1492	RUE RING, 5/16
9	1	F-2061	SHOULDER BOLT, .50 DIA X 1.625, HEX HEAD
10	10	F-2063	NUT, 5/16-18, NYLOC, FLANGED, YZ
11	2	F-2148	FHCS, 5/16-18 X 1", YZ, GR5
12	2	F-2123	FHCS, 5/16-18 X 1-3/4", YZ, GR5
13	2	F-2132	NUT, 1/4-20 NYLOC, FLANGED, YZ
14	1	F-2151	NUT, 3/8-16 NYLOC, FLANGED, YZ
15	2	H-1635	SPRING, EXT, 3/4" OD X 4" OAL
16	1	H-1926	1/4" X 1" HANDLE GRIP
17	2	H-2786	SPRING, COMP, 0.562 X 0.88 HGT
18	1	H-3101	LINK ROD, BRAKE HANDLE
19	2	H-3136	BRAKE LINK ROD
20	1	H-2990	WEATHER-RESISTANT NEOPRENE FOAM (ADHESIVE) 1/2"
21	2	F-2083	3/8" WASHER, FENDER

# TRANSMISSION & RELATED PARTS

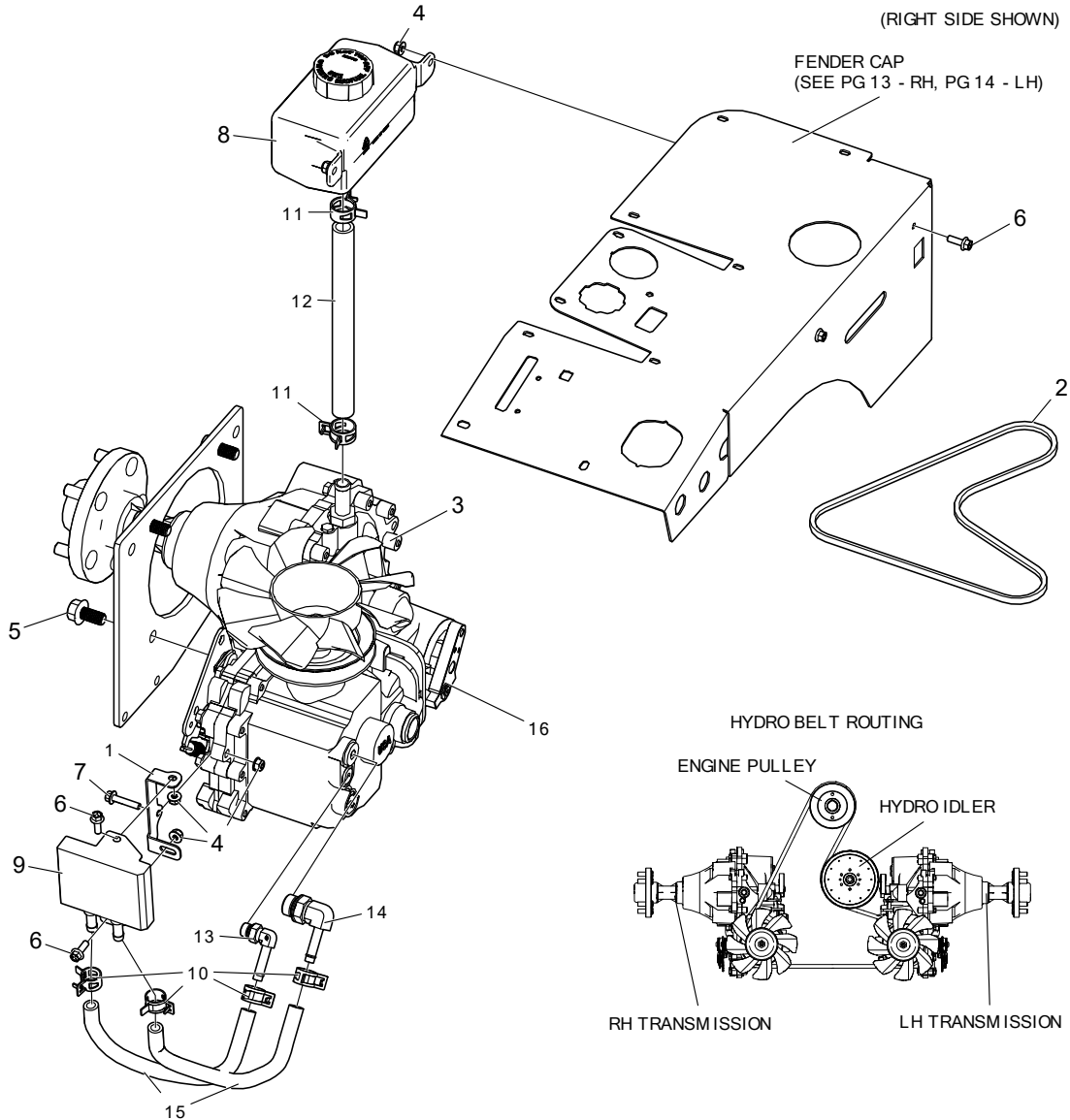

Item #	Qty	Part #	Description
1	1	730-023P	OIL COOLER MOUNT BRACKET, RH
-	1	730-024P	OIL COOLER MOUNT BRACKET, LH
2	1	D-3900	V-BELT, B-71 KEVLAR
3	1	D-4054-01	TRANSAXLE, ZT5400, RH, RTN, 8 BLADE FAN
-	1	D-4054-02	TRANSAXLE, ZT5400, LH, RTN, 8 BLADE FAN
4	5	F-2132	NUT, 1/4-20 NYLOC, FLANGED, YZ
5	4	F-2143	FHCS, 1/2-13 X 1", YZ, GR5
6	4	F-2162	FHCS, 1/4-20 X 3/4", YZ, GR5
7	1	F-2182	FHCS, 1/4-20 X 1-1/4", YZ, GR5
8	1	H-2735	TANK, HYDRO EXPANSION
9	1	H-2780	COOLER, OIL, STACKED PLATE, 3" X 4"
10	4	H-3088	HOSE CLAMP, 3/4" HOSE O.D.
11	2	H-3090	HOSE CLAMP, 1" HOSE O.D.
12	1	H-3161	HOSE, 5/8" ID x 9-3/4", HI-TEMP
13	1	H-3168	FITTING, 9/16"-18 THD, 90° EL, w/NUT, WASHER & O-RING
14	1	H-3169	FITTING, 7/8"-14 THD, 90° EL, w/NUT, WASHER & O-RING
15	2	H-3170	HOSE, 3/8" ID x 11", HI-TEMP
16	1	H-3208	OIL FILTER, FITS ZT-5400

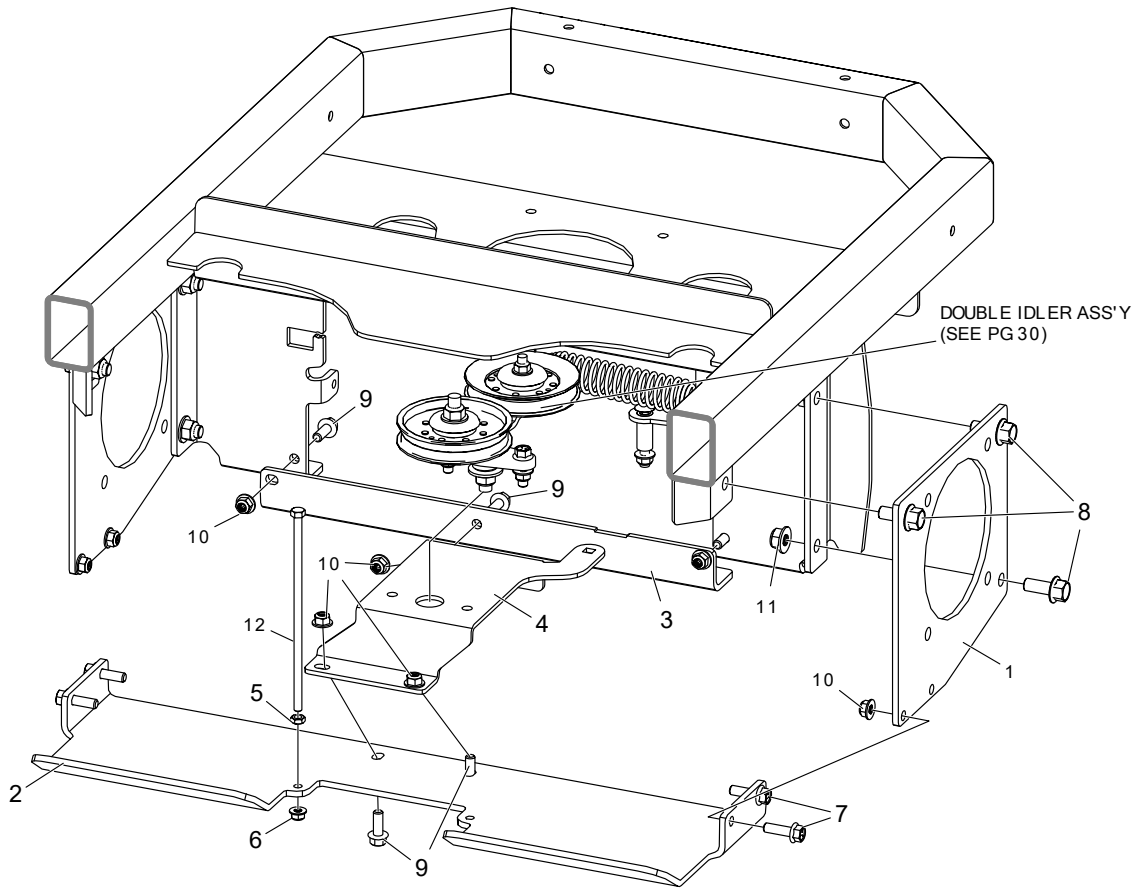

Item #	Qty	Part #	Description
1	2	724-015P	HYDRO MOUNT PLATE
2	1	724-016P	HYDRO MOUNT BRACE
3	1	724-046P	DOUBLE IDLER TENSION ARM
4	1	724-048P	DOUBLE IDLER MOUNTING BRACKET
5	1	F-1125	NUT, HEX 5/16-18, CENTERLOCKING
6	1	F-2063	NUT, 5/16-18, NYLOC, FLANGED, YZ
7	4	F-2125	FHCS, 3/8-16 X 1-1/4", YZ, GR5
8	6	F-2127	FHCS, 1/2-13 X 1-1/4", YZ, GR5
9	5	F-2141	FHCS, 3/8-16 X 1", YZ, GR5
10	9	F-2151	NUT, 3/8-16 NYLOC, FLANGED, YZ
11	6	F-2152	NUT, 1/2-13 NYLOC, FLANGED, YZ
12	1	F-2156	HHCS, 5/16-18 X 8-1/2", YZ, GR5

(LOOKING AT BOTTOM)

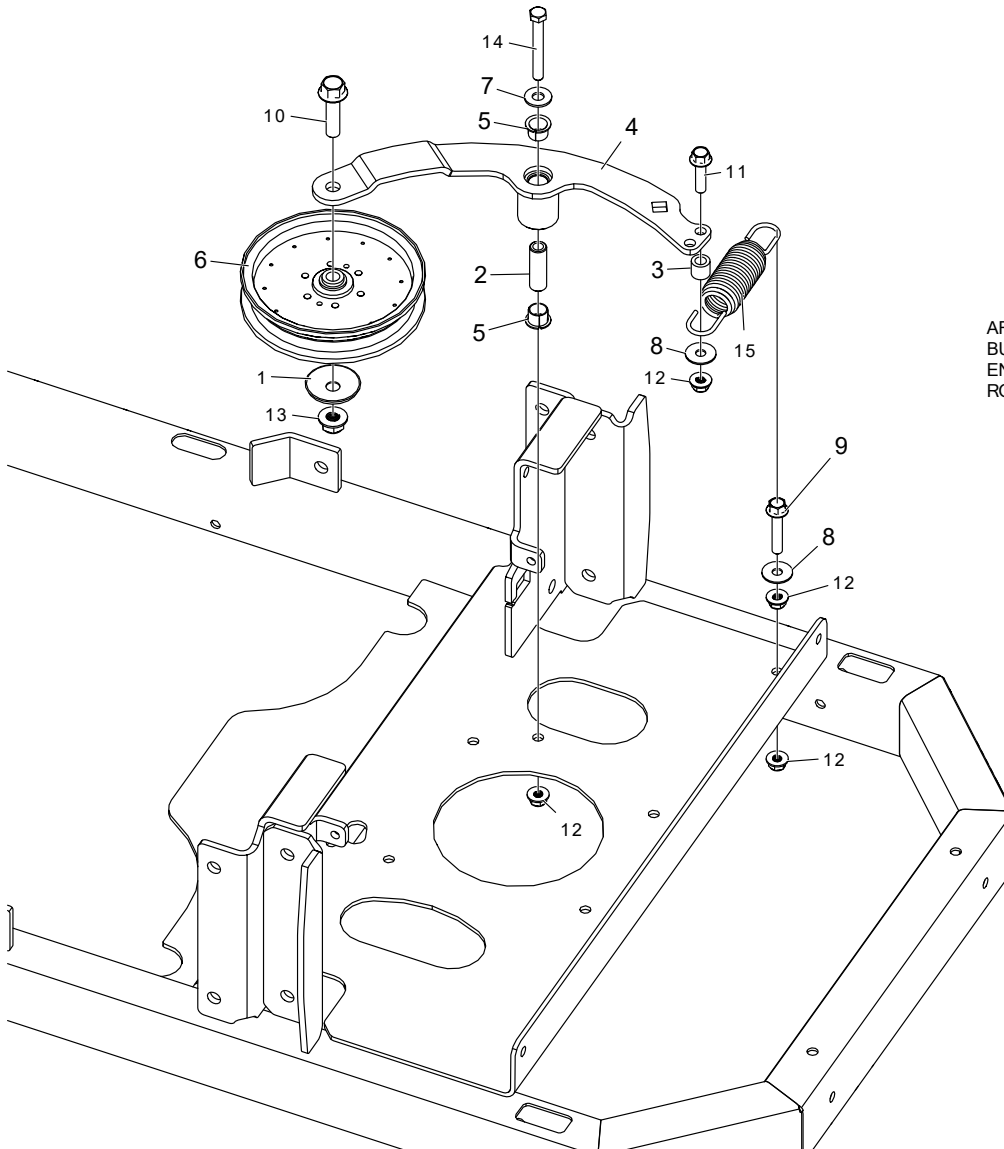

AFTER PRESSING IN  
BUSHINGS (ITEM #5),  
ENSURE PIN (ITEM #2)  
ROTATES FREELY

Item #	Qty	Part #	Description
1	1	620-201P	WASHER, BEARING CAP
2	1	709-077P	MOUNTING PIN
3	1	709-123P	SPACER, BELT TENSION
4	1	724-059W	WLDT, HYDRO IDLER ARM
5	2	D-3730	BUSHING, DU 5/8 DIA X 1/2 LG
6	1	D-3903	PULLEY, FLAT IDLER, 6" (NTN)
7	1	F-1009-03	WASHER, FLAT, 3/8, YZ
8	2	F-2083	WASHER, FENDER, 3/8", YZ
9	1	F-2126	FHCS, 3/8-16 X 2", YZ, GR5
10	1	F-2128	FHCS, 1/2-13 X 2", YZ, GR5
11	1	F-2147	FHCS, 3/8-16 X 1-1/2", YZ, GR5
12	4	F-2151	NUT, 3/8-16 NYLOC, FLANGED, YZ
13	1	F-2152	NUT, 1/2-13 NYLOC, FLANGED, YZ
14	1	F-2207	HHCS, 3/8-16 X 3", YZ, GR8
15	1	H-2995	SPRING, TAPPERED, LONG HOOK

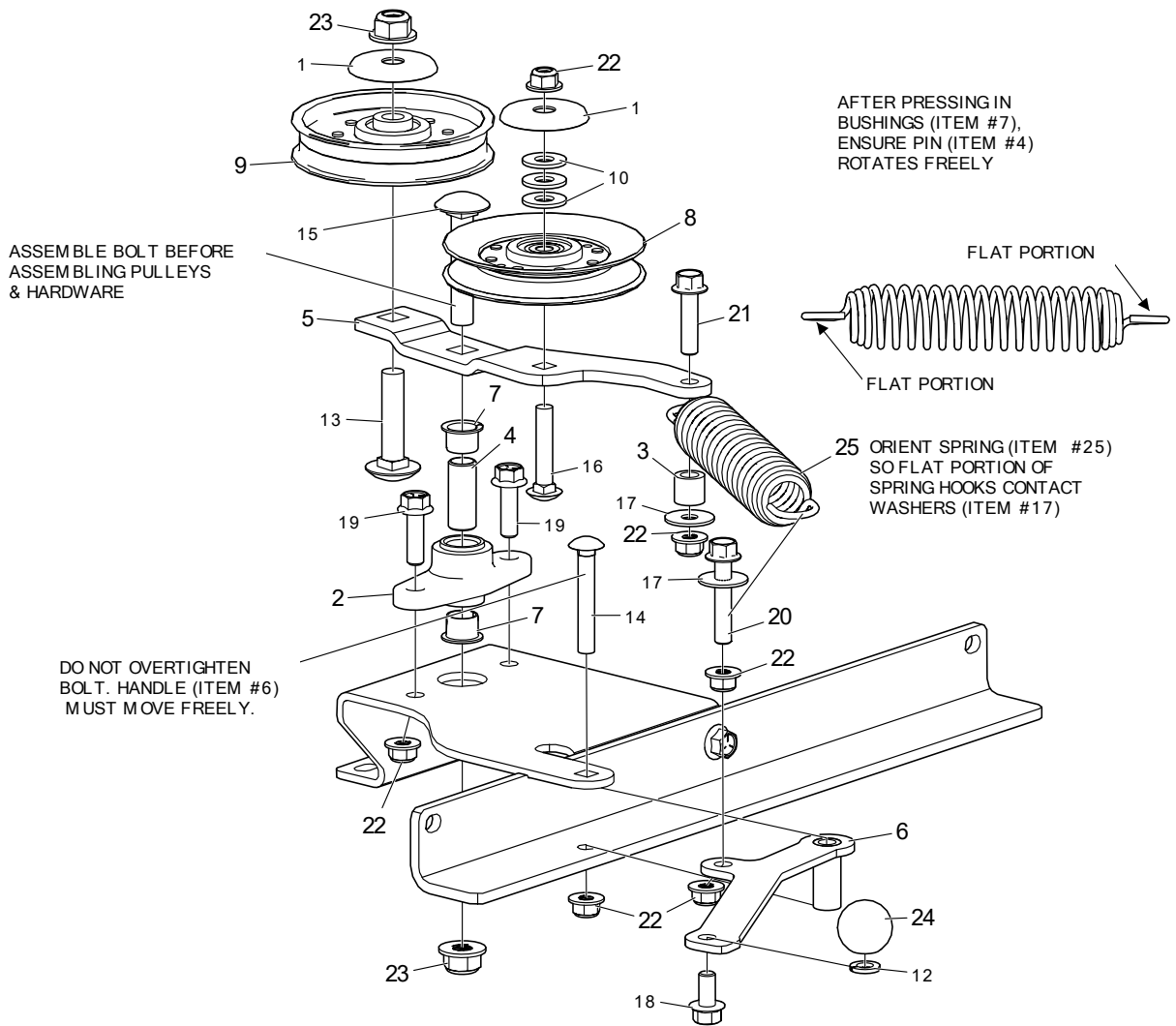

Item #	Qty	Part #	Description
1	2	620-201P	WASHER, BEARING CAP
2	1	660-039P	MOUNT, DOUBLE IDLER
3	1	709-123P	SPACER, BELT TENSION
4	1	722-031P	MOUNTING PIN
5	1	724-049P	DOUBLE IDLER ARM
6	1	724-065W	WLDT, DBL IDLER RELEASE HANDLE
7	2	D-3730	BUSHING, DU 5/8 DIA X 1/2 LG
8	1	D-3923	PULLEY, V-IDLER, 4.59OD, AB, NTN
9	1	D-3924	PULLEY, FLAT IDLER, 4.25 OD, NTN, DBL INSERT
10	3	F-1009-03	WASHER, FLAT, 3/8, YZ
12	1	F-1019-03	LOCKWASHER, HVY, 3/8, YZ
13	1	F-1822	BOLT, CARRIAGE, 1/2-13 X 2-1/4", YZ, GR5

Item #	Qty	Part #	Description
14	1	F-1865	CARRIAGE BOLT, 3/8-16 X 2-1/2", YZ, GR5
15	1	F-1927	CARRIAGE BOLT, 1/2-13 X 2-3/4"
16	1	F-1976	BOLT, CARRIAGE, 3/8-16 X 2", YZ, GR5
17	2	F-2083	WASHER, FENDER, 3/8", YZ
18	1	F-2124	FHCS, 3/8-16 X 3/4", YZ, GR5
19	2	F-2125	FHCS, 3/8-16 X 1-1/4", YZ, GR5
20	1	F-2126	FHCS, 3/8-16 X 2", YZ, GR5
21	1	F-2147	FHCS, 3/8-16 X 1-1/2", YZ, GR5
22	7	F-2151	NUT, 3/8-16 NYLOC, FLANGED, YZ
23	2	F-2152	NUT, 1/2-13 NYLOC, FLANGED, YZ
24	1	H-2405	BALL, 1-1/4"
25	1	H-2619	SPRING, 5 X 1-1/2, TAPERED ENDS



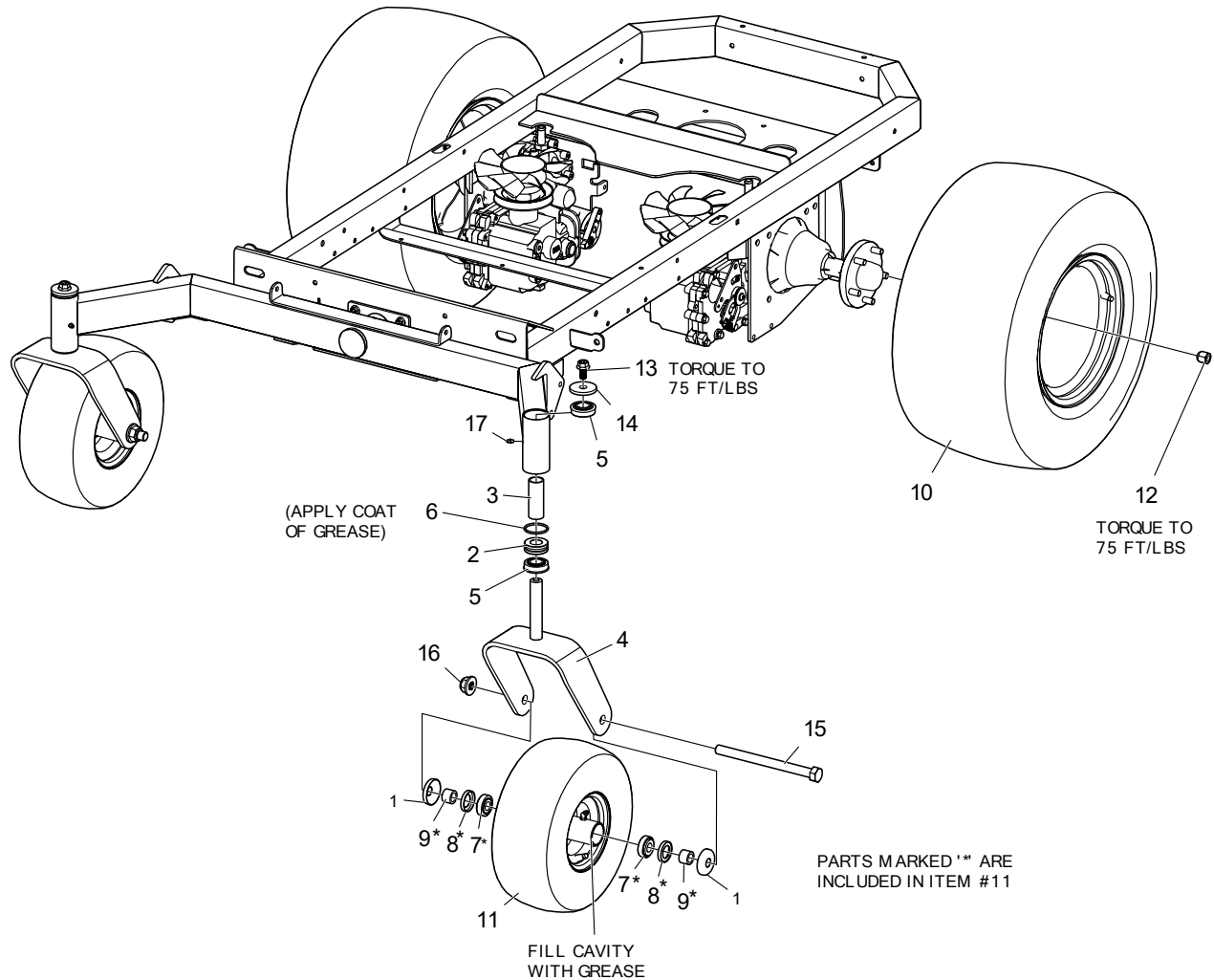

Item #	Qty	Part #	Description
1	4	663-221P	CAP, WHEEL BEARING
2	2	720-047P	DRAG RING - SERIAL RANGE: 21286001 - 21318999
-	2	720-135P	DRAG RING, (FOR 5MM O-RING) - SERIAL RANGE: 21319001 -
3	2	721-021P	SPACER, CASTER
4	2	724-112W	WLDT, CASTER YOKE
5	4	D-2008-02	BEARING, SPD, SF-16-32
6	2	D-3969	O-RING, 70 DURO NITRILE - SERIAL RANGE: 21286001 - 21318999
-	2	D-4190	O-RING, 5MM X 44MM I.D. - SERIAL RANGE: 21319001 -
7	4	D-4021-4	TAPER ROLLER BEARING
8	4	D-4021-5	GREASE SEAL
9	4	D-4021-6	SPACER
10	2	D-4187	TIRE & WHEEL ASSEMBLY 5 BOLT 26X12.00-12, FLAT BLACK
-	2	D-4189	TIRE ONLY, 26X12.00-12
11	2	D-4055	TIRE ASSEMBLY, FLAT BLACK, SMOOTH, 15X6.00
12	10	F-1499	LUG NUT, 1/2-20, YZ
13	2	F-2143	FHCS, 1/2-13 X 1", YZ, GR5
14	2	F-2179	WASHER, CASTER, .531 ID X 2.25 OD X .25THK, YZ
15	2	F-2194	HHCS, 3/4-10 X 9-1/2", YZ, GR5
16	2	F-2195	NUT, FLANGE NYLOC, YZ
17	2	H-1056	1/4" GREASE FITTING

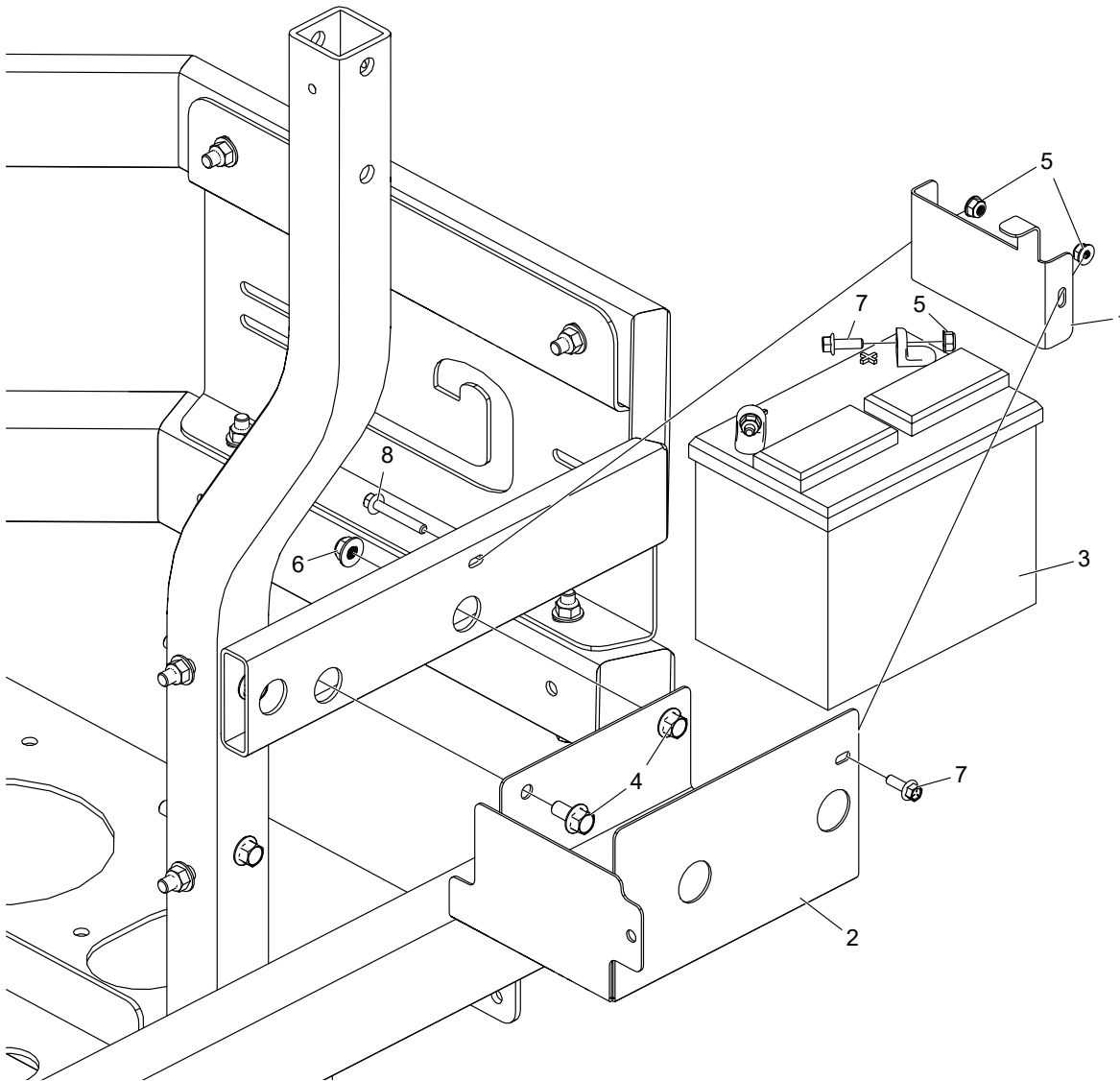

Item #	Qty	Part #	Description
1	1	724-147P	BACK PLATE, BATTERY BOX
2	1	724-148P	BATTERY BOX
3	1	----	12 VOLT BATTERY YSP 40, 350 CCA
4	2	F-2124	FHCS, 3/8-16 X 3/4", YZ, GR5
5	4	F-2132	NUT, 1/4-20 NYLOC, FLANGED, YZ
6	2	F-2151	NUT, 3/8-16 NYLOC, FLANGED, YZ
7	3	F-2162	FHCS, 1/4-20 X 3/4", YZ, GR5
8	1	F-2216	FHCS, 1/4-20 X 1-3/4", YZ, GR5

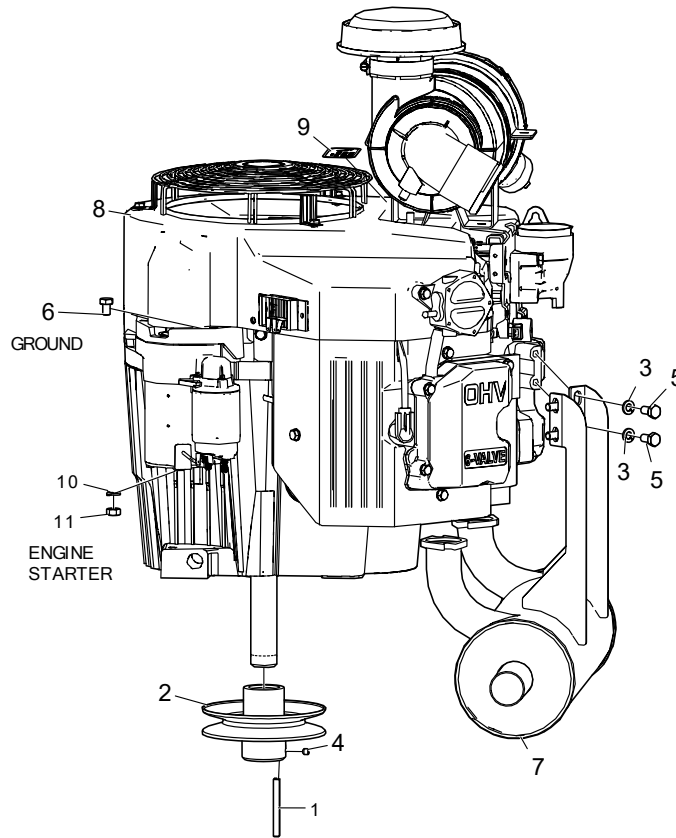

**KAWASAKI**

31 HP - FX921V  
 35 HP - FX1000V  
 38.5 HP - FX1000V - EFI

(USE THROTTLE CABLE H-3164 & CHOKE CABLE H-3166)  
 (USE THROTTLE LEVER ASSEMBLY E-6784 - EFI ONLY)

Item #	Qty	Part #	Description
1	1	724-154P	KEY STOCK, 1/4 X 1/4 X 2-1/2
2	1	D-4002	MOTOR PULLEY, 5.00" DIA, W/ 1-1/8" SHAFT
3	4	F-1019-02	LOCKWASHER
4	1	F-1228	SET SCREW, SOCKET, 1/4-20 X 1/4", W/ NYLOC
5	4	F-1834	HHCS, M8 X 16MM, YZ, GR.8.8
6	1	F-2243	HHCS, M8-1.25 X 12, YZ, GR8
7	1	H-3069	MUFFLER, 5", KAWASAKI, FX100V
8	1	M-5428	ENGINE, KAWASAKI, 31 HP, FX921V
-	1	M-5429	ENGINE, KAWASAKI, 35 HP, FX1000V
-	1	M-5438	ENGINE, KAWASAKI, 38.5 HP, FX1000V, EFI
9	1	P-10077-11	DECAL, "PERIODIACALLY CLEAN"
10	1	F-2258	WASHER, LOCK, M8, SS
11	1	F-2257	NUT, M8-1.25, SS

(LOOKING AT BOTTOM)

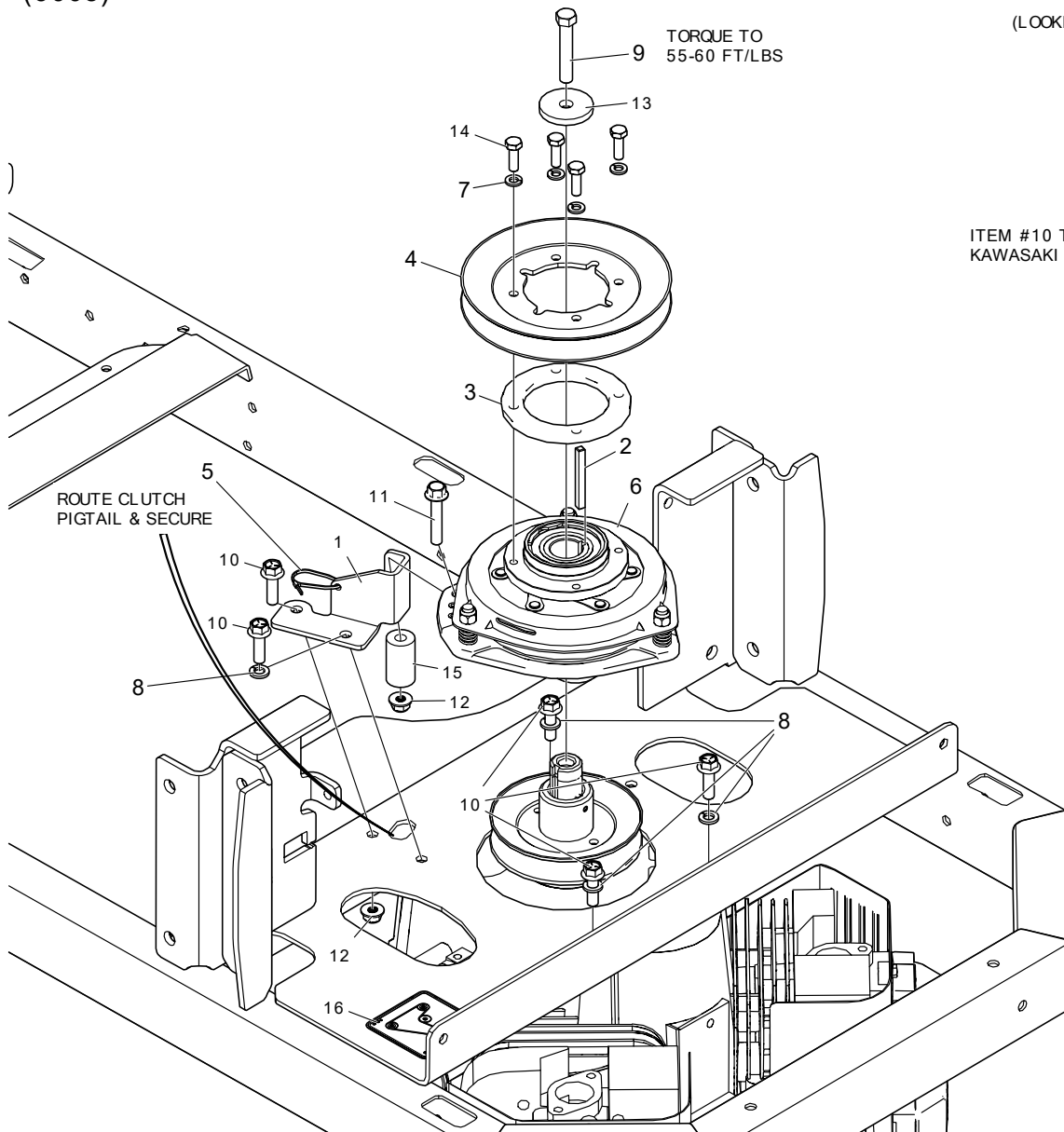

Item #	Qty	Part #	Description
1	1	724-110P	BRACKET, CLUTCH STOP (OGURA)
2	1	724-154P	KEY STOCK, 1/4 X 1/4 X 2-1/2
3	1	730-022P	SPACER, PULLEY HUB (OGURA)
4	1	D-4060	CLUTCH PULLEY, 6.75" DIA, BOLT-ON (OGURA)
5	1	E-5842	WIRE TIE
6	1	E-6710	CLUTCH, BRAKE 250 FT-LBS, 1-1/8" SHAFT
7	4	F-1019-02	LOCKWASHER
8	4	F-1019-03	LOCKWASHER, HVY, 3/8, YZ
9	1	F-2113	HHCS, 7/16-20 X 2-1/2", YZ, GR8
10	5	F-2125	FHCS, 3/8-16 X 1-1/4", YZ, GR5
11	1	F-2218	FHCS, 3/8-16 X 2-1/4", YZ, GR5
12	2	F-2151	NUT, 3/8-16 NYLOC, FLANGED, YZ
13	1	720-124P	WASHER, OGURA CLUTCH, 0.471 ID X 1.875 OD X 0.25THK
14	4	F-2299	HHCS, M8-1.25 X 25MM, GR8.8, ZINC PLATED
15	1	H-3148	BUMPER, URETHANE
16	1	P-12918	DECAL, HYDRO BELT ROUTING

# E-6711 | WIRE HARNESS

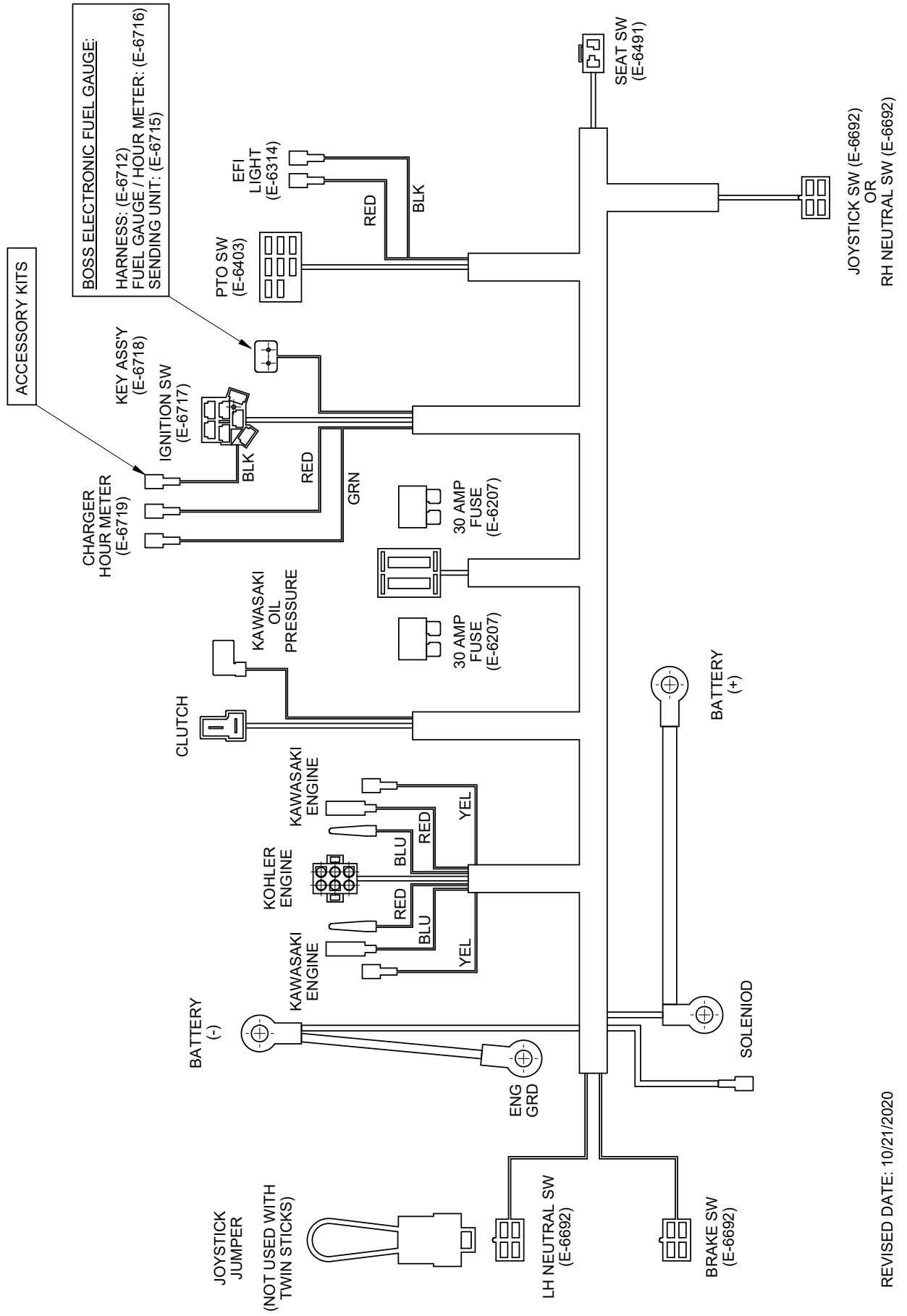

# WIRING SCHEMATIC

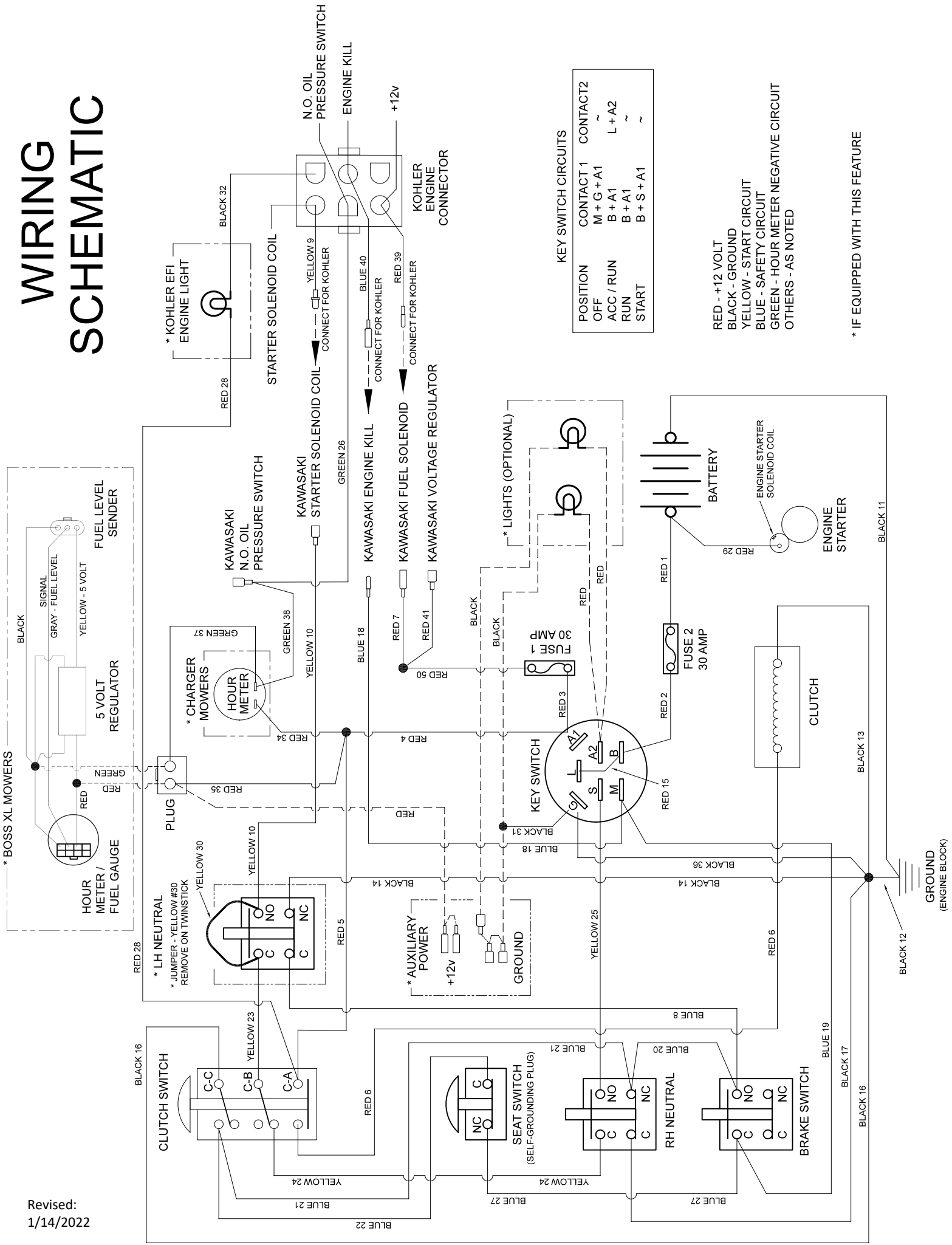

Revised: 1/14/2022

# E-6781 | EFI WIRE HARNESS

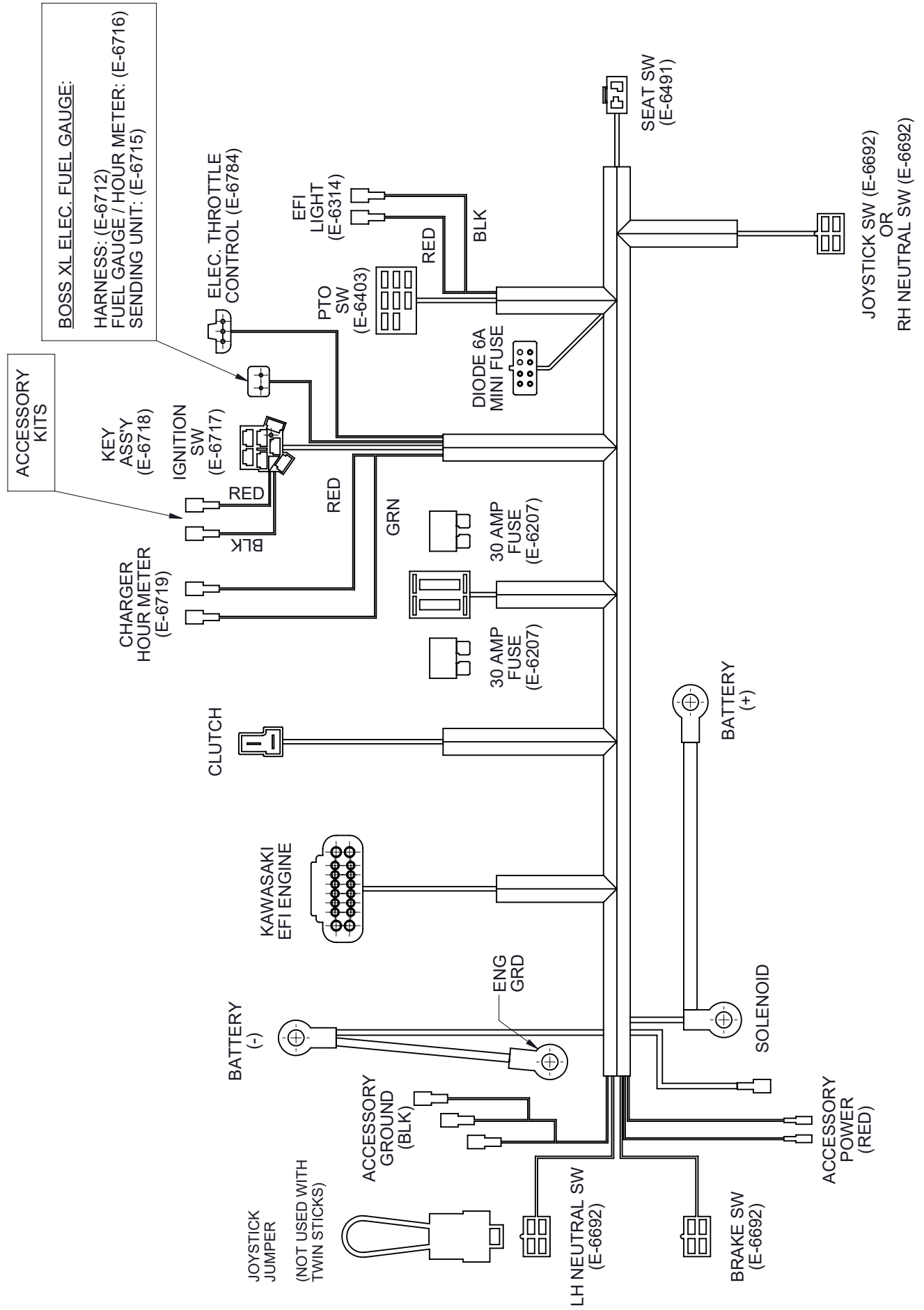

# WIRING SCHEMATIC

## KAWASAKI E.F.I.

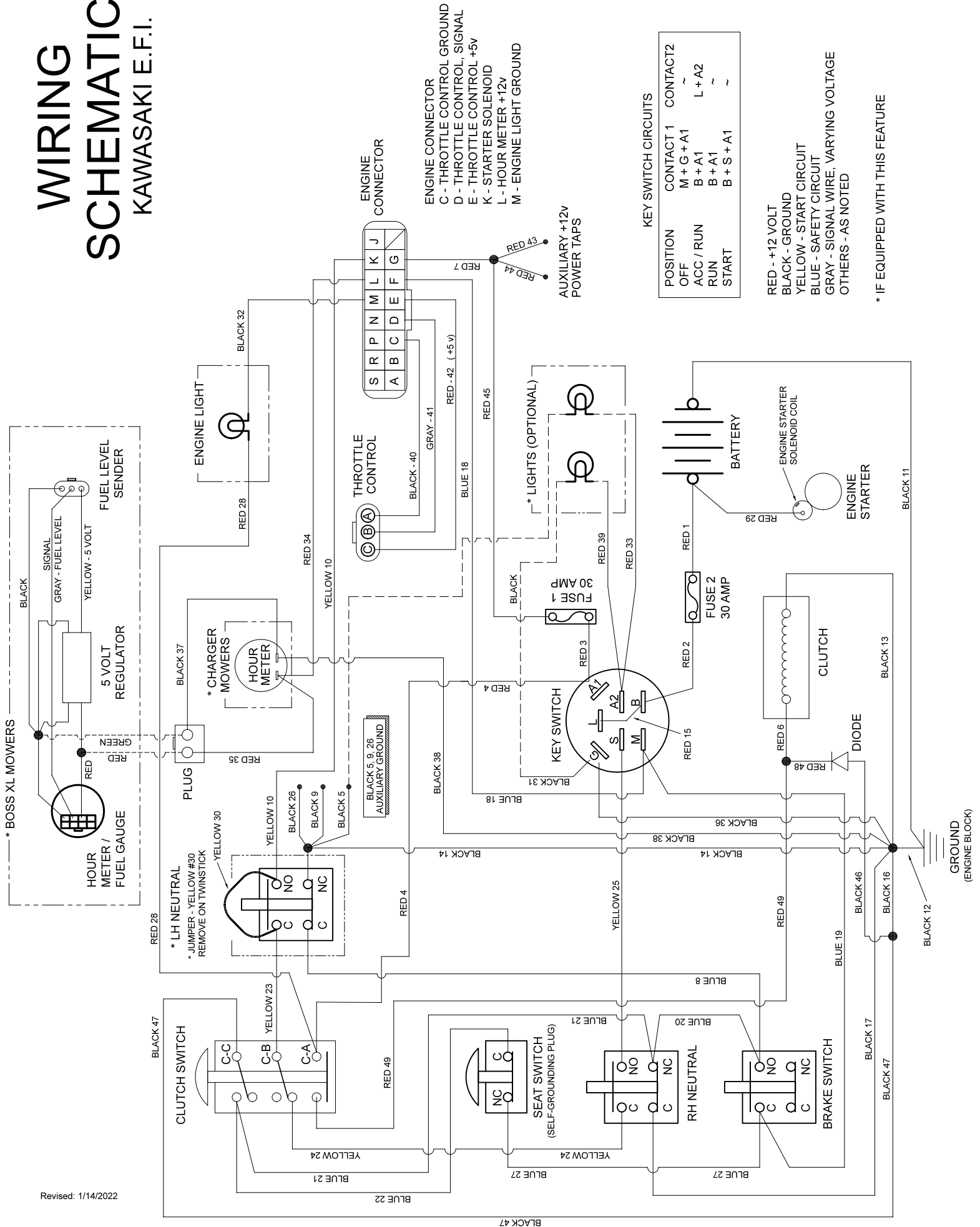

ENGINE CONNECTOR  
 C - THROTTLE CONTROL GROUND  
 D - THROTTLE CONTROL, SIGNAL  
 E - THROTTLE CONTROL +5v  
 K - STARTER SOLENOID  
 L - HOUR METER +12v  
 M - ENGINE LIGHT GROUND

### KEY SWITCH CIRCUITS

POSITION	CONTACT 1	CONTACT 2
OFF	M + G + A1	~
ACC / RUN	B + A1	L + A2
RUN	B + A1	~
START	B + S + A1	~

RED - +12 VOLT  
 BLACK - GROUND  
 YELLOW - START CIRCUIT  
 BLUE - SAFETY CIRCUIT  
 GRAY - SIGNAL WIRE; VARYING VOLTAGE  
 OTHERS - AS NOTED

\* IF EQUIPPED WITH THIS FEATURE



# COUNTRY CLIPPER LIMITED WARRANTY

Models: Boss XL

Effective October 1, 2020

## Consumer Limited Warranty

Country Clipper, a Division of Shivers Mfg., Inc. will warrant on the terms and conditions herein, that we will repair, adjust, or replace parts found by examination by the factory or by an authorized Country Clipper dealer to be defective in material, workmanship, or both, and operated and maintained as shown by Country Clipper's instructions and manuals for a period of 5 years or 1200 hours (whichever occurs first) of Residential use\* from the date of original purchase. The first three years will include parts and labor. The fourth and fifth year will be parts only.

\*Residential use is defined as use of the equipment on property the same as your primary residence or farmstead. If the equipment is used on more than one property, this is considered Commercial use, and the Commercial Warranty will apply. If usage exceeds industry norms for Residential mowing, validation of usage may be required to retain the Consumer Limited Warranty.

## Commercial Limited Warranty

When used for Commercial, business, production agriculture, horticultural or non-profit institutional use, the Limited Warranty term is 5 years or 1200 hours (whichever occurs first) from date of purchase. The first three years will provide allowance for parts and labor. The fourth and fifth year will be parts only. Mowers used for Rental purposes are not Warranted.

The Warranty applies to Country Clipper Challenger and subsequent revisions to these models sold in the United States and Canada until said warranty is revised. This Warranty applies to the original purchaser only and is non-transferable.

## Warranty Exceptions

- Normal service parts are Warranted for 90 days from the original purchase date for defects in materials or workmanship (Belts, Tires, Deck Rollers, Mower Blades, Deck Chute, and Plastic/Cloth Seat Components).
- Batteries have a 6 month Warranty by the battery manufacturer.
- Related accessories are Warranted for 1 year from their original date of purchase.
- The engine Warranty is covered by the engine manufacturer and is not Warranted by Country Clipper. The engine manufacturer's Warranty statement is included in the literature packet.
- The transmission Warranty is covered by the transmission manufacturer and is not Warranted by Country Clipper. The transmission manufacturer's Warranty statement is included in the literature packet.

## **Items and Conditions Not Covered by this Warranty**

Items and conditions not covered include:

- Pickup and delivery charges to and from authorized Country Clipper dealer.
- Repair or replacement caused by accident, misuse, neglectful or improper maintenance, improper repairs performed or parts installed, use of After Market parts, unauthorized alteration or modification, and/or normal wear and deterioration for turf equipment.
- Routine maintenance services, adjustments, cleaning and / or expendables (i.e. mower blades, lubricants, fuel, fuel filters, spark plugs, oil, oil filters, and air filters)
- Damaged incurred due to a natural disaster or exposure to the elements.
- Repairs required due to use of incompatible parts, accessories, or supplies used on the equipment other than recommended in the operator's manual or other instructional guides provided by Country Clipper.

## **Replacement Parts**

Replacement parts for Residential and Commercial use mowers that have exceeded the Warranty period are Warranted for 90 days from the date of replacement against defects in material and workmanship. A proof of purchase, of the replacement part, is required at the time the claim is submitted. Labor on replacement parts is not Warranted. Replacement parts on mowers used for Rental operation are not Warranted.

There are no other express Warranties for this product in effect during this time period.

An authorized Country Clipper dealer must perform all Warranty work using Country Clipper approved parts.

## **Obtaining Warranty Service**

**A completed Warranty registration must be submitted within 10 days of the date of purchase. If the dealer does not register the product, the customer is responsible to complete the product registration card in the literature package and return it to Country Clipper.** The servicing dealer will require a proof of purchase if the product has not been registered.

## Customer Responsibility

- The owner is responsible for delivery of the mower to the Country Clipper approved servicing dealer, within the Warranty period, and its return after Warranty work is completed.
- The owner is responsible for maintaining and adjusting the equipment as outlined in the owner's manual.
- Prompt notification to an Authorized Country Clipper Dealer or Country Clipper representative of the need for warranty repair.
- Having the warranty work performed by an authorized Country Clipper Dealer.
- Contacting the desired Country Clipper servicing dealer to arrange the service through their shop.

Contact the desired Country Clipper servicing dealer to arrange the service through their shop. Use our dealer locator at [www.countryclipper.com](http://www.countryclipper.com) or U.S. and Canada customers can call 800-344-8237 to locate their nearest dealer.

## General Conditions

Country Clipper may change the design of its products from time to time. Nothing contained in this Warranty shall be construed as obligating Country Clipper to incorporate said design changes into previously manufactured products, nor shall said changes be construed as an admission that previous designs were defective.

All implied Warranties, including those of merchantability and fitness for a particular purpose are, unless specifically required by the law of the jurisdiction, hereby excluded. Where implied Warranties are required by law, including those of merchantability and fitness for a particular purpose, they are, where allowed by the law of the State, limited to the above stated term of this Warranty. Liability for consequential damages, under any and all Warranties, both express and implied are hereby excluded unless specifically required by the statutory law of the jurisdiction. No claim of breach of Warranty shall be cause for cancellation or rescission of the contract of sale of Country Clipper equipment.

This Warranty gives you specific legal rights, and you may also have other rights, which vary from region to region.

### To obtain the nearest servicing dealer:

Dealer locator: [www.countryclipper.com](http://www.countryclipper.com)  
Email: [service@countryclipper.com](mailto:service@countryclipper.com)  
Phone: 800-344-8237 or 641-872-2544

Mail: *Country Clipper a Division of*  
Shivers Manufacturing Inc.  
613 West English St.  
Corydon, IA 50060

# KAWASAKI LIMITED WARRANTY

## FOUR-CYCLE ENGINE

Kawasaki Motors Corp., U.S.A., P.O. Box 888285, Grand Rapids, MI 49588-8285 (hereinafter "Kawasaki") warrants to the initial purchaser of each new Kawasaki four-cycle engine purchased in any of the following regions: North, Central or South America, Caribbean, Australia, New Zealand, and all territories of the United States of America (collectively, the "Purchase Area") that it will repair or replace, free of charge, any engine parts found to be defective, under normal use and proper maintenance, for a period of thirty-six (36) months, subject to the following conditions, exclusions, obligations and limitations. If you have questions about warranty coverage in your region, please contact the local Kawasaki dealer.

### 1. COVERAGE.

- a. Any factory-installed engine part found to be defective by Kawasaki within the thirty-six (36) month warranty term shall be repaired or replaced without charge for parts or labor at any authorized Kawasaki engine dealer located within the purchase area.

### 2. OWNER'S OBLIGATIONS.

The following obligations must be fulfilled by owner to maintain the validity of the Kawasaki limited warranty:

- a. Owner must deliver the four-cycle engine to an authorized Kawasaki engine dealer or equally qualified service facility for inspection, maintenance services and adjustments according to the Periodic Maintenance Chart contained in the owner's manual. The inspection, maintenance services and adjustments are to be performed at owner's expense.
- b. Owner must present proof of initial retail purchase date to an authorized Kawasaki engine dealer at the time warranty repairs are performed on the four-cycle engine.

### 3. LIMITATIONS.

This limited warranty shall not apply to or include any of the following:

- a. Repair or replacement required as a result of (i) accident, (ii) misuse or neglect, (iii) lack of reasonable and proper maintenance, (iv) repairs improperly performed or replacements improperly installed, (v) use of replacement parts or accessories not conforming to Kawasaki specifications which adversely affect performance and/or durability, (vi) alterations or modifications not recommended or approved in writing by Kawasaki, and/or (vii) wear and deterioration occasioned by the use of the four-cycle engine.
- b. Routine maintenance services, adjustments, cleaning and/or expendables such as spark plugs, lubricants, oil filters, air filters, and fuel filters.

### 4. LIMITED LIABILITY.

- a. The liability of Kawasaki under the thirty-six (36) month warranty is limited solely to the remedying of defects in factory-installed engine parts by an authorized Kawasaki engine dealer at its place of business during customary business hours. This warranty does not cover inconvenience or loss of use of the four-cycle engine or transportation of the four-cycle engine to and from the Kawasaki dealer. **KAWASAKI SHALL NOT BE LIABLE FOR ANY OTHER EXPENSE, LOSS OR DAMAGE, WHETHER DIRECT, INCIDENTAL, CONSEQUENTIAL OR EXEMPLARY ARISING IN CONNECTION WITH THE SALE OR USE OF OR INABILITY TO USE THE KAWASAKI FOUR-CYCLE ENGINE FOR ANY PURPOSE. SOME STATES DO NOT ALLOW THE EXCLUSION OR LIMITATIONS OF ANY INCIDENTAL OR CONSEQUENTIAL DAMAGES, SO THE ABOVE LIMITATION OR EXCLUSION MAY NOT APPLY TO YOU.**
- b. **NO EXPRESS WARRANTY IS GIVEN BY KAWASAKI WITH RESPECT TO THE KAWASAKI FOUR-CYCLE ENGINE EXCEPT AS SPECIFICALLY SET FORTH HEREIN. ANY WARRANTY IMPLIED BY LAW, INCLUDING ANY WARRANTY OF MERCHANTABILITY OR FITNESS FOR A PARTICULAR PURPOSE, IS EXPRESSLY LIMITED TO THE THIRTY-SIX (36) MONTH WARRANTY TERM SET FORTH HEREIN. THE FOREGOING STATEMENTS OF WARRANTY ARE EXCLUSIVE AND IN LIEU OF ALL OTHER REMEDIES. SOME STATES DO NOT ALLOW LIMITATIONS ON HOW LONG AN IMPLIED WARRANTY LASTS, SO THE ABOVE LIMITATIONS MAY NOT APPLY TO YOU.**
- c. No distributor, dealer or other four-cycle engine reseller is authorized to modify this Kawasaki Limited Four-Cycle Warranty.

### 5. LEGAL RIGHTS.

**THIS WARRANTY GIVES YOU SPECIFIC LEGAL RIGHTS, AND YOU MAY ALSO HAVE OTHER RIGHTS WHICH VARY FROM STATE TO STATE .**

## EMISSION CONTROL SYSTEM WARRANTY STATEMENT

This warranty statement outlines the emission warranty coverage provided by Kawasaki Motors Corp. U.S.A. ("Kawasaki") for small off-road engines sold in the U.S. and its territories, as well as the 13 provinces and territories of Canada. This warranty statement is divided into two parts. Part I warrants that a new Kawasaki small off-road engine complies with U.S. EPA and Environment Canada emissions regulations. Part II warrants that a new Kawasaki small off-road engine certified for sale in California also complies with the State of California's emissions regulations.

### Part I: United States and Canada

#### *Your Warranty Rights and Obligations*

Your new small off-road engine must be designed, built and equipped to meet the U.S. EPA emission standards for small off-road engines with maximum engine power at or below 19 kilowatts or an engine displacement less than 1 liter. Kawasaki must warrant the emission control system on your small off-road engine for the period of time listed below, provided there has been no abuse, neglect, or improper maintenance of your small off-road engine. Where a warrantable condition exists, Kawasaki will repair your small off-road engine at no cost to you including diagnosis, parts, and labor.

Your emission control system may include such parts as the carburetor or fuel injection system, the ignition system, and catalytic converter. Also included may be hoses, connectors, and other emission-related assemblies. For a list of the emission control system parts covered under this warranty, please contact your nearest Kawasaki Dealer or contact Kawasaki directly at 877-364-6404.

#### *Warranty Coverage*

Kawasaki warrants to the original retail purchaser, and each subsequent purchaser, that the small off-road engine, including all parts of its emission control system, is:

1. designed, built, and equipped to conform to the U.S. EPA and Environment Canada emission standards at the time of sale to the original retail purchaser; and
2. free from defects in materials and workmanship that may keep it from meeting the requirements under these emission standards.

This warranty begins on the date the small off-road engine is delivered to the original retail purchaser and extends for a period of three years. This warranty covers all components whose failure would increase the emissions of any regulated pollutant. This warranty does not cover components whose failure would not increase the engine's emissions of any regulated pollutants.

#### *Owner's Warranty Responsibility*

As the small off-road engine owner, you are responsible for the performance of the required maintenance listed in your owner's manual. Kawasaki recommends that you retain all receipts covering maintenance on your small off-road engine, but Kawasaki cannot deny warranty coverage solely for the lack of receipts or for your failure to ensure the performance of all scheduled maintenance.

As the small off-road engine owner, you should, however, be aware that Kawasaki may deny you warranty coverage if your small off-road engine or a part has failed due to abuse, neglect, improper maintenance, or unapproved modifications.

You are responsible for presenting your small off-road engine to a Kawasaki dealer as soon as a problem exists. The emission related warranty repairs should be completed in a reasonable amount of time, not to exceed 30 days.

If you have any questions regarding your emission warranty rights and responsibilities, you should contact:

Kawasaki Motors Corp. U.S.A.  
Consumer Services Department  
5080 36th Street S.E.  
Grand Rapids, MI 49512  
Telephone: (877) 364-6404  
Email: kawpower-website@kmc-usa.com

#### *To Obtain Warranty Service*

You must, at your own expense, take your Kawasaki small off-road engine or the product on which it is installed, along with proof of original purchase date, to any Kawasaki Dealer who is authorized by Kawasaki to sell and service that Kawasaki product during the Dealer's normal business hours. Claims for repair or adjustments found to be caused solely by defects in material or workmanship will not be denied because the engine was not properly maintained and used.

If however, you reside more than 100 miles from an authorized service center in the contiguous states, excluding certain high-altitude areas, Kawasaki will either pay for shipping costs to and from an authorized service center, provide for a service technician to come to the owner to make the warranty repair, or pay for the repair to be made at a local non-authorized service center. If you are unable to obtain emission warranty service or are dissatisfied with the warranty service you received, contact the owner of the dealership involved. However, if you require further assistance, contact Kawasaki directly via the contact information above.

#### *Exclusions*

Failures other than those resulting from defects in material or workmanship are not covered by this warranty. This warranty does not extend to emission control systems and parts that are affected or damaged by owner abuse, misuse, neglect, improper maintenance or repairs, misfueling, improper storage, collision, the use of unsuitable attachments, or the unauthorized alteration of any part.

This warranty does not cover replacement of parts or other services and adjustments necessary for required maintenance at and after the first scheduled replacement point.

#### *Disclaimer of Consequential Damages and Limitation of Implied Warranties*

Kawasaki Motors Corp. disclaims responsibility for incidental or consequential damages such as loss of time or the use of the power equipment, or any commercial loss due to the failure of the equipment; and any implied warranties are limited to the duration of this written warranty. This warranty is applicable only where the California, U.S. EPA, or Environment Canada emission control system warranty regulation is in effect.

### Part II: CALIFORNIA EMISSIONS CONTROL WARRANTY STATEMENT

#### *Your Warranty Rights and Obligations*

The California Air Resources Board and Kawasaki are pleased to explain the emission control system warranty on your model year 2021/2022 small off-road engine. In California, new small off-road engines must be designed, built, and equipped to meet the State's stringent anti-smog standards. Kawasaki must warrant the emission control system on your small off-road engine for the periods of time listed below provided there has been no abuse, neglect or improper maintenance of your small off-road engine.

Your emission control system may include such parts as the carburetor or fuel injection system, the ignition system, and catalytic converter. Also included may be hoses, belts, connectors, and other emission-related assemblies.

Where a warrantable condition exists, Kawasaki will repair your small off-road engine at no cost to you including diagnosis, parts and labor.

#### *Manufacturer's Warranty Coverage*

The 1995 and later small off-road engines are warranted for three years. If any emission-related part on your small off-road engine is defective, the part will be repaired or replaced by Kawasaki.

#### *Owner's Warranty Responsibility*

As the small off-road engine owner, you are responsible for the performance of the required maintenance listed in your owner's manual. Kawasaki recommends that you retain all receipts covering maintenance on your small off-road engine, but Kawasaki cannot deny warranty coverage solely for the lack of receipts or for your failure to ensure the performance of all scheduled maintenance.

As the small off-road engine owner, you should however be aware that Kawasaki may deny you warranty coverage if your small off-road engine or a part has failed due to abuse, neglect, improper maintenance, or unapproved modifications.

You are responsible for presenting your small off-road engine to a Kawasaki distribution center as soon as a problem exists. The warranty repairs should be completed in a reasonable amount of time, not to exceed 30 days.

If you have any questions regarding your warranty rights and responsibilities, you should contact:

Kawasaki Motors Corp. U.S.A.  
Consumer Services Department  
5080 36th Street S.E.  
Grand Rapids, MI 49512  
Telephone: (877) 364-6404  
Email: kawpower-website@kmc-usa.com

### **General Emissions Warranty Coverage**

Kawasaki warrants to the ultimate purchaser and each subsequent purchaser that the small off-road engine is:

1. designed, built, and equipped so as to conform with all applicable regulations adopted by the Air Resources Board pursuant to its authority in Chapters 1 and 2, Part 5, Division 26 of the Health and Safety Code; and
2. free from defects in materials and workmanship that cause the failure of a warranted part to be identical in all material respects to the part as described in Kawasaki's application for certification.

The warranty period begins on the date the engine or equipment is delivered to an ultimate purchaser or first placed into service. The equipment or engine owner will not be charged for diagnostic labor that is directly associated with diagnosis of a defective, emission-related warranted part, provided that such diagnostic work is performed at a Kawasaki warranty station.

Engine parts outlined in the Periodic Maintenance Chart found in the Owners Manual provided with this engine, are warranted as follows:

1. Any warranted part that is not scheduled for replacement as required maintenance in the Periodic Maintenance Chart, is warranted for the warranty period stated above. If any such part fails during the warranty period, the part will be repaired or replaced by Kawasaki at no charge to the owner provided the repair or replacement is performed at a warranty station. Any such part repaired or replaced under the warranty will be warranted for the remaining warranty period.
2. Any warranted part that is scheduled only for regular inspection in the Periodic Maintenance Chart is warranted for the warranty period stated above. Any such part repaired or replaced under warranty will be warranted for the remaining warranty period.
3. Any warranted part that is scheduled for replacement as required maintenance in the Periodic Maintenance Chart is warranted for the period of time before the first scheduled replacement date for that part. If the part fails before the first scheduled replacement, the part will be repaired or replaced by Kawasaki at no charge to the owner provided the repair or replacement is performed at a warranty station. Any such part repaired or replaced under warranty will be warranted for the remainder of the period prior to the first scheduled replacement point for the part.

Kawasaki is liable for damages to other engine components proximately caused by a failure under warranty of any warranted part.

Throughout the engine's warranty period defined above, Kawasaki will maintain a supply of warranted parts sufficient to meet the expected demand for such parts. Any replacement part may be used in the performance of any warranty maintenance or repairs and will be provided without charge to the owner. Such use will not reduce the warranty obligations of Kawasaki.

Add-on or modified parts, as defined in Section 1900(b)(1) and (b)(14), Title 13, that are not exempted by the Air Resources Board may not be used. The use of any non-exempted add-on or modified parts by the ultimate purchaser will be grounds for disallowing a warranty claim made in accordance with this article. Kawasaki will not be liable under this article to warrant failures of warranted parts caused by the use of a non-exempted add-on or modified part.

#### **To Obtain Warranty Service**

Notwithstanding the provisions herein, warranty services or repairs will be provided at all Kawasaki distribution centers that are franchised to service the subject engines.

You must, at your own expense, take your Kawasaki small off-road engine or the product on which it is installed, along with proof of original purchase date, to any Kawasaki Dealer who is authorized by Kawasaki to sell and service that Kawasaki product during the Dealer's normal business hours. Claims for repair or adjustments found to be caused solely by defects in material or workmanship will not be denied because the engine was not properly maintained and used.

If you are unable to obtain emission warranty service or are dissatisfied with the warranty service you received, contact the owner of the dealership involved. However, if you require further assistance, contact the Kawasaki office in your region:

Kawasaki Motors Corp., U.S.A.  
Consumer Services Department  
5080 36th Street S.E.  
Grand Rapids, MI 49512  
Telephone: (877) 364-6404  
Email: kawpower-website@kmc-usa.com

#### **Exclusions**

1. The repair or replacement of any warranted part otherwise eligible for warranty coverage as stated above may be excluded from such warranty coverage if Kawasaki demonstrates that the engine has been abused, neglected, or improperly maintained, and that such abuse, neglect, or improper maintenance was the direct cause of the need for repair or replacement of the part.
2. Kawasaki warrants your engine only for the warranty period specified above.
3. Except as provided above, any adjustment of a component that has a factory installed, and properly operating, adjustment limiting device (such as an idle limiter cap or plug) is eligible for warranty coverage as stated above.

#### **Disclaimer of Consequential Damage and Limitation of Implied Warranties:**

Kawasaki Motors Corp. disclaims responsibility for incidental or consequential damages such as loss of time or the use of the power equipment, or any commercial loss due to the failure of the equipment; and any implied warranties are limited to the duration of this written warranty. This warranty is applicable only where the California, U.S. EPA, or Environment Canada emission control system warranty regulation is in effect.

#### **Warranted Parts List:**

The following is the emission warranty parts list for your small off-road engine:

- (i) Fuel Metering System
  - (A) Carburetor and internal parts (and/or pressure regulator or fuel injection system)
  - (B) Cold start enrichment system
  - (C) Intake valve(s)
- (ii) Air Induction System
  - (A) Intake manifold
  - (B) Air filter
- (iii) Ignition System
  - (A) Spark plugs
  - (B) Magneto or electronic ignition system
  - (C) Spark advance/retard system
  - (D) Ignition coil and/or control module
- (iv) Lubrication System
  - (A) Oil pump and internal parts
- (v) Positive Crankcase Ventilation (PCV) System
  - (A) PCV valve
  - (B) Oil filler cap
- (vi) Catalyst or Thermal Reactor System
  - (A) Catalytic converter
  - (B) Exhaust manifold
  - (C) Exhaust valve(s)

Kawasaki Motors Corp., U.S.A.  
Consumer Services Department  
5080 36th Street S.E.  
Grand Rapids, MI 49512  
Telephone: (877) 364-6404  
Email: kawpower-website@kmc-usa.com



**All Models**

---

**Warranty**

---

**Policies and Procedures**

---



## Hydro-Gear® Warranty Policies and Procedures

### Limited Warranty

BLN-50225\_P18 March, 2019

Hydro-Gear Limited Partnership (hereinafter referred to as "Hydro-Gear") warrants to the original equipment manufacturer (OEM), authorized distributor, or authorized servicing dealer purchasing a Hydro-Gear product or replacement parts (such purchaser is hereinafter referred to as "Buyer") that the product or replacement parts will be free from defects in material and workmanship at the time of shipment from Hydro-Gear, and will conform to such drawings and specifications as are applicable to the product or replacement parts under Hydro-Gear's sales agreement with Buyer.

The duration of this limited warranty is as set forth in the section below under the heading "WARRANTY PERIODS." During the applicable period of warranty, Hydro-Gear shall repair or replace at its option those products or their parts which are found by Hydro-Gear to be defective in material or workmanship at time of shipment, provided that Hydro-Gear or its authorized representative is first advised in writing of Buyer's contention of such defect (during such warranty period) and provided further, that the product or, if applicable, the replacement part in question is made available for inspection by Hydro-Gear or its authorized representative. To facilitate inspection, Hydro-Gear may request return of the product and/or part which Buyer contends to be defective. Product or parts failures or malfunctions which are not attributable to defects in material and/or workmanship, and which are not covered by the said warranty include, but are not limited to:

- \* Inadequate, contaminated, or improper fluid.
- \* Accident, abuse, improper maintenance, or neglect.
- \* Stripped keyways, or splines stripped or worn on external shaft end.
- \* Improper mounting of external pulleys, gears, couplings, etc.
- \* Improper electrical connection or power supply.
- \* Corrosion, or other damage, resulting from battery acid leakage.
- \* Operating above those speeds, weights limits, pressures, or temperatures recommended by Hydro-Gear.
- \* Use of the product in a manner or for a purpose not originally intended for by Hydro-Gear or failure to use in strict accordance with Hydro-Gear's written instructions.
- \* Repairs or installation by personnel other than as authorized by Hydro-Gear.
- \* Transportation.
- \* Use of parts other than Genuine Hydro-Gear Parts or other parts authorized in writing by Hydro-Gear.
- \* Misdiagnosis of component failure.
- \* Maintenance items such as filters, oil, etc.

THE WARRANTIES SET FORTH HEREIN ARE IN LIEU OF AND TO THE EXCLUSION OF ALL OTHER WARRANTIES, WHETHER EXPRESS, IMPLIED, OR STATUTORY, INCLUDING BUT NOT BY WAY OF LIMITATION, WARRANTIES OF MERCHANTABILITY OR FITNESS FOR A PARTICULAR PURPOSE.

HYDRO-GEAR'S LIABILITY, WHETHER OF WARRANTY, NEGLIGENCE, OR OTHERWISE, IS LIMITED TO THE REPAIR OR REPLACEMENT AS HEREIN PROVIDED OR, AT HYDRO-GEAR'S SOLE OPTION, TO A REFUND OF THE PURCHASE PRICE. **THIS SHALL BE HYDRO-GEAR'S SOLE AND MAXIMUM LIABILITY AND UNDER NO CIRCUMSTANCES SHALL HYDRO-GEAR BE LIABLE FOR LIQUIDATED, SPECIAL, INCIDENTAL OR CONSEQUENTIAL DAMAGES.**

If Buyer grants warranty on Hydro-Gear products of greater scope than the warranties provided by Hydro-Gear, or extends any warranty period beyond the applicable period described in "**WARRANTY PERIODS,**" Buyer does so at its sole risk and expense and Buyer will indemnify and hold Hydro-Gear harmless from any claims of any party based on such greater warranty or period, and any expenses incurred in the defense of such claims. This warranty only applies to OEM's, authorized distributors, authorized servicing dealers, and by its terms does not extend to any person buying the product from such OEM, authorized distributor, or authorized servicing dealer, for personal, family, or household use. If Buyer makes available the benefits of this warranty to its customer, and if the Magnuson-Moss Warranty Improvement Act (Pub. L. 93-637) or similar state laws should apply, Buyer assumes all responsibility for compliance with such laws and any expenses incurred in the defense of any such claims, thereunder.



**Note: Proof of purchase must be available if requested to assist in determining commencement of the warranty period. If proof of purchase is not available, the Hydro-Gear Serial Number will determine the commencement of the warranty period.**

## **I. ORIGINAL (OEM) INSTALLED PRODUCTS<sup>Δ</sup>**

### **A. REVIEWED TWO YEAR NONCOMMERCIAL\* USAGE** (See Figure 1, Hydro-Gear Warranty Time Frames)

The warranty period shall be limited to the earlier of:

- (i) 24 consecutive months (2 years) from the date of first sale\*\* of the product, or
- (ii) 24 consecutive months (2 years) from the date of manufacture if proof of purchase is not available upon request, and is subject to a limitation of 48 consecutive months (4 years) from the date of manufacture.\*\*\*

### **B. REVIEWED ONE YEAR COMMERCIAL USAGE** (See Figure 1, Hydro-Gear Warranty Time Frames)

The warranty period shall be limited to the earlier of:

- (i) 12 consecutive months (1 year) from the date of the first sale of the product, or
- (ii) 90 days from the date of the first sale of the product on Rental applications; or
- (iii) 12 consecutive months (1 year) from the date of manufacture if proof of purchase is not available upon request, and is subject to a limitation of 48 consecutive months (4 years) from the date of manufacture.

### **C. REVIEWED TWO YEAR COMMERCIAL USAGE** (See Figure 1, Hydro-Gear Warranty Time Frames)

The warranty period shall be limited to the earlier of:

- (i) 24 consecutive months (2 years) from the date of the first sale of the product, or
- (ii) 90 days from the date of the first sale of the product on Rental applications; or
- (iii) 24 consecutive months (2 years) from the date of manufacture if proof of purchase is not available upon request, and is subject to a limitation of 48 consecutive months (4 years) from the date of manufacture.

## **II. REPLACEMENT PARTS AND UNITS<sup>Δ</sup>**

### **A. HYDRO-GEAR REPLACEMENT PARTS**

- (i) All parts shall be warranted for 90 days from the date of first sale, or the balance of the original product warranty, whichever is longer.
- (ii) This warranty is subject to a limitation of 48 consecutive months (4 years) from the date of manufacture.

### **B. HYDRO-GEAR REPLACEMENT UNITS**

- (i) Replacement units shall be warranted for 180 days from the date of first sale, or the balance of the original product warranty, whichever is longer.
- (ii) Nevertheless, the warranty period for replacement units in Rental applications is limited to 90 days from the date of first sale.
- (iii) These warranties for replacement units are subject to a limitation of 48 consecutive months (4 years) from the date of manufacture.

<sup>Δ</sup> All Product repairs and replacements must be performed by an authorized dealer or service center to prevent Hydro-Gear's warranty from being voided.

\* Noncommercial - any vehicle not reviewed for commercial use by Hydro-Gear.

\*\* First sale - is considered the date a vehicle, replacement part or replacement unit is first sold by Buyer (OEM, authorized distributor, or authorized servicing dealer).

\*\*\* 48 consecutive months (4 years) from the date of manufacture – Any warranty period listed herein will remain in effect for its entire duration on any sale of the product by Buyer occurring up to 48 consecutive months (4 years) from the date of manufacture by Hydro-Gear. Hydro-Gear will not reimburse Buyer on warranty claims pertaining to products sold by Buyer more than 48 consecutive months (4 years) from the date of manufacture by Hydro-Gear. In the latter case, any warranty offered by Buyer is at the sole risk and expense of Buyer. In such case, Buyer will indemnify and hold Hydro-Gear harmless from the claims of any party based on such warranty, and from any expenses incurred in the defense of such claims.

# Warranty Claims Procedure

- A. Claims submitted to Hydro-Gear will require a Hydro-Gear, OEM, Outdoor Power Equipment Institute (OPEI) or equivalent claim form from the servicing dealer. Dealer claims must provide all pertinent information typical on OPEI claim forms, i.e., owner's name, servicing dealer, Hydro-Gear Serial Numbers, symptoms, repair date, and type of use, etc.
- B. Complete Hydro-Gear product Model Number and Serial Number must be provided.
- C. All claims must be filed within 45 days of unit failure.
- D. Warranty claims will be processed in accordance with: BLN-51371 for the United States and Canada; BLN-51373 for Europe, and BLN-51374 for Australia.
- E. Hydro-Gear reserves the right to reduce or reject a warranty claim which does not comply with the stated procedures.
- F. Warranty labor rate(s) will be set by Hydro-Gear.
- G. Labor rate time guidelines will be as follows:

Hydraulic Units		Electric Units	
Hydraulic Unit Replacement	Up to Two hours maximum	Electric Unit (Transaxle) Replacement	Up to Two hours maximum
Hydraulic External Repair	Up to One hour maximum	Electric Unit (Transaxle) External Repair	Up to One hour maximum
Hydraulic Internal Repair	Up to Three hours maximum	Electric Unit (Transaxle) Internal Repair	Up to Three hours maximum
		Electric Component Replacement or Repair	Up to One hour maximum

Hydro-Gear Warranty Time Frames			
Hydraulic Product Group	2 Year Noncommercial Usage	1 Year Commercial Usage	2 Year Commercial Usage
ZT-1800 / ZT-2100 / ZT-2200 (EZT) ZT-2800	Yes	No	No
ZT-3100 / ZT-3200	Yes	Yes	No
ZT-3400 / ZT-3600 / ZT-3800 / ZT-4400 / ZT-5400	Yes	-	Yes
SST	Yes	No	No
RT-310	Yes	Yes	No
T1 / T2 / T3	Yes	No	No
310-0510 / 310-0610 / 310-0710	Yes	No	No
310-2000 / G700 / 310-3000 / 310-3500	Yes	No	No
Pumps (PC)	Yes	Yes	No
Pumps (PJ, PE, PL, PG, PK, PR, PW, PY)	Yes	-	Yes
Piston Motor (HGM-H, PRM)	Yes	-	Yes

Figure 1: Hydraulic Warranty Time Frames

Smartec Warranty Time Frames			
Electric Product Group	2 Year Noncommercial Usage	1 Year Commercial Usage	2 Year Commercial Usage
Electric Drive - ZT	Yes	No	No
Electric Drive - LT	Yes	No	No

Figure 2: Smartec Warranty Time Frames

- a) All warranty times listed in Figures 1 & 2 are for products originally installed in a machine by an OEM manufacturer.
- b) See sections I(B), I(C), II(A) and II(B) on the **Warranty Periods** page for Rental Application, Replacement Part, and Replacement Unit warranty information.



## Battery Warranty Terms

The OE Interstate Battery will be covered under a free replacement warranty for 6 months. This warranty period will begin the date the lawnmower is purchased by the end user.

## Battery Warranty Process

If you have a lawnmower that won't start, please complete these steps before calling for a warranty replacement. Completion of these steps before calling will expedite the warranty process.

1. Check the voltage of the battery. If the voltage reading is at or below 12.60 volts, the battery is most likely discharged and needs a slow recharge. If this is the case, move to step 2. If your battery's voltage is above 12.60 volts, move to step 5.
2. Charge the battery with a slow charger (4 amps or less). If you have an automatic shut-off charger, connect the battery to the charger and let the charger complete its charge cycle. If using a manual charger, utilize the following chart to determine necessary recharge time (a 15-60 minute charge WILL NOT be a sufficient recharge for a discharged battery and will be refused for warranty):

### Open Circuit Voltage

Battery Voltage	State of Charge	Recommended Charge Time (Hours)		
		1 Amp	2 Amps	4 Amps*
12.84	100%	0	0	0
12.60	70%	20	10	5
12.40	50%	32	16	8
12.20	25%	52	26	13
12.00	0%	72	36	18

3. Once recommended charging time is complete, let battery rest for as long as possible (up to 24 hours) to deplete surface charge and increase testing accuracy.
4. Check voltage again. If the battery's voltage is still below 12.60 volts, repeat step 2. If voltage is above 12.60 volts, move to step 5.
5. Load test the battery according the instructions of your load tester and to the ratings of the battery. If the battery passes the load test, it can be re-installed in the lawnmower.
6. If the battery fails the load test, please contact Interstate Batteries at the number below to process the warranty battery. Please have the battery with you as the part number and manufacturer's date code will be required.

**Interstate Batteries of NWMO**  
**(816) 424-3417**  
**sales@myinterstatestore.com**

## SPECIFICATIONS

### BOSS XL - Joystick Steering

MODEL	3160KAJ-9005	3560KAJ-9005	3572KAJ-9005
Engine	31 H.P. Kawasaki FX921V (999cc)	35 H.P. Kawasaki FX1000V (999cc)	
Hydrostatic Transmission	Hydro-Gear ZT5400		
Steering Control	Single Joystick		
Fuel Capacity	10.25 Gallons		
Tires, Rear	26x12-12		
Tires, Front	15x6-6		
Turning Radius	Zero-Turn		
Ground Speed Forward	12-1/2 MPH (infinitely variable)		
Reverse	7-1/2 MPH (infinitely variable)		
Length	84-1/2"		86"
Height	48-1/2" (Folded R.O.P.S.)		75-1/2" (Top of R.O.P.S.)
Width, Tractor (outside rear tires)	58-1/2"		
Width, Deck (with deck chute up)	61"		73"
(with deck chute down)	73"		85"
Cutting Width	60"		72"
Blade Length (3 per deck)	21"		25"
Cutting Height	1.5" to 5" (1/4" increments)		
Weight (approx.)	1330#	1330#	1413#
Standard Features	Hour Meter, Cup Holder, Storage Tray, Electric Start, Electric Fuel Gauge, Trailer Hitch Receiver, ContourDTS Deck Suspension, Auto Detach Stand-Up Deck, R.O.P.S. (Roll Over Protection System), Suspension Seat w/ 3" Adjustable Travel, Vibration Isolators, Adjustable Seat Back Recline and Adjustable Lumbar Support		

### BOSS XL - Twinstick Steering

MODEL	3560KAT-9005	3572KAT-9005
Engine	35 H.P. Kawasaki FX1000V (999cc)	
Hydrostatic Transmission	Hydro-Gear ZT5400	
Steering Control	Twinstick	
Fuel Capacity	10.25 Gallons	
Tires, Rear	26x12-12	
Tires, Front	15x6-6	
Turning Radius	Zero-Turn	
Ground Speed Forward	12-1/2 MPH (infinitely variable)	
Reverse	7-1/2 MPH (infinitely variable)	
Length	84-1/2"	86"
Height	48-1/2" (Folded R.O.P.S.)	75-1/2" (Top of R.O.P.S.)
Width, Tractor (outside rear tires)	58-1/2"	
Width, Deck (with deck chute up)	61"	73"
(with deck chute down)	73"	85"
Cutting Width	60"	72"
Blade Length (3 per deck)	21"	25"
Cutting Height	1.5" to 5" (1/4" increments)	
Weight (approx.)	1338#	1421#
Standard Features	Hour Meter, Cup Holder, Storage Tray, Electric Start, Electric Fuel Gauge, Trailer Hitch Receiver, ContourDTS Deck Suspension, Auto Detach Stand-Up Deck, R.O.P.S. (Roll Over Protection System), Suspension Seat w/ 3" Adjustable Travel, Vibration Isolators, Adjustable Seat Back Recline and Adjustable Lumbar Support	

*Specifications subject to change without prior notice*



# **PRODUCT MANUAL**

**BOSS<sup>XL</sup> 9005**

## **Country Clipper Division**

Shivvers Manufacturing, Inc.

613 W. English St.

Corydon, IA 50060-0467

Ph. 641-872-2544

Fax. 641-872-1593

P-13542 (Rev C - 1/22)