

**SERIES 500, 1000, 1300 and 1600
CABLE LIFT**

**SAFETY & WARRANTY INFORMATION,
OPERATOR'S INSTRUCTIONS
AND
MAINTENANCE MANUAL**



CAUTION

Before installing this Lift Gate, please observe the Vehicle Loading Limitations. These loading limitations are outlined in the Vehicle Owner's Manual and the Safety Compliance Certification Label located on the drivers door pillar.



CAUTION

TO THE OWNER\OPERATOR:

Read this manual completely before using your gate. Operate and maintain your gate safely as outlined in this manual. Be sure you read and understand all operating, safety, maintenance and service information. Should you need repair or service information, contact Tommy Gate or an authorized distributor for assistance.



This is the safety alert symbol. It is used to alert you to potential personal injury hazards. Obey all safety messages that follow this symbol to avoid possible injury or death.



DANGER indicates an imminently hazardous situation which, if not avoided, will result in death or serious injury.



WARNING indicates a potentially hazardous situation which, if not avoided, could result in death or serious injury.



CAUTION indicates a potentially hazardous situation which, if not avoided, may result in minor or moderate injury.

Safety is a primary concern in the design and manufacture of our products. Unfortunately, our efforts to provide safe equipment can be wiped out by a single careless act of an operator.

Accident prevention and safety are dependent upon the awareness, concern, prudence and proper training of the personnel who operate, transport, maintain and store this equipment. It is your responsibility to use good judgment in the operation of this equipment.

It has been said that **"the best safety device is an informed, careful operator."** We ask you to be that kind of operator.

DECAL LOCATIONS

Locate and read all decals prior to operating gate

REPLACE IF MISSING OR NOT READABLE

To replace decal, clear area of grease and dirt with non-flammable solvent, then soap and water. Allow to dry. To apply decal, peel off 1/2 of back. Hold decal squarely and apply to cleaned surface. Peel off remaining back and smooth in place. Gently rub decal with a damp rag or sponge to smooth out bubbles. (The decal has a pressure-sensitive adhesive on the back.)

If the liftgate is going to be painted, you need to paper premask the decals before painting. Remove the paper premask after painting so the decals can be read clearly.

NOTE: When ordering Decals, please have Decal Numbers available.

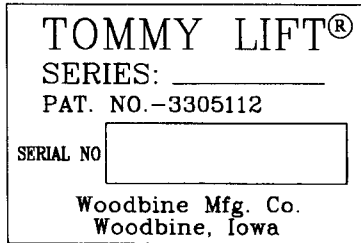

Decal No. 1
Located above pump and motor unit.
Serial number indicates manufacturer
of pump; Series number indicates
capacity of Lift.

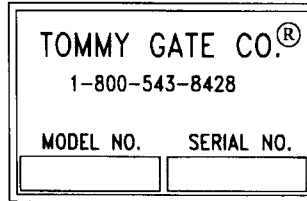

Decal No. 2
Metal plate located on side of upright.



Decal No. 3
Located on the side of uprights

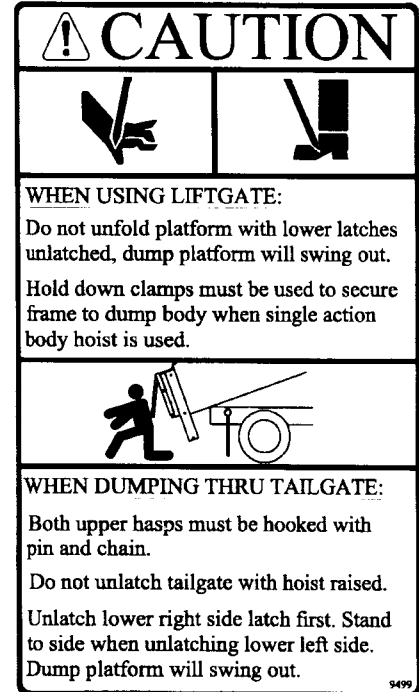

Decal No. 4
Placed on every lift and dump model.
Located on the outside bottom right-hand
corner of the platform.

⚠ WARNING



Do not ride the platform.
This lift is not designed as a wheelchair or personnel lift.

Center Load



Center load on platform side to side and front to back.

Never allow children or any untrained person to operate the lift.

Do not show children or others how to operate the lift.

When the lift is not in use or unattended, the platform should be closed and latched with control secured.

Decal No. 5

Located on left-hand upright inside the frame.
(Or on right hand side of lift and dump models.)

⚠ WARNING



Keep one hand on the platform when opening and closing.

Platform opening and closing forces/weights will vary if your vehicle is on an incline.

Stand clear of all moving parts when opening, raising or lowering platform.

Never leave the platform down to be used as a step.

Do not add any extension to original platform.

Decal No. 6

Located on the outside right-hand corner of the platform.

⚠ CAUTION



Spring under high tension

Decal No. 7

Located on the upright next to the torsion spring and safety holder on models with torsion assist spring.

⚠ DANGER



Before removing box cover, the platform must be closed and latched or lowered to the ground with the control disarmed.

Decal No. 10

Located on box cover of gate.

⚠ WARNING

Read operator's manual before operating equipment.

Do not modify lift or its safety features.

Use only Tommy Gate service parts installed by an authorized distributor.

If additional assistance is needed, call Tommy Gate at 800-543-8428.

Do not exceed the rated lift capacity-

Decal No. 8

Located on the front of the control shield.

Rated Lift Capacity

XXX lb or XXX kg

800 lbs. 367kg
1000 lbs. 454kg
1300 lbs. 590kg
1600 lbs. 726kg

Decal No. 9

Located on the front of the control shield

TOMMY GATE °

DO'S

- * DO CENTER YOUR LOAD ON PLATFORM.
- * DO CLOSE AND LOCK LIFT IN CLOSED POSITION WHEN NOT IN USE OR UNATTENDED.
- * DO STAND TO THE SIDE OF LIFTGATE WHILE IT IS IN OPERATION.
- * DO READ MAINTENANCE AND SERVICE INFORMATION.
- * DO READ OPERATOR'S INSTRUCTIONS.
- * DO FREQUENTLY CHECK CABLES, CHAINS, AND OTHER COMPONENTS FOR WEAR OR DAMAGE AND REPAIR AS NECESSARY WITH PARTS PROVIDED BY THE ORIGINAL EQUIPMENT MANUFACTURER.
- * DO CHECK ALL SAFETY DEVICES FOR PROPER OPERATION .

DO NOT'S

- * DO NOT RIDE OR PERMIT ANYONE TO RIDE ON LIFT. THE LIFT IS NOT A PERSONNEL OR WHEELCHAIR LIFT.
- * DO NOT MAKE ANY MODIFICATIONS TO THE LIFT OR ITS SAFETY FEATURES.
- * DO NOT ALLOW USE OF LIFT BY A PERSON WHO HAS NOT HAD PROPER TRAINING IN ITS OPERATION.
- * DO NOT TRY TO LIFT OR LOWER MORE THAN THE RATED CAPACITY OF THE LIFT.
- * DO NOT ADD TO OR REMOVE PARTS OF LIFT AS IT WILL VOID YOUR WARRANTY.
- * DO NOT MOVE VEHICLE UNLESS GATE IS IN LATCHED POSITION.
- * DO NOT SHOW CHILDREN OR UNAUTHORIZED PERSONNEL HOW TO OPERATE LIFT.
- * DO NOT LEAVE PLATFORM OPEN, OR UNLATCHED WHEN LIFT IS NOT IN USE OR UNATTENDED. NEVER LEAVE PLATFORM DOWN TO BE USED AS A STEP.

ALL REPAIRS OR REINSTALLATIONS OF TOMMY GATE LIFTS SHOULD BE PERFORMED BY AN AUTHORIZED DISTRIBUTOR THAT IS FAMILIAR WITH ITS OPERATION AND SAFETY FEATURES. ALL REPLACEMENT PARTS MUST BE OF ORIGINAL QUALITY, AND ALL SAFETY AND OPERATIONAL DECALS MUST BE ATTACHED AND LEGIBLE

9981

Decal No. 11

Place in cab in a highly visible area.

OPERATOR'S INSTRUCTIONS

Your Tommy Gate operates off your 12 volt vehicle battery. The vehicle battery powers a 12 VDC motor direct coupled to a hydraulic pump. Flow from the pump extends a cylinder to provide tension to the lift cables that lift the gate platform. A check valve blocks return flow from the cylinder to the pump and a pressure relief valve prevents the gate from being overloaded. The gate platform is lowered by gravity after an electric "release" valve is activated and opened at the pump.

Tommy Gate's electric toggle switch control incorporates a low voltage warning feature. This low voltage feature keeps the user from being stranded because of a dead battery, and keeps the raise solenoid from chattering which prevents welding of the solenoid contacts.

If a low voltage condition occurs, the amber "POWER ON" LED will blink and you will not be able to use the control to operate the gate. In order to operate the gate, you will need to correct the low voltage condition and reset the control. To reset the control, depress the "POWER ON" hidden switch two times, once to "turn it off" and the second time to "turn it on".

The low voltage condition may be caused by - a weak battery, loose or corroded connections, improper ground or bad electrical cables. This condition may be corrected by just starting the vehicle or replacing the battery.

BLINKING AMBER LED INDICATES
LOW VOLTAGE CONDITION

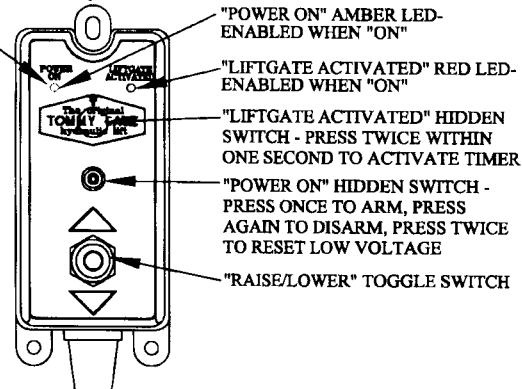

- Step 1.** To open the platform, go to the driver's side of the Tommy Gate and unsecure by lifting the latch off the platform pin and rotate the latch away from the platform. Now go to the passenger side of the Tommy Gate and lift the latch off the platform pin with one hand while holding the top of the platform with your other hand. Now pull the platform open and step away from the platform as it opens. On Lift-n-Dump models open hasps.
- Step 2.** If the gate is on an application with swing out doors, you can open them at this time.
- Step 3.** Be sure to stand clear of the platform and all moving parts when using the lift.

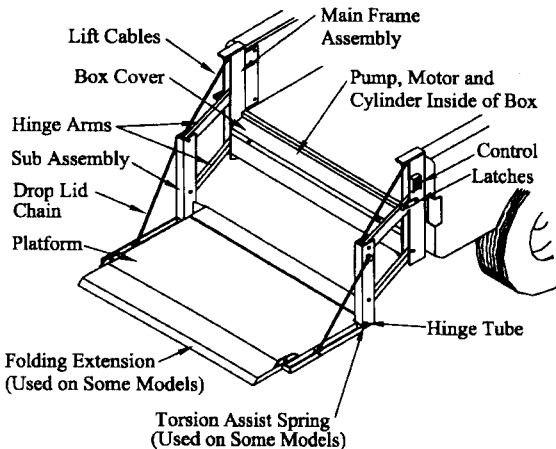

To turn the control power on, press the "POWER ON" hidden switch once, marked with black rings or circles (located between the Tommy Gate logo and the toggle switch). You should see the amber LED "POWER ON" light when the control is armed. To disarm control press again.

To activate the control, press the "LIFTGATE ACTIVATED" hidden switch twice within one second (located under the Tommy Gate logo). You should see the red "LIFTGATE ACTIVATED" light when the control is activated.

To lower the platform, push the toggle switch down. To raise the platform, push the toggle switch up. When you remove pressure from the toggle switch, the operation will stop.

After you have activated the control by pressing the "LIFTGATE ACTIVATED" hidden switch twice within one second (located under the Tommy Gate logo), you have approximately 90 seconds to use the gate. If the gate is not used for approximately 90 seconds, the "LIFTGATE ACTIVATED" timer deactivates the control. If the gate is used during the 90 seconds, the "LIFTGATE ACTIVATED" timer automatically resets for an additional 90 seconds. To reactivate the timer, press the "LIFTGATE ACTIVATED" hidden button twice within one second.

- Step 4.** When the platform is raised to the level of the vehicle's floor and the load is removed from the platform, close the platform and folding extension (if so equipped) by hand. The latch on the passenger's side will secure itself. Go to the driver's side and lift the latch and hook it onto the pin of the platform. On Lift and Dump models, both hasp latches must be secured.
- Step 5.** **Never leave the truck with the platform on the ground, partially raised, or open.** To prevent children or unauthorized personnel from operating the lift, be sure the gate is in the stored position and both the driver's side and passenger's side latches are secured before leaving the truck unattended.
- Step 6.** On Lift and Dump models, to dump through the platform, be sure both upper hasps are secured. Release the lower right latch. Step clear of the lift and release the lower left latch. Stand clear because the dump platform will swing out.
- Step 7.** Inspect the steel lift cables monthly. Anytime they are starting to fray from wear around the pulleys, **be sure to replace them with cables furnished by Tommy Gate Company.**
- Step 8.** The Tommy Gate is designed for material handling only, it is not a personnel lift. Do not ride on the platform and always stand clear of the platform when opening, raising or lowering.
- Step 9.** **Never show children or unauthorized personnel how to operate the gate.**
- Step 10.** Always deactivate control when not in use.

MAINTENANCE AND SERVICE INFORMATION

All installations, re-installations, and repairs of Tommy Gates should be performed by a qualified authorized distributor that is familiar with its operation and safety features. All replacement parts must be of original quality, and all safety and operational decals must be attached. No modifications are allowed to a Tommy Gate product unless authorized by the Engineering Department at Tommy Gate.

As is with any mechanical product, a preventive maintenance program needs to be followed in order to keep it in its best operating condition. Please review this information and if you should have any questions please call 1-800-Lift-Gate (800)543-8428 or (712)647-2050. Please have your model number and serial number available.

The Tommy Gate needs to be serviced every 60 days under normal use (275-325 cycles).

- (A) Inspect steel lift cables, all platform chains or platform cables for any wear or fraying. Replace immediately if either is found.
- (B) Check the oil level in the reservoir. With the liftgate platform at the bottom of its travel, the fluid should be two-thirds full **BE SURE THE CYLINDER IS COMPLETELY COLLAPSED**. Add Tommy Gate winter grade or ISO grade 32 hydraulic oil if needed.
- (C) Check for leaks from the cylinder, hoses, and all fittings (replace or repair if found to be leaking).
- (D) Grease pulley grooves as this will help the cables remain flexible, giving you added service.
- (E) Grease all zerk fittings with ample amount of grease (every 30 days).
- (F) Check for cracks in all welds (repair if needed).
- (G) Replace any worn or missing parts before the liftgate is put back into service.
- (H) If needed, adjust platform latches which are designed to hold the liftgate in a properly stored position.
- (I) Check for wear at all pivot points.

NOTE: Lower the liftgate to the ground to grease the liftgate arms. The grease zerks are located inside the uprights on the arm collars.

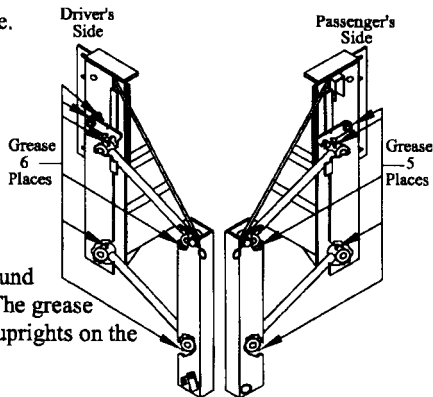



WELDING NOTE !!! DISCONNECT ALL BATTERY CABLES. ALWAYS DISCONNECT THE GROUND CABLE FIRST. ATTACH THE WELDING GROUND TO THE TRUCK RATHER THAN THE LIFTGATE.

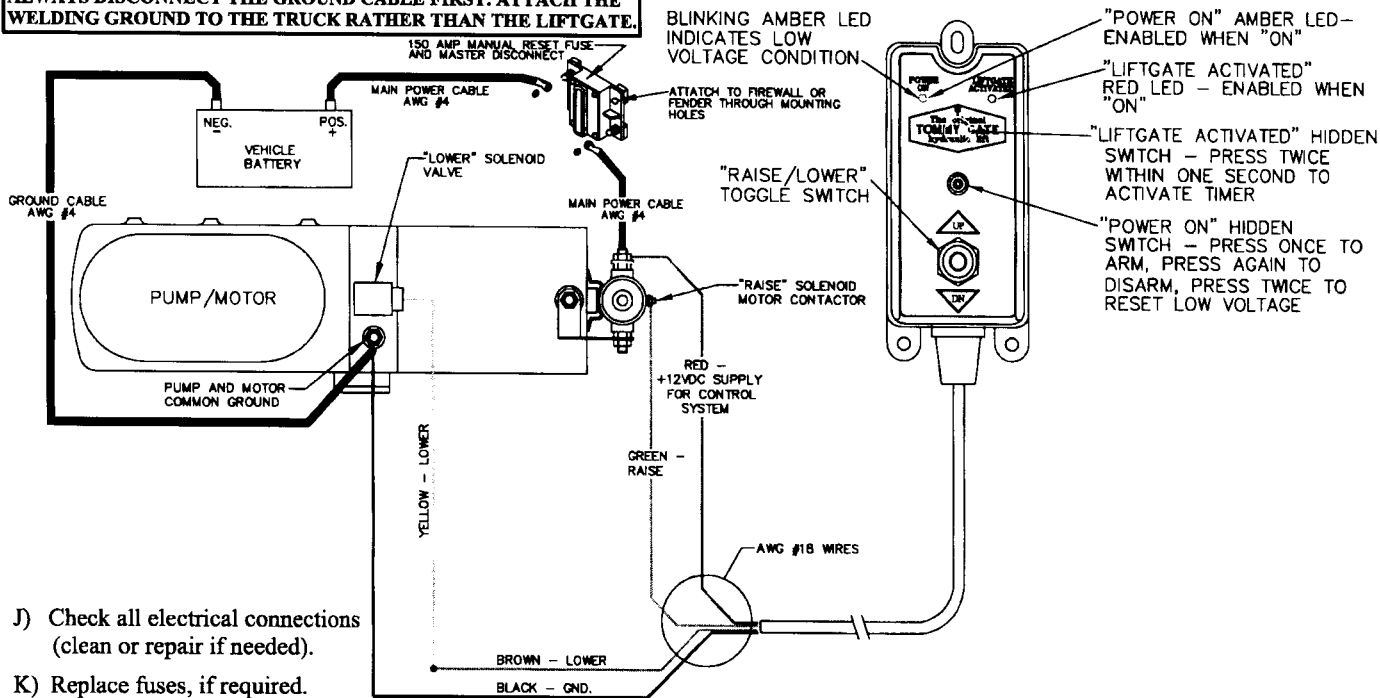

- J) Check all electrical connections (clean or repair if needed).
- K) Replace fuses, if required. Check electric cables for wear or damaged insulation.
- L) Replace or clean safety decals so they are legible.
- M) Check for proper operation of control.

NOTE !!! IF GATES ARE NOT WIRED IN ACCORDANCE WITH THIS DIAGRAM YOUR WARRANTY WILL BE VOID.



PLEASE READ AND FOLLOW ALL DIRECTIONS BEFORE PROCEEDING!!!



TROUBLE SHOOTING - 500, 1000, 1300 & 1600 SERIES

PROBLEM	POSSIBLE CAUSE	REMEDIES
<p>1.) Lift will not operate - "POWER ON" amber LED light does not come on.</p>	<p>a.) Control not armed properly. b.) Poor electrical connection. c.) 3 Amp mini - ATO fuse is blown. d.) Polarity is reversed. e.) Circuit breaker tripped or disengaged. f.) Control brown out.</p>	<p>a.) Turn the power on at the control by pressing the "POWER ON" hidden switch, marked with black rings or circles (located between the Tommy Gate logo and the toggle switch). b.) Check and repair or replace all cables and connections. c.) Replace fuse. d.) Switch positive and negative cables. e.) Check for short, then manually engage circuit breaker. f.) Trip circuit breaker manually for 2 minutes then engage again.</p>
<p>2.) Lift will not operate - "LIFTGATE ACTIVATED" red LED light does not come on.</p>	<p>a.) "POWER ON" amber LED light is blinking. b.) Control not activated properly. c.) Control brown out.</p>	<p>a.) Low voltage condition. Check and repair or replace all cables and connections. b.) Press the "LIFTGATE ACTIVATED" hidden switch twice within one second (located under the Tommy Gate logo). The red "LIFTGATE ACTIVATED" LED light should come on. c.) Trip circuit breaker manually for 2 minutes then engage again.</p>

PROBLEM	POSSIBLE CAUSE	REMEDIES
3.) Lift will not raise or raises slowly - control working properly.	<ul style="list-style-type: none"> a.) Poor electrical connection. b.) Battery charge is low. c.) Release valve stuck partially open or dirty. d.) Release valve needs replacement. e.) "Raise" solenoid not working. 	<ul style="list-style-type: none"> a.) Check power cable and ground cables and all connections. b.) Recharge or replace battery. c.) Raise platform completely and continue to run pump for 5 seconds. d.) Contact Tommy Gate or distributor. e.) Contact Tommy Gate or distributor.
4.) Lift will not raise all the way.	<ul style="list-style-type: none"> a.) Oil level low. b.) Vent plug not installed or dirty. c.) Poor electrical connection. 	<ul style="list-style-type: none"> a.) Check oil and add ISO grade 32 or Tommy Gate winter grade hydraulic oil or equivalent. b.) Check vent plug on pump tank. A red shipping plug is installed at factory. It must be replaced by the metal vented plug. c.) Check power and ground cables and all connections.
5.) Lift settles down slowly with load or no load.	<ul style="list-style-type: none"> a.) Check valve stuck or dirty. b.) Check valve damaged. c.) Hose or fitting leaking. d.) Cylinder seals worn or damaged. e.) Down solenoid sticking partially open. 	<ul style="list-style-type: none"> a.) Raise and lower lift several times to flush out valve. b.) Contact Tommy Gate or distributor. c.) Tighten or replace. d.) Contact Tommy Gate or distributor for repair or replacement. e.) Contact Tommy Gate or distributor for repair or replacement.
6.) Pump or motor noisy.	<ul style="list-style-type: none"> a.) Worn pump, motor or coupling. 	<ul style="list-style-type: none"> a.) Contact Tommy Gate or distributor.

PROBLEM	POSSIBLE CAUSE	REMEDIES
7.) Lift lowers very slowly, especially in cold weather.	<ul style="list-style-type: none"> a.) Cold, thick, oil. b.) Lack of lubrication at hinge arm pins. c.) Pins seized due to lack of lubricant. d.) Kicker springs broken. 	<ul style="list-style-type: none"> a.) Check oil type. Add winter grade Tommy Gate hydraulic oil. b.) Lubricate all zerks. c.) Replace pins. d.) Replace kicker springs.
8.) Lift will not lower.	<ul style="list-style-type: none"> a.) Control not armed and activated - No amber "POWER ON" LED or red "LIFTGATE ACTIVATED" LED light on. b.) Poor electrical connections. c.) 3 Amp Mini - ATO fuse is blown. d.) Lift stuck or sprung, if control is working properly. e.) If control working properly, damaged or non-working release solenoid. 	<ul style="list-style-type: none"> a.) Press the "POWER ON" hidden switch, marked with black rings or circles (located between the Tommy Gate logo and the toggle switch). The amber "POWER ON" LED light should come on. Now press the hidden "LIFTGATE ACTIVATED" switch twice within one second (located under the Tommy Gate logo). The red "LIFTGATE ACTIVATED" LED light should come on. b.) Check and clean or repair all electrical connections. c.) Replace fuses. d.) Apply downward load on platform, pry away upright sides. e.) Contact Tommy Gate or distributor.
9.) Blinking amber "POWER ON" LED.	<ul style="list-style-type: none"> a.) Low voltage condition. b.) Poor grounds or connections. c.) Power connected or reconnected since last use. 	<ul style="list-style-type: none"> a.) Check and clean or repair all electrical connections. Load test battery, then recharge or replace battery, if required. Reset Control. b.) Repair, replace, clean as necessary. c.) Normal, press bullseye once to activate solid "POWER ON" red LED.

WARRANTY GUIDELINES

A. STANDARD WARRANTY

The Tommy Gate Company provides a limited warranty against faulty materials or workmanship. Tommy Gates are guaranteed for one (1) year from the date of user purchase and all pump and motor unit parts are guaranteed for two (2) full years from date of user purchase against faulty materials or workmanship.

All affected parts must be returned to the factory prepaid - with full credit issued for those found to be defective. Warranty replacement parts will be shipped from the factory prepaid.

Labor charges to install warranty replacement parts shall be paid in accordance with Tommy Gate's estimated repair time guide and a flat hourly rate established by Tommy Gate. **DEVIATION FROM THE WARRANTY TIMES LISTED MUST BE AUTHORIZED BY TOMMY GATE COMPANY IN ADVANCE.**

The warranty does not include damage resulting from improper installation procedures. Parts must be installed according to Tommy Gate Company's specifications.

Tommy Gate Company will not pay labor for removing other equipment to gain access to Tommy Gate Equipment. Tommy Gate Company will not pay labor for time on the road to and from a service call.

Tommy Gate Company reserves the right to disallow or reduce claims for parts which have been damaged due to misuse, abuse, accidents or improper shipping; or parts which have been incorrectly or unnecessarily replaced.

The warranty is void if the product has been subject to other than normal use. **THERE ARE NO WARRANTIES, EXPRESS OR IMPLIED, INCLUDING THE WARRANTY OF MERCHANTABILITY OR A WARRANTY OF FITNESS FOR A PARTICULAR PURPOSE EXTENDING BEYOND THAT SET FORTH ABOVE.**

B. WARRANTY CLAIMS HANDLING PROCEDURE:

The following procedures are required when an authorized distributor submits a warranty claim for a defective Tommy Gate part:

1. Before any expense is incurred, but after the problem has been diagnosed, the authorized distributor should contact Tommy Gate Company's Warranty Department to discuss the problem and its correction.
2. If it is determined that the condition is potentially covered by Tommy Gate Company's warranty, the authorized distributor will receive instructions on how to proceed. A decision will be made to either repair or replace the product or part in question.
3. If the product or parts are to be repaired, the authorized distributor will receive a **WARRANTY REQUEST NUMBER**.

4. If the product or parts are to be replaced, the authorized distributor will be instructed to either hold the parts for inspection by a representative, in which case the authorized distributor will receive a **WARRANTY REQUEST NUMBER**, or the authorized distributor will be asked to return the product for inspection to Tommy Gate Company, in which case the authorized distributor will receive a **RETURN GOODS AUTHORIZATION NUMBER**. Under no circumstances are parts to be returned without a **RETURN GOODS AUTHORIZATION NUMBER**.
5. After the repair or replacement work is completed, the authorized distributor will submit the claim to Tommy Gate Company with the following information:
 - a. Tommy Gate Company **WARRANTY REQUEST** and/or **RETURN GOODS AUTHORIZATION NUMBER**.
 - b. Tommy Gate model number.
 - c. Tommy Gate serial number.
 - d. Tommy Gate part number involved and a description of the apparent problem or defect.
 - e. Authorized distributor performing warranty work.
 - f. Person responsible for warranty work (contact).
 - g. Distributor from whom lift gate was purchased.
 - h. Lift gate owner's name, address, and phone number.
 - i. Action taken, cost involved, complete with work orders and parts expense invoices.
6. If defective parts are to be returned to Tommy Gate Company they:
 - a. Must be packaged for each individual warranty return. No multiple warranty claims in the same box.
 - b. Must be returned "freight prepaid" to Tommy Gate Company's location.
 - c. Must be clearly marked with the **RETURN GOODS AUTHORIZATION NUMBER** on the outside of the package.

Warranty claims must be submitted by the Authorized Distributor on behalf of their customer as part of their customer assistance.

Warranty claim acceptance or rejection is based solely upon defective part inspection and a review of the claim date (outlined in step 5 above) as they apply to the requirements of the Tommy Gate Warranty. Claim reimbursement after acceptance is governed by those allowances previously agreed upon between Tommy Gate Company and the Authorized Distributor (as outlined in Steps 1-4 above).

Any warranty claims submitted without a **WARRANTY REQUEST NUMBER** or **RETURN GOODS AUTHORIZATION NUMBER** and the necessary information will be denied.

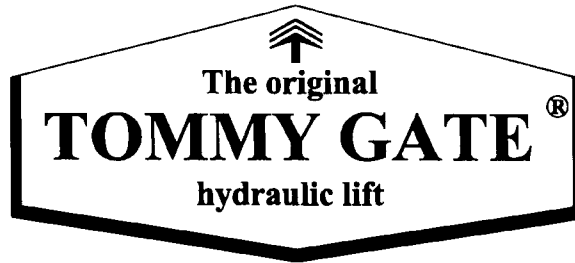

**America Calls Lift Gates
by Our First Name**

Manufacturing Plant:
Bus Brown Drive
Woodbine, Iowa 51579
(800) LIFT-GATE (800) 543-8428
in Iowa Call (712) 647-2050
FAX (712) 647-2417

Corporate Offices:
5112 N. 40th Street
#105
Phoenix, Arizona 85018
(602) 955-2144
FAX (602) 955-3902