

Anthony ATU Tuckunder SF™ Hydraulic Liftgates®



*With Lifetime Adaptor Frame
Warranty Against Rotational Wear*

Lifting Capacities: 1,800 lb. 2,500lb. 3,000 lb. 3,500 lb.



ANTHONY
LIFTGATES, INC.®

Anthony: Industry Leader

Anthony Liftgates has been the driving force in the industry since 1941, producing innovative designs and quality products for trucks of all sizes. Our factory support is unmatched in the industry, providing dealers and their customers coast to coast with prompt delivery of products, parts orders, and custom engineering requests. Looking for a product you can stake your reputation on? Anthony Liftgates offers a wide range of models backed by the best warranty in the business. For performance, dependability, and value, Anthony delivers the complete package for every application!

Hydraulic System

The closed hydraulic system protects against outside contaminants and moisture. The lockable steel pump enclosure



protects components from damage by impact, debris, and weather. Hingeless lid design eliminates corroded hinge problems.

Service-Free™ Bushings — An Anthony First

Used at critical pivot points, these bushings extend pin and



arm life, while eliminating routine lubrication and increasing resale value.

Marine-Duty Control Switch

This switch operates reliably under all types of weather conditions. Heat-shrink wire connections and stainless steel terminal fasteners provide extra



corrosion protection, thus providing uninterrupted service in harsh weather climates.

E-Z Mount™ Installation

All Anthony ATU models are factory assembled, tested, and energized to assure the highest quality performance standards. They ship completely assembled on skids for fast, clean, easy installation; and Anthony's



pre-notched center mark template ensures accurate placement of the floor extension and precise spacing for all welds. E-Z Mount installations provide the fastest installation times of any available models.

Positive Electrical Connections

Anthony's heat-shrink siliconed wire connections seal out moisture. Anti-rotation terminals



insure rugged circuit protection, and stainless steel fasteners resist corrosion.

Low Operating Pressure, Larger-Bore Hydraulic Cylinder

The double-weight hydraulic cylinder allows operation at a lower pressure to increase the



life of the entire hydraulic system, batteries, and electrical components. The chrome-plated piston rod, piston cylinder wear rings, and adjustable gland packing nut further extend Service-Free operation.

Anthony Exclusive, ZLC- Zero Leak Concept™



The use of machined fittings, SAE "O" ring and JIC hydraulic connections, along with factory installed -70° low pour hydraulic fluid, mean you'll have long, trouble-free service with no aggravating and costly leaks.

Quality Standard Features:

Dual Driver Step Stirrups*

Provide convenient assistance for mounting and dismounting on left or right of truck.

Pressure Compensated Flow Valve

Provides constant and controlled lowering speed of the platform, loaded or unloaded, and prevents platform from "free-fall" under certain hydraulic failures.

Chrome Plated Piston Rod

Keeps exposed surface free from rust and contamination to protect seals and extend cylinder life.

Piston Cylinder Wear Rings

Prevent scoring by maintaining piston/cylinder wall tolerances.

Adjustable Gland Packing Nut on Cylinder

Allows adjustment of piston rod seal, extending life of the seal.

Relief Valve

Prevents overloading during lifting cycle.

Low Operating Pressure

Extends service life of power unit, hoses, cylinder seals and battery.

3/16" Formed Diamond Tread Floor Extension

Provides rugged and attractive surface.

1/8" Industrial Diamond Tread Platform

Provides the largest standard platform in the industry.

Platform Roller Wheel Opener

Prevents metal-on-metal damage and provides smooth folding and unfolding.

Spring-Assist Platform

Dual torsion springs provide easy opening and closing. (Single spring on lowboy models.)

Heavy-Duty Sandwiched Hinge Plate

Maintains platform stability under heavy load conditions.

Powder Coated Finish

Provides attractive, long-life protective finish.

Adaptor Frame Mechanism—Lifetime Warranty Against Rotational Wear Failure

Together with our 3+2 warranty on all parts and labor.

Heavy-Duty 1/2" Steel Dock Bumpers

With rubber bumper pads to withstand "dock shock".

Circuit Breaker - 150 Amp.

Protects truck wiring and power system in the event of a "dead short".

Cab Cut-Off Switch

Protects liftgate from unauthorized use.

Yellow Di-Chromate Plated Pins

Used at all pivot points, these pins provide long-life protection from rust, road salt, and moisture.

* NOTICE: Some models of Anthony Liftgates may be provided with step devices to assist the ingress and egress of the truck or trailer rear. These devices are NOT to be considered ALL INCLUSIVE of any requirements or guidelines regarding proper ingress and egress of trucks and trailers. These items are provided as only an added feature for installers to help simplify the meeting of possible ingress and egress requirements. As there are many variables in truck sizes and shapes, it is the installer's responsibility to determine proper ingress and egress requirements, such as steps and hand grips, for each vehicle receiving an Anthony liftgate.

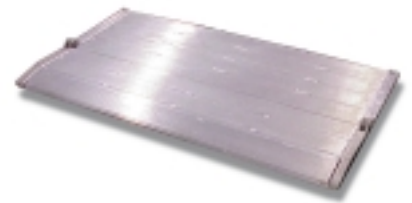

Optional 80" x 45" + 6" Aluminum Platform, including Power-Down operation



Recessed Toggle Switch (optional)



Optional 5-ton Pintle Hook Bracket



Optional 80" x 42" + 12" Steel Platform with 12" Aluminum Retention Ramp



Easy access and highly visible, heavy-duty Latch Pin Assembly positively secures gate in closed position. This Anthony *standard* feature is the strongest and most visible latch in the industry

Available Models, Platforms and Capacities

MODEL	Lifting Capacity (lbs.)	Bed Height Min-Max	Platform Load Area and Ramp	Shipping Wt. (lbs.)
ATU-1800-SF	1,800	42" -57"	80" x 38"+5"	903
ATU-2500-SF	2,500	42" -57"	80" x 38"+5"	928
ATU-3000-SF	3,000	42" -57"	80" x 38"+5"	953
ATU-3500-SF	3,500	42" -57"	80" x 38"+5"	953
Power Down Models				
ATU-1800PD-SF	1,800	42" -57"	80" x 38"+5"	903
ATU-2500PD-SF	2,500	42" -57"	80" x 38"+5"	928
ATU-3000PD-SF	3,000	42" -57"	80" x 38"+5"	953
ATU-3500PD-SF	3,500	42" -57"	80" x 38"+5"	953
Aluminum Platform Models				
ATU-1800A-SF	1,800	45" -57"	80" x 45"+6"	766
ATU-2500A-SF	2,500	45" -57"	80" x 45"+6"	791
Lowboy Models				
ATU-1800LB-SF	1,800	36" -57"	72" x 32"+5"	880
ATU-2500LB-SF	2,500	36" -57"	72" x 32"+5"	926

All models shipped with standard ramp ride platform.
Specifications subject to change without notice.

Options

- Hand-held control (on coiled cord) with plug and socket
- Wireless hand-held remote control
- Third step add-on extension for bumpers
- Street-side control
- Flush-mount control inside van
- Lift-alert audible warning system
- Steel guard for toggle switch control box
- Recessed toggle switches
- 5 ton pintle hook bracket
- P.T.O. drive
- Custom platforms and applications
- 102" wide floor extension
- 80" x 42" + 4" ramp platform
- 80" x 42" + 12" aluminum retention ramp
- 1/4" Heavy-duty floor extension

Mounting Requirements

A Bed Height Adapter Frame	B Bed to top of Clearance	C Mounting Plate
36" - 41"	15 3/4"	29"
42" - 49"	19"	24 1/4"
50" - 51"	20"	23 3/4"
52" - 53"	21"	23 1/4"
54" - 55"	22"	22 5/8"
56" - 57"	23"	22 1/2"

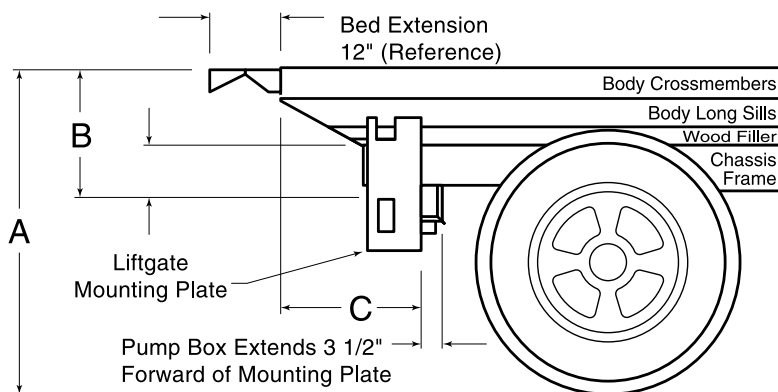

ANTHONY LIFTGATES, INC.®

Anthony Liftgates, Inc.
1037 W. Howard Street
P.O. Box 615
Pontiac, IL 61764-0615
Phone: 815.842.3383
Fax: 815.844.3612
Toll Free: 800.482.0003
www.anthonyliftgates.com