



# Installation Manual

## LHLP5500G Hide-A-Way<sup>®</sup>

### Tuckunder Style



**LEYMAN MANUFACTURING CORPORATION**

10900 Kenwood Road  
Cincinnati, OH 45242

1-866-LEYMAN-1 · 1-866-539-6261 · 513-891-6210

Fax 513-891-4761

[www.leymanlift.com](http://www.leymanlift.com)

[sales@leymanlift.com](mailto:sales@leymanlift.com)

LML00345-05/01/15

# TABLE OF CONTENTS

---

Product Information	2
Installation Data on LHLP5500G	3
Dimensions	4
Installation without Bed Extension	5
Weld Extension Rear Sill & Braces	6
Mounting Gate	7
Secure the Trunion Tube	8
Power Unit Alternate Mounting	9 – 10
Adjusting the Radius Arm	11
Install the ICC Bumper / Optional Adjustable Steps	12 - 13
Install Electric's	14
Finish Weld Mounting Plates / Adjust Platform Slope	15
Install Transfer Safety Latch / Touch-Up Painting and Re-Painting	16
Installing Safety Decals	17
Add grease to pivot joints	18
Electric/Hydraulic Diagrams	19
Maintenance Minder 2 <sup>®</sup> Overview	20
Maintenance Minder2 <sup>®</sup> Controller Menus	21
Maintenance Minder2 <sup>®</sup> Controller Menus	22
Walk Around Push Button Option	23
Emergency Hand Pump	24
Recommended Oils, Lubrication, Specifications	25
Final Inspection Sheet	26
Notes	27

# PRODUCT INFORMATION

---

## OVERVIEW OF INSTALLATION

1. Weld extension to vehicle
2. Raise lift arms and platform
3. Tack weld mounting plates to chassis frame and trunion tube
4. Install power unit box
5. Install radius arm and ICC bumper
6. Install electric's
7. Finish weld and adjust platform
8. Install safety stickers

## TAIL LIFT: LHLP 5500G

Tail Lift equipped with bi-fold platform

Load Capacity: 5500 lbs

Platform size available: 86" wide x 60" deep

The platform folding/unfolding is aided by springs

Main control: Toggle switch panel

**WARNING:** SINCE THIS GATE HAS POLYMER GREASELESS BEARINGS IN SOME OF ITS PIVOT POINTS, (TENSION ARM, COMPRESSION ARM AND CYLINDER PIVOTS) ATTACH GROUND WIRE CLOSE TO WHERE YOU ARE WELDING OR YOU WILL DAMAGE CYLINDER AND OTHER COMPONENTS.

# INSTALLATION DATA ON LHLP 5500G

**A** = From top of bed height to top of trunion tube

**B** = From rear edge of bed to front edge of mounting plate

**B1** = From rear edge of bed to lower front edge of mounting plate

**D** = From top of the trunion tube to the ground

**E** = From bed height to the ground

**F** = From the ground to the rear sill (Laden)

E	A	B	B1	D	F min.
60" MAX.	25"	34-13/16"	36-5/16"	35"	45"
56"	24"	35-7/16"	36-15/16"	32"	45"
52"	22"	36-11/16"	38-3/16"	30"	45"
48"	20"	37-3/4"	39-1/4"	28"	45"

MAX DIM.	TRUCK	TRAILER
X	24"	12"
Y	30"	22"

**E max** = Bed Height (Unladen)

**E min** = Bed Height (Laden)

A and B are variable dimensions. Maintain the A and B dimensions between range according with E dimension of your truck or trailer.

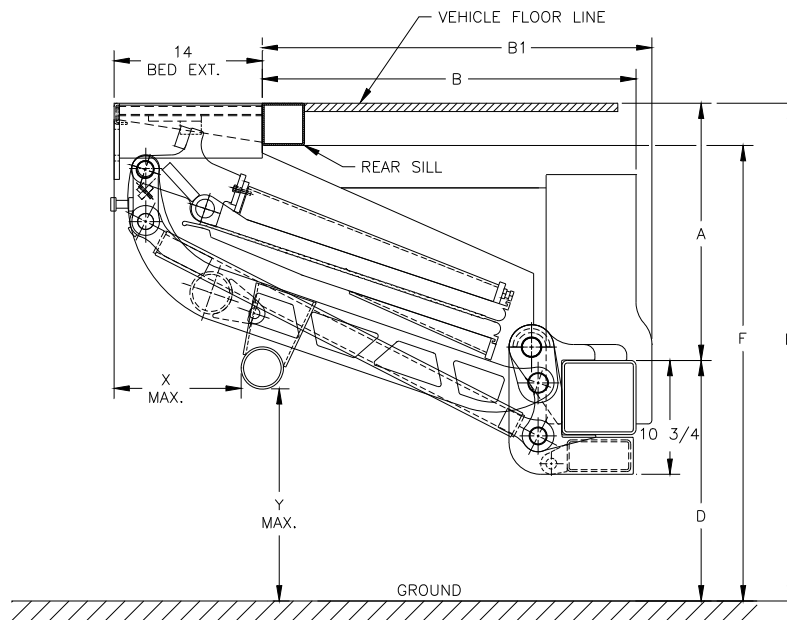

# DIMENSIONS

---

<b>L</b>	<b>MINIMUM: 26 in</b>
	<b>MAXIMUM: 45 in</b>

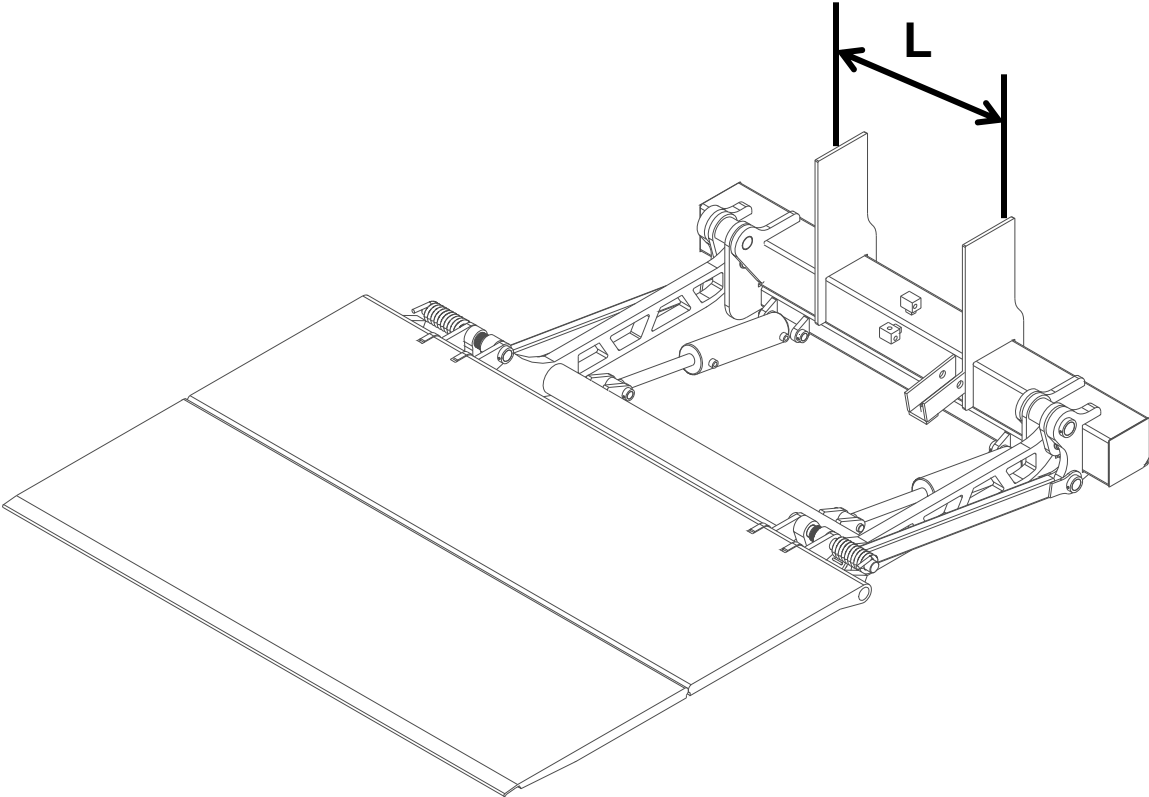

# INSTALLATION WITHOUT BED EXTENSION

The standard installation includes a Bed Extension. If it is necessary to install without the Bed Extension, the rear sill must be notched per the diagram below. Notching must be a minimum of 8-1/2" deep (toward front of the vehicle). Sides and tops of notches should be boxed in for reinforcement. Be sure to add the 14" standard Bed Extension depth to the "B" and "B1" dimensions when planning this type of installation.

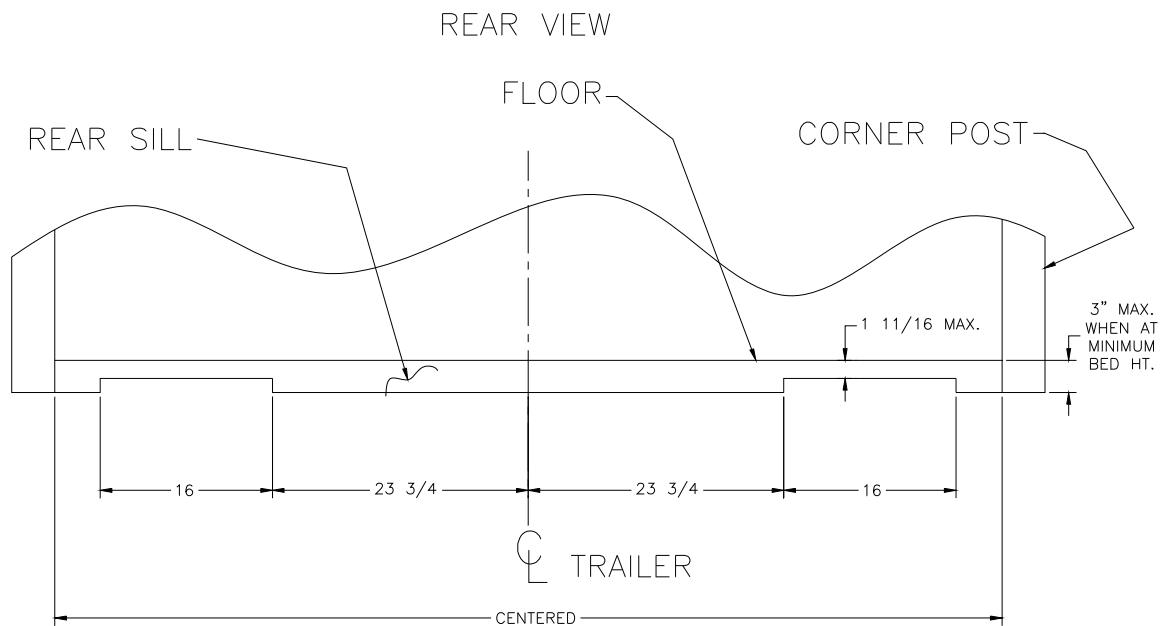

Leyman also offers a Threshold Tube (Option 194) for the LHL45/55 series. It should be installed in the body during the body manufacturing cycle. The Threshold Tube contains all the cutouts required by the gate. Adequate supports must be run between the Threshold Tube and the chassis, since the Threshold Tube functions as the gate "UP" stop.

# WELD EXTENSION TO REAR SILL

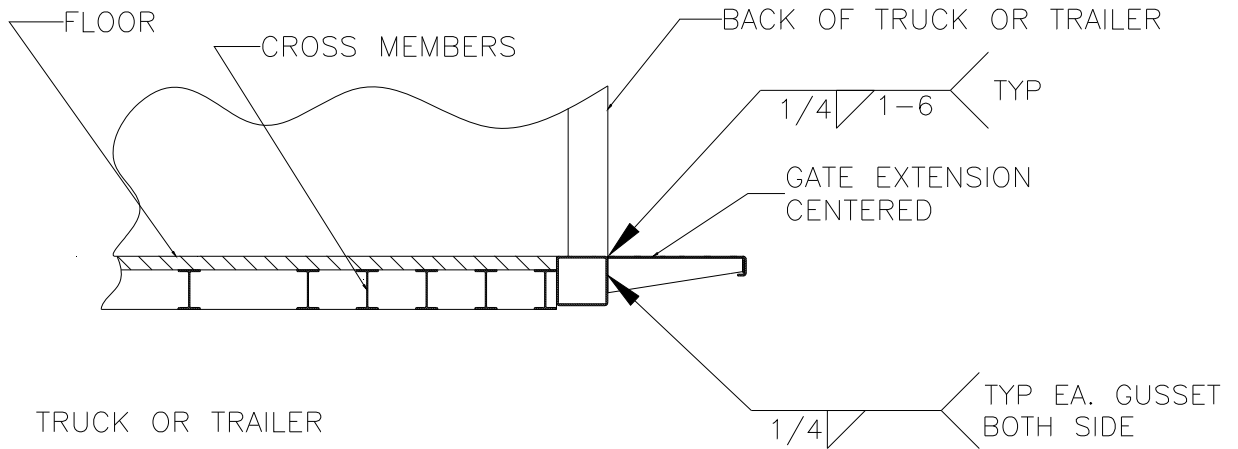

# WELD ON BRACES

GUSSETS OR CHANNELS MUST BE INSTALLED TO REINFORCE BED EXTENSION AND DOCK BUMPERS. REINFORCING CHANNELS ARE SUPPLIED WHEN OPTIONAL HEAVY-DUTY STEPS ARE FURNISHED BY LEYMAN.

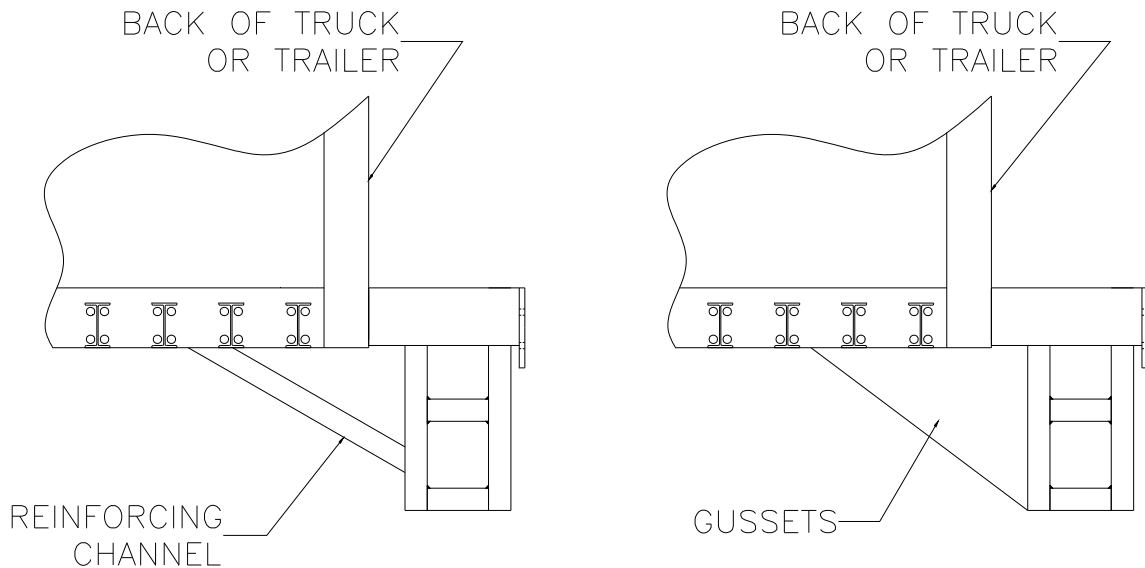

# MOUNTING GATE

---

Remove the existing ICC bumper, lights and wiring where necessary. Platform has been assembled to lifting arms at the factory. It is recommended the gate be installed this way, without the use of a mounting tool.

First remove the platform torsion springs by removing the U-bolt and slide each spring off the pins. Springs on the LEFT and RIGHT sides are different, and must be re-assembled later on the correct side.

Unfold the primary platform, but leave the secondary platform folded on top of the primary. **TEMPORARILY CLAMP THE TILT TUBE TO THE TRUNION WHEN MOUNTING THE GATE TO ASSURE CORRECT ALIGNMENT.** Then securely clamp the platform to the forks of a lift truck so primary platform can be raised to bed height. Primary platform must be even with Bed Extension across entire length, and spaced  $\frac{1}{4}$ " away from the Bed Extension using shims. See diagram below.

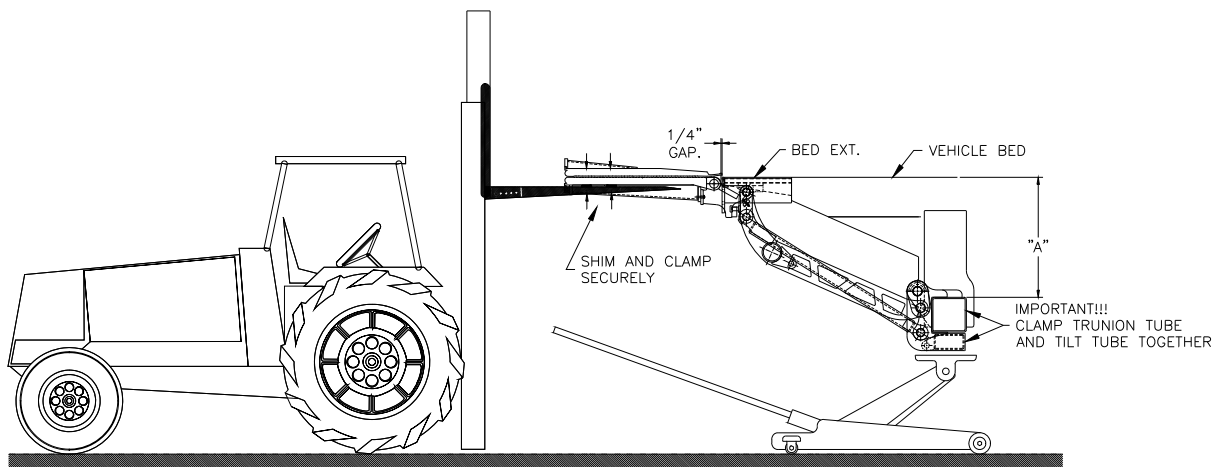

Next raise the gate Trunion Tube using one floor jack in the center. Hold the "A" dimension in the range given on Page 3. The face of the Trunion Tube must be square to the vehicle bed and the primary platform must be even with the Bed Extension across the entire length.



# SECURE THE TRUNION TUBE

---

Tack weld the Mounting Plates (2) to the Trunion Tube (1) and truck frame. Welds must be strong enough to safely support and operate the gate without a load.

If mounting to a trailer, you will have to fabricate mounting rails and supports. Mounting rails must be cross-braced and rigid, and be welded to at least three (3) trailer cross-members. An optional trailer Quick Mount Kit is available. **CAUTION! Trailer slide rails for the tandem wheels are NOT usually suitable for supporting a lift gate. We recommend using a Quick Mount Kit attached to the cross members.**

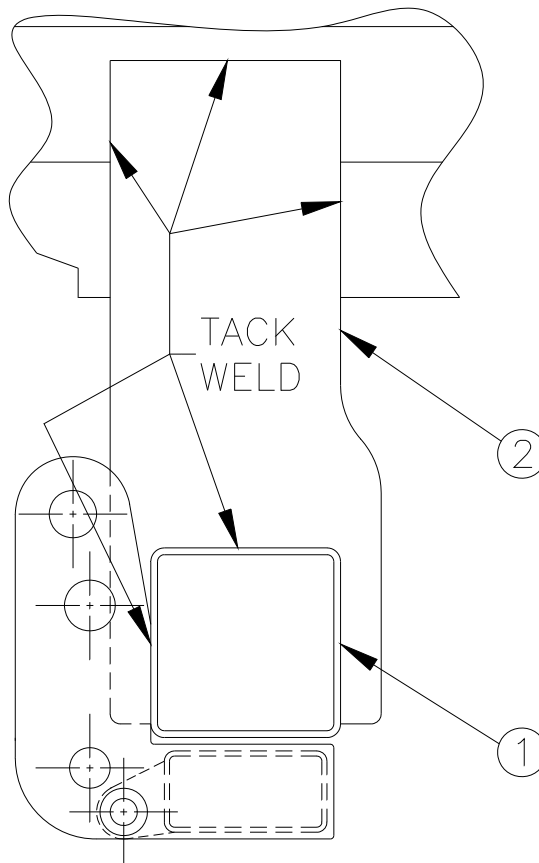

# POWER UNIT BOX ALTERNATE MOUNTING

The gate is shipped with the power unit preinstalled directly on the gate. If desired, the power unit can be relocated to a remote location off of the gate. Longer hoses may be required if moving the power unit.

Determine a location for the power unit box on the curbside of the vehicle. The power unit box is designed to mount directly to the vehicle cross members. Then connect the hydraulic hoses between the gate and the power unit. The hose from the fixed end of the lift cylinders connects to the port labeled "C1" on the power unit. The hose from the rod side of the cylinders connects to the port labeled "C2" on the power unit.

Temporarily connect a 12 volt battery to the circuit breaker in the power unit and fill the tank to within 1" from the top with recommended hydraulic oil. The 5/16" hex head cap screw near the lower front face of the pump block must be used as a ground connection.

Remove the forklift truck from the platform. Lower the lifting arms, then use the lift truck to carefully fold the platform to the vertical position. Reassemble and clamp both torsion springs in place. Now completely unfold platform and verify platform edge meets the bed extension correctly. With an empty platform, the gate must be in POWER DOWN mode for the auto-tilt function to work at the ground. After operating the gate several times, recheck oil level with the gate on the ground. Fill tank to within 1" from the top.

## Install Hydraulic Hoses

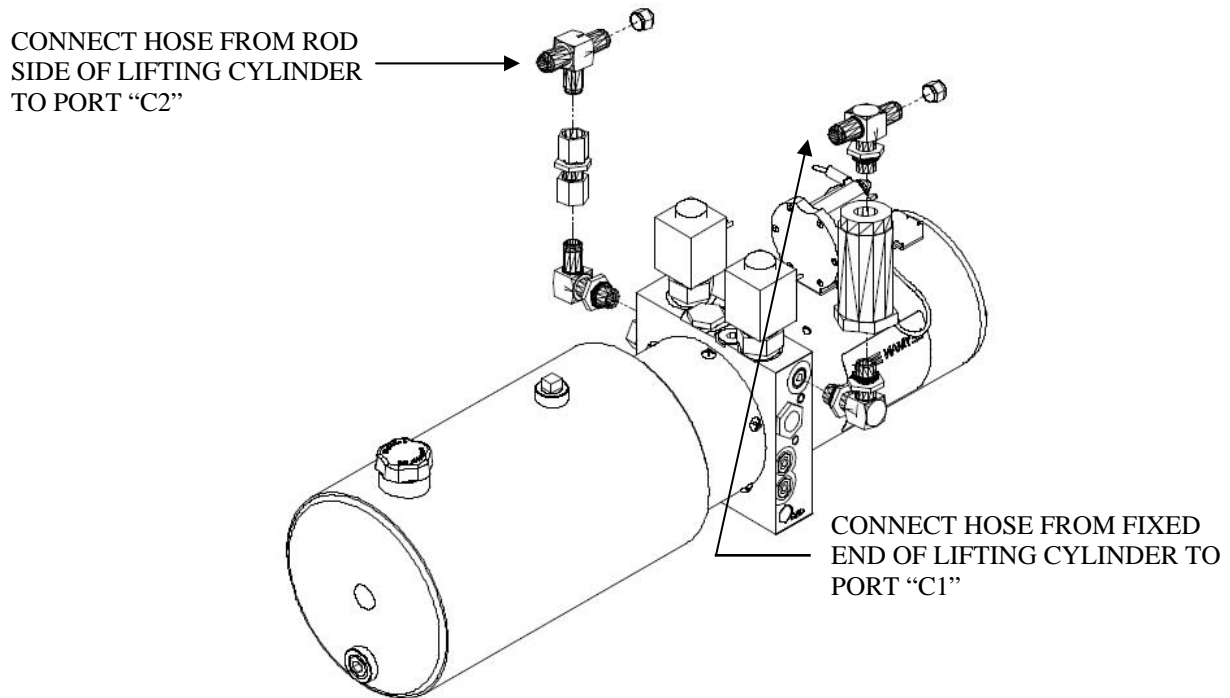

# INSTALL POWER UNIT BOX (Continuation)

## Installation of Hydraulic Hoses when unit has hand pump

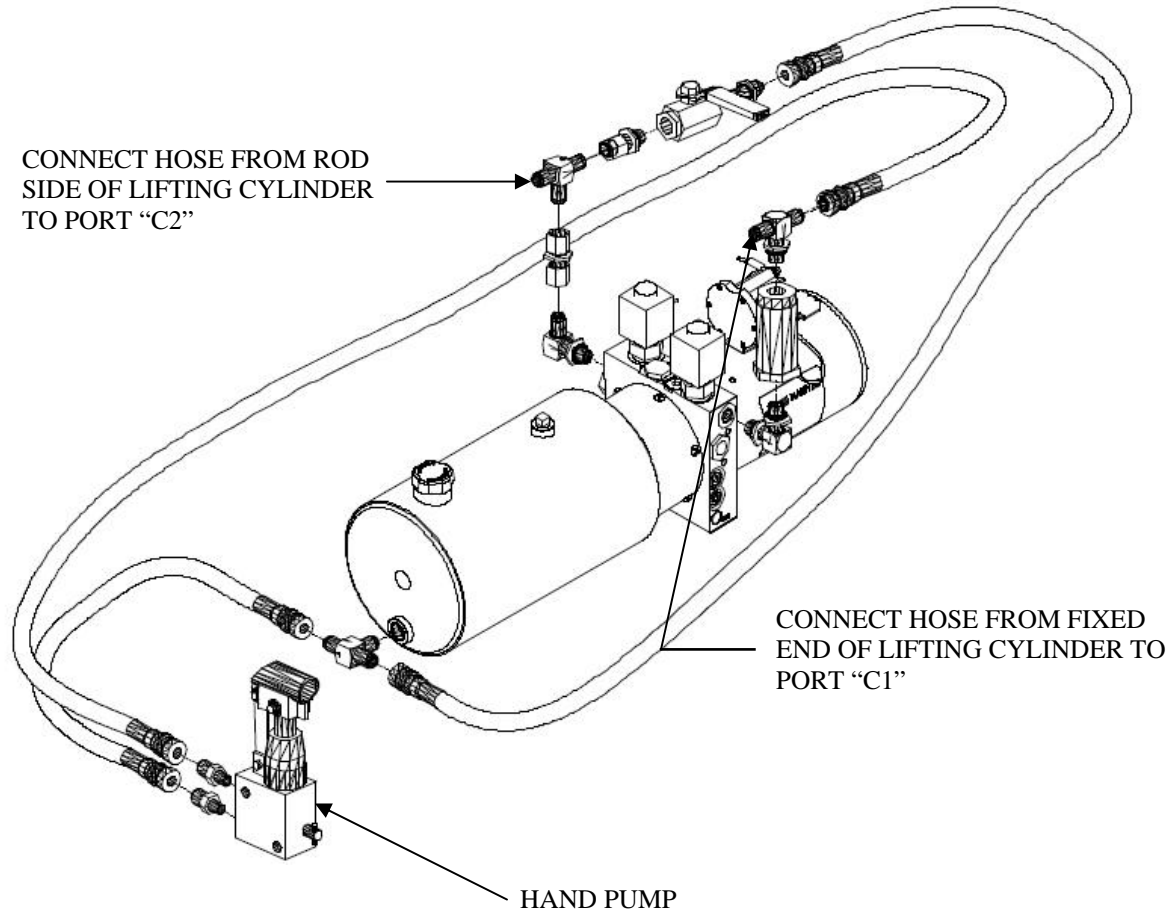

# ADJUSTING THE RADIUS ARM

Gate should come with the Radius Arm welded at the proper length and mounted to the Radius Arm Bracket located on the Trunion Tube. Check Radius Arm length using the sketch below to verify it has been supplied correctly. Radius Arm must clear the round tube that goes across the Tension Arm, as the Tension Arm rotates up and down.

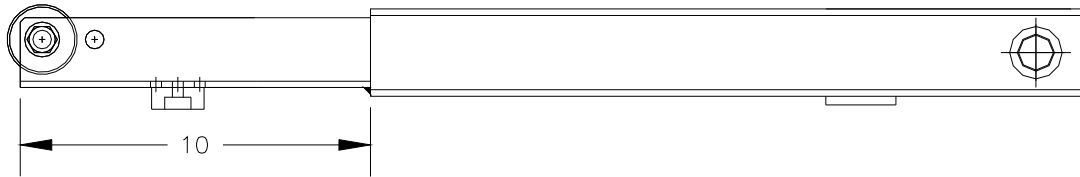

The Radius Arm must be adjusted so that it unfolds the platform as the lifting arms drop to the ground. PLATFORM SHOULD BE NEAR VERTICAL, BUT STILL SLIGHTLY TILTED TOWARD FRONT OF VEHICLE, WHEN LIFTING ARMS ARE ON THE GROUND. Adjusting screw and locking nut location is noted in sketch below.

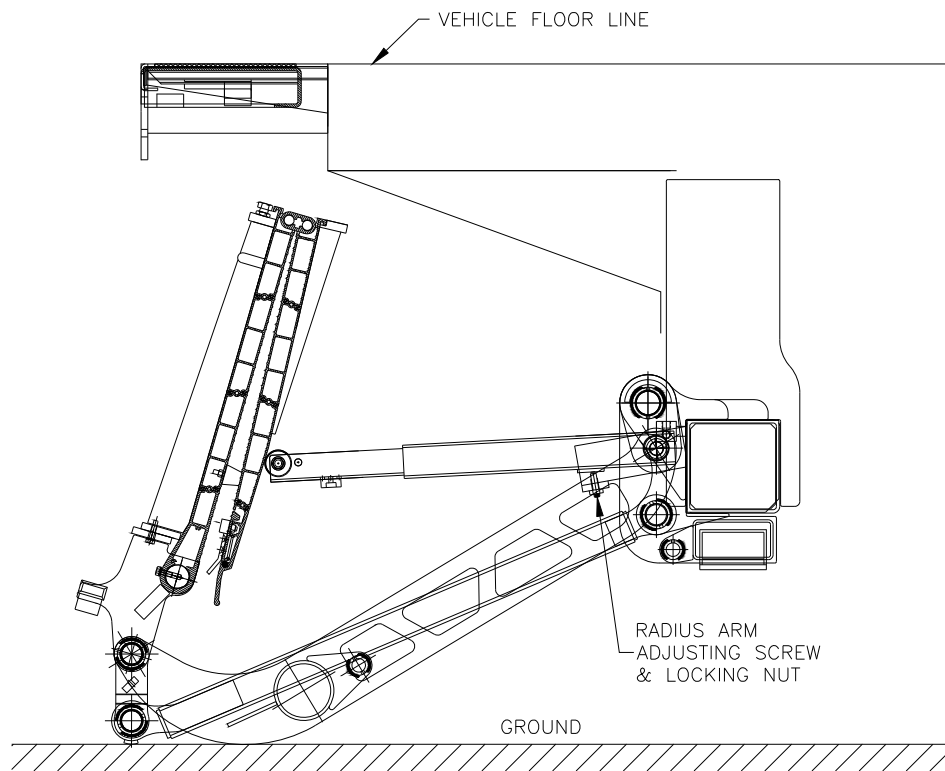

The higher the Radius Arm is adjusted, the slower the platform will fold, and more clearance at the frame rails will be required. But if the platform leans too much toward the front of the vehicle with the lifting arms on the ground, it will be harder to unfold. Radius Arm will pivot up when gate is folded, once the optional ICC bumper is installed. Ground clearance for the Radius Arm is not an issue.

# INSTALL ICC BUMPER

---

The ICC bumper is an option. Follow the 12” and 22” maximum dimensions for trailers, or the 24” and 30” dimensions for trucks as shown on page 3. Bumper support brackets fit on the inside face of the Tension Arms. Support bracket must be trimmed off so the bracket edge is about ½” below the top edge of the Tension Arm.

Tack weld ICC bumper in place initially. Operate gate to check the ground clearance before final welding bumper brackets. Bumper tube should clear the ground by several inches when lifting arms are on the ground. Brackets must be continuously welded to Tension Arms with 3/16” fillet weld at all points of contact.

Observe contact between Radius Arm and bumper tube when lifting gear goes up. Adjust rubber bumper on Radius Arm to a different mounting hole, if necessary.

## INSTALLING OPTIONAL ADJUSTABLE STEPS

---

General method:

1. Measure bed height UNLADEN.
2. Refer to the chart that covers a range of bed heights. Use the corresponding line in the chart that your measurement most closely matches to determine assembly dimensions. Curb side view is shown. Driver’s side view is a mirror image.
3. Trim the lower portion of the Step Mounting Tubes, if required. Use a method that generates minimal heat so paint damage is reduced. An Extreme Shield Touch-Up Kit is provided to re-paint ends.
4. Assemble Step Rung Assembly to Step Mounting Tubes using the appropriate holes referenced in the chart. Leave hardware loose. Then bolt Step Mounting Tubes to Bed Extension using pre-drilled holes. Verify distance from top step to Bed Extension. Enough hardware was shipped to cover all possible cases, so not all hardware may be used for your case.
5. Assemble Step Gusset as shown. C-channel will need to be trimmed at top end. Any extra materials needed to anchor top end of gusset to vehicle is the installer’s responsibility. Tighten all hardware.

The following parts are included in the kit.

Index	Req'd	Part No.	Description	Mat'l Size
1	4	BP-713-103	STEP MOUNTING TUBE	
2	2	BA-713-104	STEP RUNG ASSEMBLY	
3	1	BA-802-194	STEP GUSSET - RH	
4	12	P11061	HEX HD CAP SCREW	3/8-16 X 3
5	8	P11037	HEX HD CAP SCREW	3/8-16 X 3-1/4
6	4	P11060	HEX HD CAP SCREW	3/8-16 X 3-1/2
7	4	P26501	FLAT WASHER	3/8 STD
8	28	P26523	FLAT WASHER	3/8 HEAVY
9	20	P23501	LOCK NUT	3/8-16
10	1	BA-802-203	STEP GUSSET - LH	

# LHLP 45/55

BED HT.	DIM "A"	DIM "C"	TRIM ITEM 1	GROUND CLEARANCE	RUNGS USED	COVER PLT REQ'D	ASSEMBLY IN HOLE #
60 - 58.06	24.00-22.06	24.00	NO	22.19 - 20.25	2	NO	1 & 2
58 - 56.06	24.00-22.06	22.00	NO	22.19 - 20.25	2	NO	2 & 3
56 - 54.06	24.00-22.06	20.00	NO	22.19 - 20.25	2	NO	3 & 4
54 - 52.06	24.00-22.06	18.00	NO	22.19 - 20.25	2	NO	4 & 5
52 - 50.06	24.00-22.06	16.00	NO	22.19 - 20.25	2	NO	5 & 6
50 - 48.00	24.00-22.00	14.00	NO	22.19 - 20.19	2	NO	6 & 7

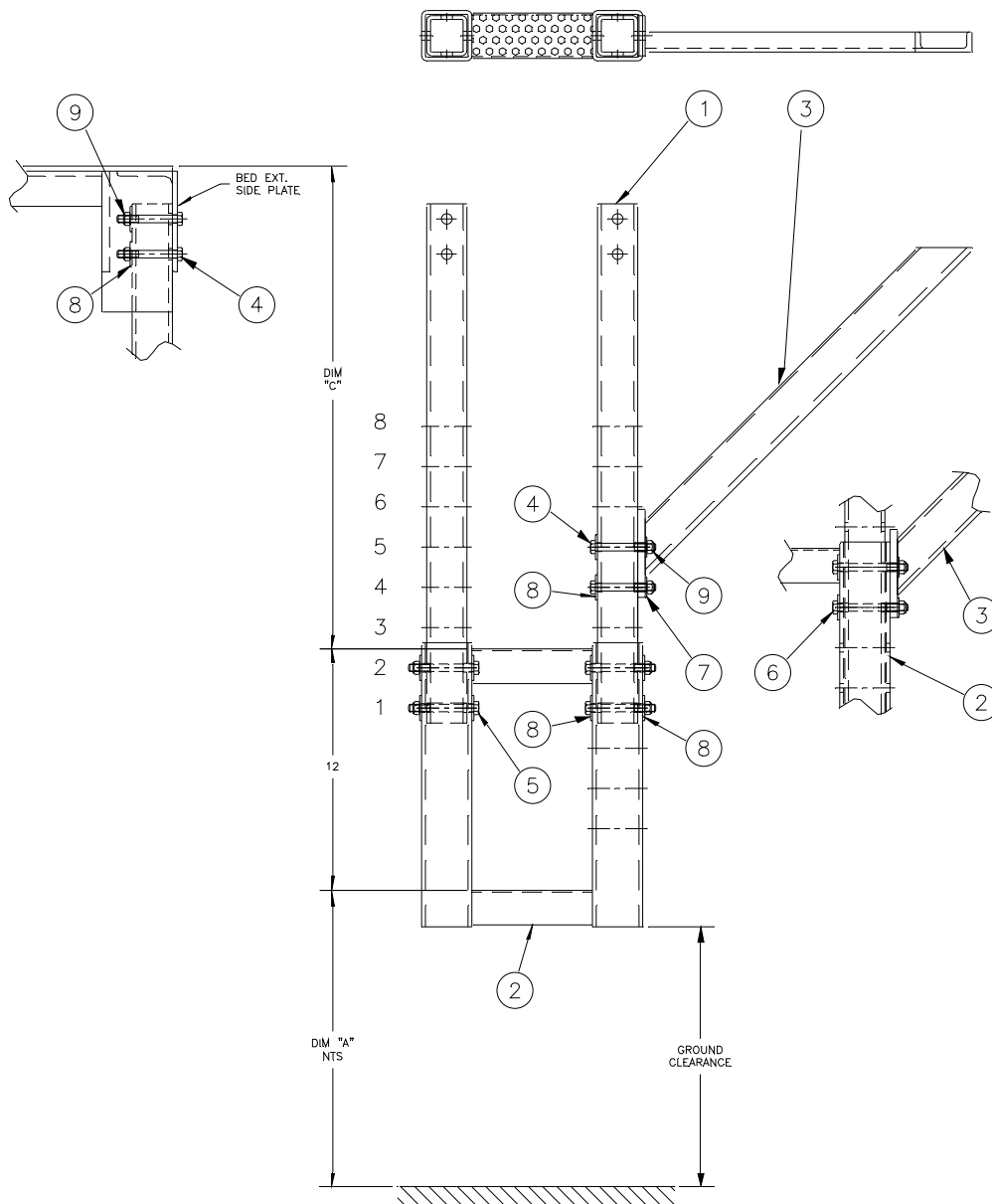

# INSTALL ELECTRICS

---

Mount the pre-wired switch box unit on the curbside corner post. Choose a height that allows the switch to be safely used from the ground and the vehicle bed. Cable must be secured by loom clamps. Cable passes through slot in power unit enclosure near door. Coil and securely tie excess cable inside enclosure. Be sure grommet is in slot at enclosure side wall. Connect fork terminals to terminal strip, matching colors.

Run positive power line through cord grip and connect to battery post on start solenoid. Leyman always recommends using a separate battery (or batteries) to operate the lift gate for trailer applications. Battery recommendations are given on page 24. Leyman also recommends optional circuit breaker to protect power line at the battery.

It is important that the power unit be grounded for reliable operation. A ground stud is provided at the bottom of the power unit enclosure. Run the 4-gauge cable provided through the other cord grip. Crimp connectors and heat shrink tube on each end. Attach one end to the power unit box ground stud and the other to a ground stud on the vehicle.

If the unit has a Hand Held Pushbutton (optional), install per diagram on page 22.

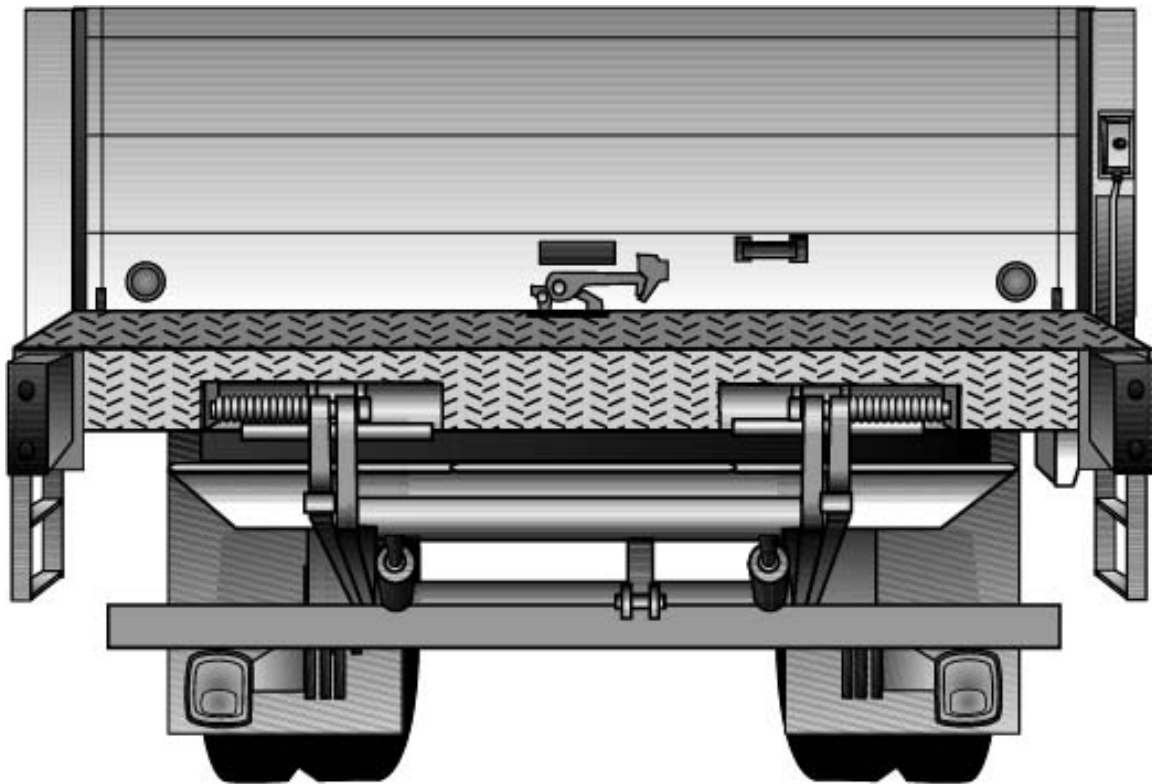

# FINISH WELD MOUNTING PLATES

Operate gate one more time to verify correct operation. Then finish weld both mounting plates to Trunion Tube and chassis frame.

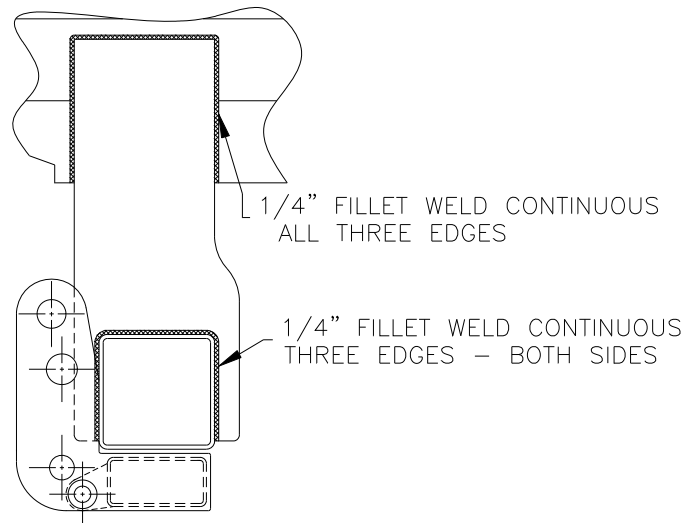

## CHECK and ADJUST PLATFORM SLOPE:

Open the platform and move it to vehicle floor height. First check and adjust the Secondary Platform Support Screws. See sketch below. Screws must be contacting the supports with the Secondary Platform projecting straight and even with the Primary. Use a straight edge to check.

Then adjust the slope of the entire platform using Screws and Jam Nuts (Item 1) on both sides, such that the unloaded platform slopes about 1-1/2" across the 60" depth. After finding the right position, lock the jam nuts on the adjusting screws. **NOTE:** The screws (1) must be adjusted so they push on the platform supports simultaneously!!!.

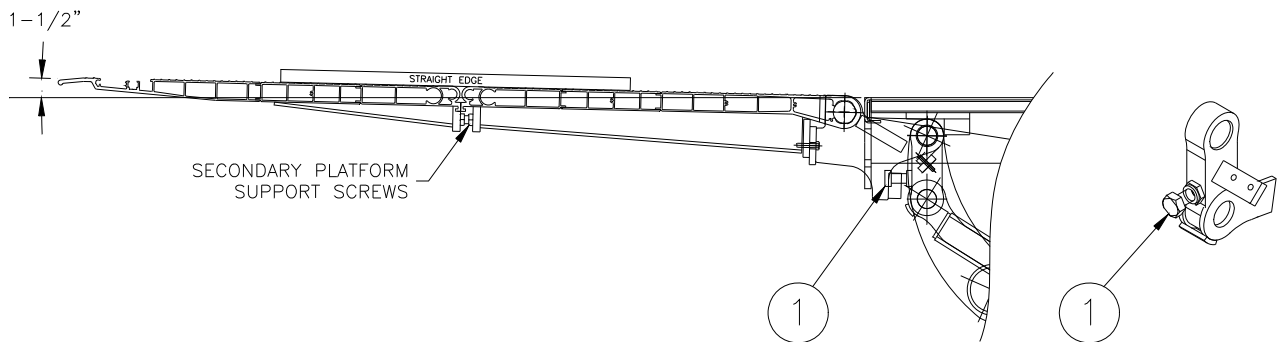



# INSTALL TRANSIT SAFETY LATCH

Weld Safety Latch to inside face of curbside Tension Arm. Be sure Safety Latch does not interfere with Platform Hinge Bracket in the unfolded position. Place gate in the transit (stored) position. Locate steel plate on the inside face of the angle on front of Bed Extension. Determine how many links will be required and cut chain. Then weld chain to the plate and angle as shown. Top chain link must be welded as shown (in view at right) to allow clearance for folding/unfolding. Chain must have some slack in order to snap into Safety Latch.

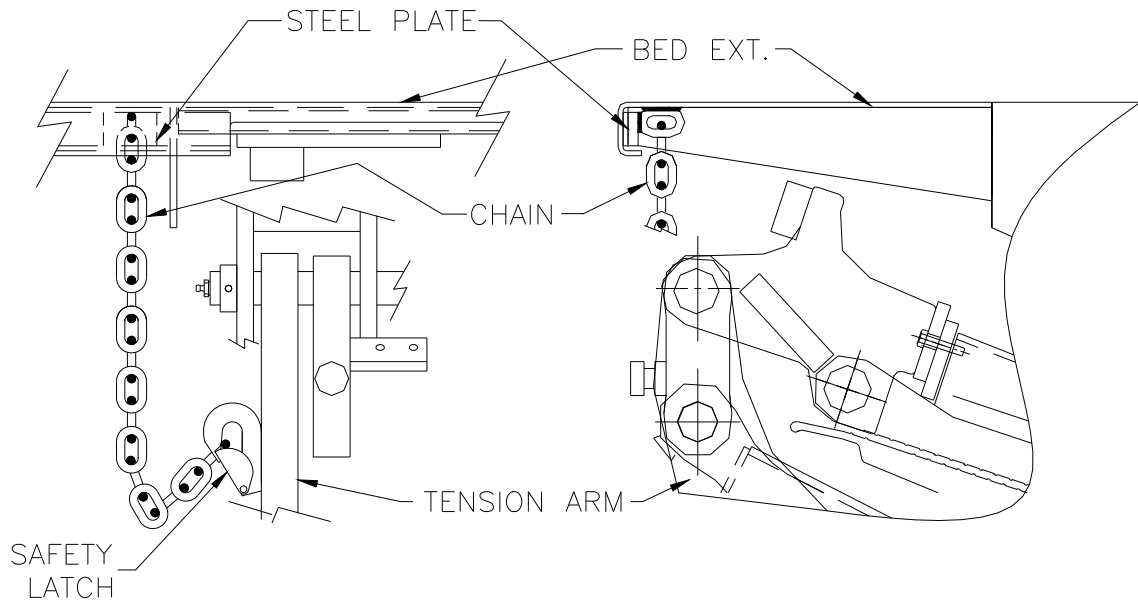

## **TOUCH-UP PAINTING and RE-PAINTING:**

Lift gates are painted with Leyman Extreme Shield<sup>®</sup> at the factory and **MUST** be touched up using the Extreme Shield<sup>®</sup> kit provided. Follow directions on label.

The entire lift gate can be top coated with alkyds, epoxies, or urethanes, if desired. **IMPORTANT!** Cylinder rods must be carefully protected during painting.

# INSTALLING SAFETY DECALS

## IMPORTANT!

All decals should be positioned so they can be seen with the LHL5500G in both the operating and stored positions. Decals must NEVER be covered by components or elements of the vehicle (hooks, locks, cloths, etc.).

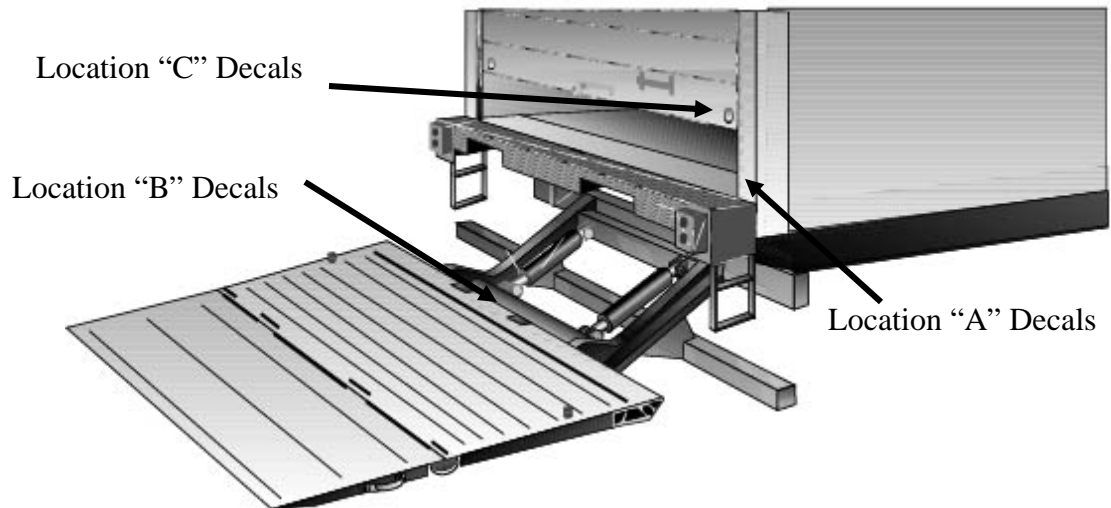

### Location "A"

DESCRIPTION	DIMENSIONS	PART #
Urgent Warning	4 1/2" x 4 1/2"	P55199
After using Lift Gate	4" x 2"	P55201
READ & UNDERSTAND	4" X 3"	P55203
LHLP Operation Instructions	6" x 3"	P55329
CAUTION Maximum Load 5500 lbs	4" x 7"	P55321

### Location "B", on face of Tension Arm Tube with gate UP

DESCRIPTION	DIMENSIONS	PART #
Secure Latch	4" x 2"	P55202

### Location "C", on the UP/DOWN switch box

DESCRIPTION	DIMENSIONS	PART #
UP – DOWN POWER DOWN	3 1/8" X 1-3/8"	P55330

If any decals are missing or become damaged, free replacements are always available from LEYMAN.

# ADD GREASE TO PIVOT JOINTS

---

This gate has greased bearings in some of the main pivot joints. Figure below shows the location of the grease fittings where grease should be applied. Use a grease gun that fits the grease fittings mounted in the positions shown. Push the grease gently into the pins until you see some grease coming out from the bearing edges. Please refer to Recommended Oils, Lubrication, Specifications Sheet for grease recommendations.

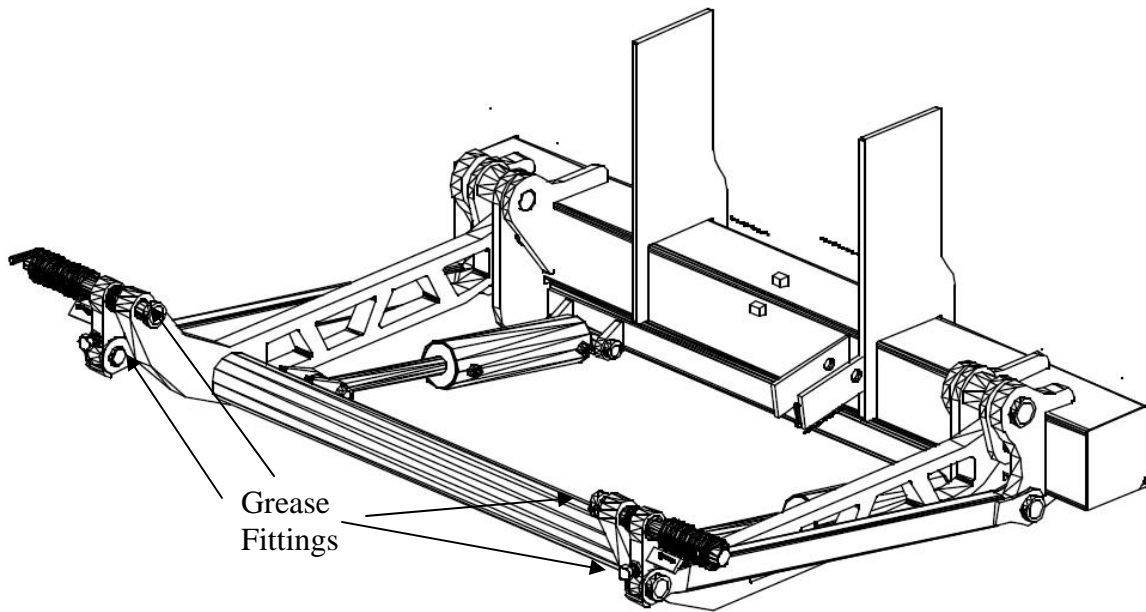

# ELECTRICAL & HYDRAULIC DIAGRAM

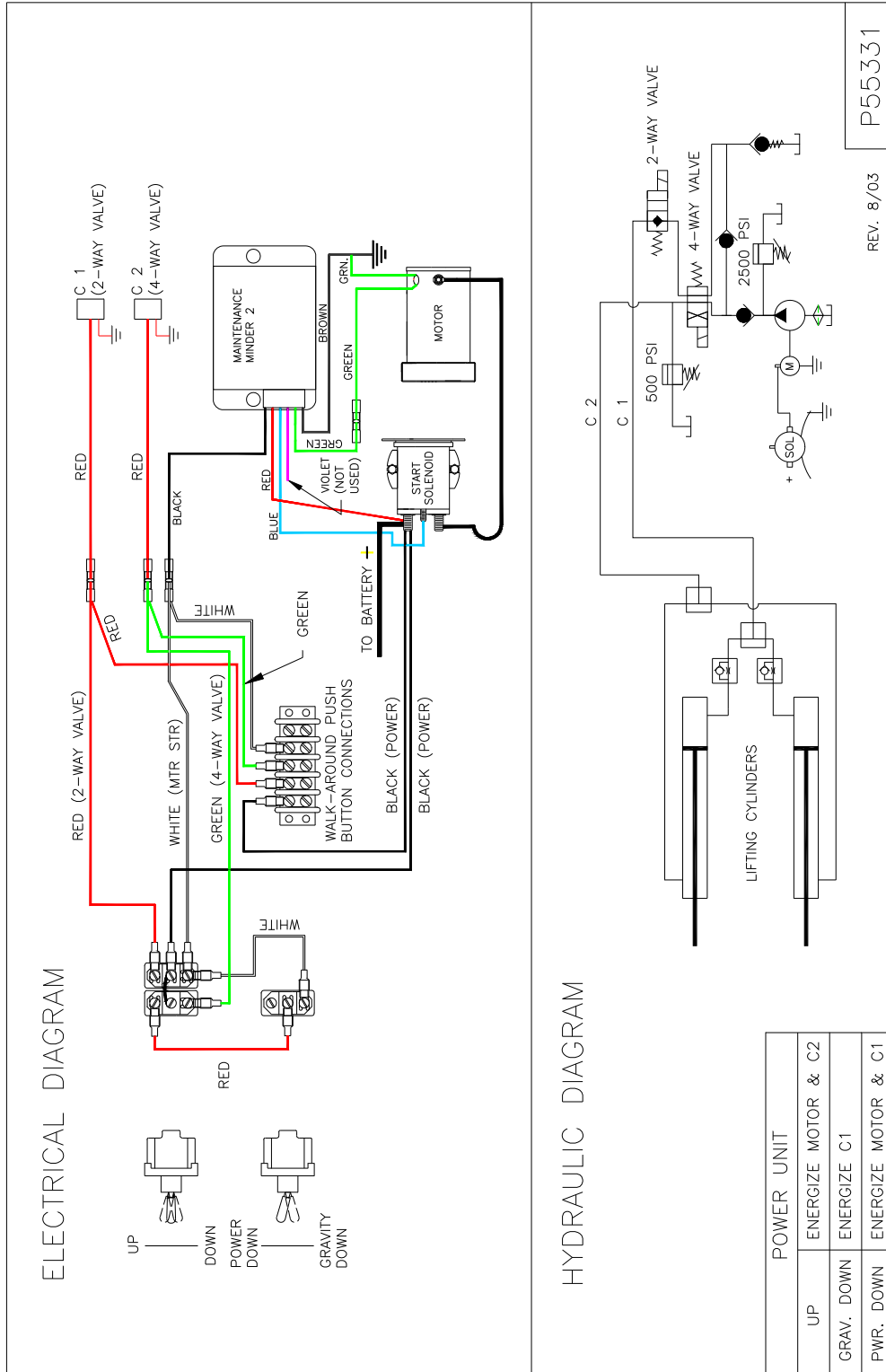

# MAINTENANCE MINDER 2<sup>®</sup> OVERVIEW

---

Power unit is equipped with the Maintenance Minder 2<sup>®</sup> Controller. It will:

- Automatically keep track of maintenance intervals and warn the user when maintenance is due, based on the number of lifts.
- Record low voltage occurrences.
- Record of high temperature faults.
- Record of maximum run time faults, when a single operation exceeded the maximum continuous run time limit.
- Give helpful trouble-shooting information on MENU 4, “Last Lift Info”.

## FAULTS CODES

A decal in the power unit enclosure lists the following signal codes for these faults:

1 BEEP	Service Fault (reached the number of lifts when maintenance is due)
2 BEEPS	Low Voltage Fault (check battery condition and power line connections)
3 BEEPS	Max. Time Fault (exceeded the maximum continuous run time allowed)
4 BEEPS	High Temperature Fault (unit will not run until motor cools)

All faults signals will be repeated FOUR times, except the Service Fault signal. Controller will prevent power unit from operating during the time period when a fault signal is sounding (about 5 to 10 sec.) except for the Service Fault signal. The controller is also equipped with an anti-doorbelling feature, which prevents rapid ON/OFF operation of the power unit.

## RESETTING after MAINTENANCE IS PERFORMED

To RESET the Maintenance Minder 2<sup>®</sup> after maintenance has been performed:

1. Go to MENU 2, hit “ENTER”, and toggle down to the “Reset All Info” screen.
2. Press and hold the hidden RESET button under Maintenance Minder 2<sup>®</sup> logo at top of faceplate.
3. Follow the instructions on the screen regarding a second button, which must be pressed to complete the reset operation.



# MAINTENANCE MINDER 2<sup>®</sup> CONTROLLER MENUS

---

**(Press MENU)**

**MENU 1 – LIFT GATE INFO**

**(Press ENTER, then ARROW DOWN for each item)**

Model Number, Serial Number, Manufacture Date, Vehicle ID, Hardware Version, Firmware Version, Software Version.



**(Press MENU and ARROW DOWN once)**

**MENU 2 – PERIOD INFO** (data for current maintenance period)

**(Press ENTER, then ARROW DOWN for each item)**

**Number of Lifts** (gives the number during this maintenance interval and the set number when maintenance is due)

**Motor ON** (total motor run time in minutes for this maintenance period)

**Service Fault** (number of times gate was operated PAST the maintenance limit)

**Max. Time Faults** (times motor exceeded its maximum allowable continuous run time)

**High Temperature Faults** (times thermal switch in motor tripped, if switch provided)

**Low Voltage Faults** (times low voltage occurred)

**Reset all Info** (Reset data after performing maintenance, once maintenance limit is reached – see reset instructions on previous page)



# MAINTENANCE MINDER 2<sup>®</sup> CONTROLLER MENUS

---

**(Press MENU and ARROW DOWN twice)**

MENU 3 – LIFE TIME INFO (data for the total life time of the gate)

**(Press ENTER, then ARROW DOWN for each item)**

Same items will appear as under PERIOD INFO, except this is LIFE TIME data.

**Reset History** (reviews history for each maintenance interval)

**Press ENTER, then ARROW DOWN to show history.** Most recent period is the highest #. Screen shows Period #, # of Lifts, and Total Run Time in minutes.



**(Press MENU and ARROW DOWN three times)**

MENU 4 – LAST LIFT INFO (Trouble Shooting Screen – it records data that occurred during the last lift made)

**(Press ENTER, then ARROW DOWN for each item)**

**Supply Voltage** (first voltage is the minimum voltage that occurred during the last lift – if below 6 volts gate will stop / second voltage is the supply voltage just before gate operation, must be at least 10 volts).

**Motor ON** (motor run time in seconds during last lift, gate will stop at 180 seconds).

**Window Time** (time in milliseconds during the last lift that the voltage dropped in between 6 and 8 volts – must not be any longer than 3 seconds or gate will stop).



## NOTE:

Controller has an anti-doorbelling feature. Motor will not operate if UP switch is toggled rapidly. This prevents welding of the start solenoid contacts.

# WALK AROUND PUSH BUTTON OPTION

**CHANGES**

A	ADDED RJM 5/1/06
B	ADDED RJM 4/13/07
C	CREATED SUBASSY RJM 10/07

**INSTALLATION INSTRUCTIONS:**

- 1) SELECT A LOCATION FOR MOUNTING THE 4-WAY SOCKET ASSEMBLY AND WELD THE MOUNTING PLATE IN PLACE.
- 2) MOUNT SOCKET AND RUN CABLE TO POWER UNIT. SUPPORT CABLE USING LOOM CLAMPS AND SCREWS.
- 3) ASSEMBLE CORD GRIP IN POWER UNIT BOX HOLE. INSERT CABLE THRU CORD GRIP AND CUT TO REQUIRED LENGTH. INSTALL FORK TERMINALS WITH HEAT SHRINK SEALS. CONNECT TO TERMINAL STRIP BY MATCHING WIRE COLORS.
- 4) SELECT A LOCATION FOR PUSH BUTTON HOOK ASSEMBLY AND MOUNT.

14	1	AA-999-180	P. B. HOOK ASSY.		NOT SHOWN
13					
12					
11	5	P17518	SELF TAPPING SCREW		NOT SHOWN
10	5	P46250	LOOM CLAMP		NOT SHOWN
9	1	P46139	CORD GRIP		NOT SHOWN
8	4	P46476	LOCKING FORK TERMINAL		NOT SHOWN
7	1	BA-551-352	WAPB ASSEMBLY		
6					
5	2	P23502	LOCK NUT	1/4	
4	2	P26007	FLAT WASHER	1/4	
3	2	P10517	BOLT	1/4-20 X 5/8	
2	1	BA-551-480	4-WAY SOCKET ASSY.		
1	1	AP-551-236	MTG PLATE		

TOLERANCE		LEYMAN MANUFACTURING CORPORATION	
FRACTIONS ± 1/64	RJM	PART NAME	MODEL LHLP4500/5500
DECIMAL ± .005	1/2/03	WAPB KIT	ASSY. WAPB OPTION
DR. HOLE ± .002-.000	CHECK	OPT. 103LHLP	BA-551-353
ANGLE ± 1/2°	APPR.	TOTAL WEIGHT	SCALE 1/4
UNLESS OTHERWISE NOTED			SH. DF



# EMERGENCY HAND PUMP OPTION

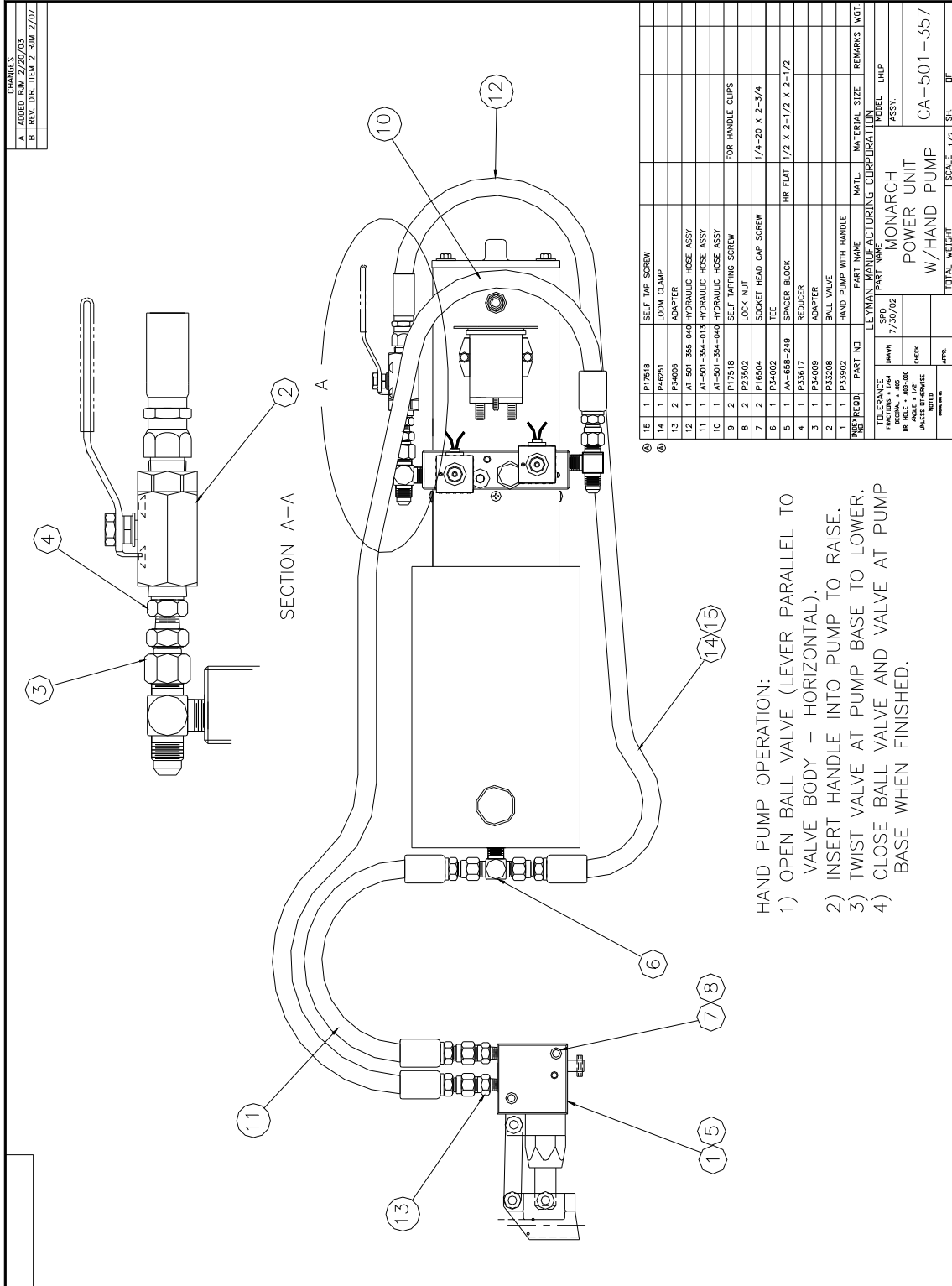

**HAND PUMP OPERATION:**  
 1) OPEN BALL VALVE (LEVER PARALLEL TO VALVE BODY - HORIZONTAL).  
 2) INSERT HANDLE INTO PUMP TO RAISE.  
 3) TWIST VALVE AT PUMP BASE TO LOWER.  
 4) CLOSE BALL VALVE AND VALVE AT PUMP BASE WHEN FINISHED.

CHANGES	
A	ADDED RJM 2/20/03
B	REV. DIR. ITEM 2 RJM 2/07

QTY	PART NO.	DESCRIPTION	UNIT
15	P17518	SELF TAP SCREW	
14	P46261	LOOM CLAMP	
2	P34006	ADAPTER	
12	AT-501-505-040	HYDRAULIC HOSE ASSY	
11	AT-501-504-013	HYDRAULIC HOSE ASSY	
10	AT-501-504-040	HYDRAULIC HOSE ASSY	
9	P17518	SELF TAPPING SCREW	
8	P23502	LOCK NUT	
7	P16504	SOCKET HEAD CAP SCREW	
6	P34002	TEE	
5	AA-658-249	SPACER BLOCK	
4	P33617	REDUCER	
3	P34009	ADAPTER	
2	P33208	BALL VALVE	
1	P33902	HAND PUMP WITH HANDLE	

INSTRUC	RECORD	PART NO.	PART NAME	MATL	MATERIAL SIZE	REMARKS	WGT
			LEYMAN MANUFACTURING CORPORATION				
			MONARCH				
			POWER UNIT				
			W/HAND PUMP				
			CA-501-357				

# RECOMMENDED OILS, LUBRICATION, SPECIFICATIONS

HIDE-A-WAY® TUCKUNDER STYLE GATE MODEL LHLP5500G

HYDRAULIC OILS	MANUFACTURER	TYPE	TEMP. RANGE
Level 1 Normal Conditions	Mobile	DTE 11	-15° F to + 150° F
	Shell	TELLUS-T15	-15° F to + 150° F
	Chevron	RYKON ISO-15	-15° F to + 150° F
Level 2 Cold Conditions	Mobile	AERO-HFA	-50° F to + 80° F
	Shell	AERO FLUID#4	-50° F to + 80° F
	Chevron	AVIATION-A	-50° F to + 80° F
	Mil	H-5606	-50° F to + 80° F

HYDRAULIC TANK CAPACITY
3.80 quarts

LUBRICATION	
Grease	Multi-purpose lithium based grease with 3% molybdenum disulfide, high drop point. Multi-purpose calcium based grease for general automotive and industrial use, water stabilized, high drop point. Anti-friction bearing grease, calcium or lithium based, with EP (extreme pressure) additives. Extreme Pressure grease, calcium or lithium based, with EP additives.

BATTERIES
Two (2) 12 V D.C. Group 31 Heavy-Duty lead acid DUAL PURPOSE, or AGM

ELECTRICAL COMPONENT CONNECTIONS
Protect using FLUID FILM by EUREKA Chemical

AMPERAGE DRAW OF MOTOR
When raising platform (empty) approximately 120 AMP @ 12 volts. At bypass approximately 235 AMP @ 12 volts

LIFTING PRESURE SETTING
With platform at floor level and pump in bypass 2500 psi

MINIMUM VEHICLE FLOOR HEIGHT LADEN
48" vehicle floor height

MAXIMUM VEHICLE FLOOR HEIGHT UNLADEN
60" vehicle floor height

APPROXIMATE TIME EMPTY AT 80° F WITH 2 BATTERIES SPECIFIED
Time up: 17 – 19 seconds Time down: 17-19 seconds (power down)

# FINAL INSTALLATION INSPECTION

<b>CUSTOMER:</b>		
<b>LOCATION:</b>		
<b>VEHICLE:</b>	<b>LIFT GATE MODEL#:</b>	<b>LIFT GATE SERIAL#:</b>

<b>✓ = OK</b>	<b>N = NOT APPLICABLE</b>
---------------	---------------------------

	WELDING/BOLTING
	Gate is welded secure to the vehicle (mounting plates are welded to chassis frame)
	Mounting plates are welded to Trunion Tube
	Bed Extension is weld to the vehicle
	Optional Steps welded to Bed Extension
	Reinforcement brace for dock bumper welded to cross members. Brace comes with steps.
	All bolts are tighten and secure
	Optional ICC Bumper installed.
	Safety latch and chain for over road position welded securely.
	ELECTRIC'S
	Check that the battery holds downs are anchored securely
	Check battery(ies) for proper charge level. <b>PROPER CHARGE LEVEL:</b>
	Check all wiring connections for tightness (batteries, switches, etc.). Connections sprayed with sealer.
	Inspect and check all circuit breakers/fuses
	Charge line/power line (through cross members with rubber grommets if you prefer)
	Charge line/power line (clamped to bottom of cross members with loom clamps)
	Electric line from switch to power pack (through cross members with rubber grommets if you prefer )
	Electric line from switch to power pack (clamped to bottom of cross member with loom clamps)
	Check operation of switch and walk around, if applicable
	HYDRAULIC AND LUBRICATION
	Check reservoir for correct amount of fluid (platform should be open & down position when checking)
	Check hydraulic hoses and fittings for leaks
	Check lifting cylinders for leaks
	Check greased bearings for proper application of grease.
	OPERATION OF GATE
	Open and closed lift gate. Observe for correct operation, platform folds and unfolds properly with clearance.
	Raise lift gate. Platform is even with Bed Extension and floor. Empty platform adjusted to proper slope.
	Lower lift gate (platform brackets hit the ground, then platform tilts and platform tip hits the ground).
	ICC bumper does not hit the ground when gate is all the way down with platform on the ground.
	PAINTING AND SAFETY STICKERS
	Repaint where needed
	Check hydraulic cylinder rod for over spray
	Install all safety and operation decals.

