

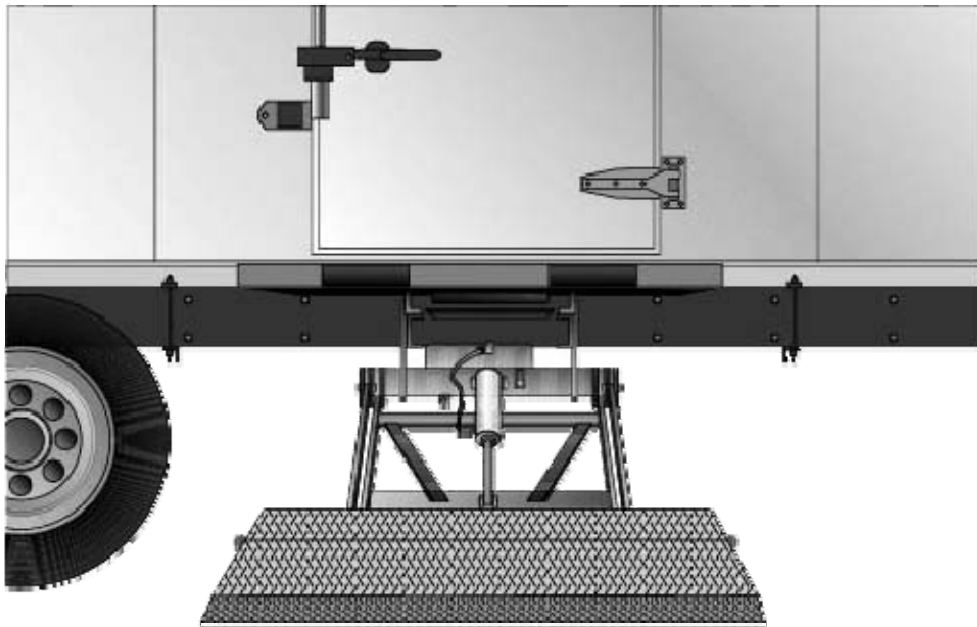

Installation Manual

TSG Hide-A-Way[®]

Truck Side Gate



10900 Kenwood Road • Cincinnati, OH 45242
Ph: 513-891-6210 • Toll-Free: 866-539-6261
Fax: 513-891-4901
www.leymanlift.com • sales@leymanlift.com

TABLE OF CONTENTS

Words of Caution	3
Operating of the Lift gate	4
General View – Truck Mounting	5
Truck Prep before Mounting Gate	6
Mounting Gate to Truck (side door)	6 - 12
Mounting Plate Assembly - Reference	9
Recommended Oils	13
TSG Wiring	14
Decal placement	15
Final Inspection	16
Troubleshooting Chart	17
Installer Notes	18

WORDS OF CAUTION

1. Before any maintenance is performed on this unit, read and understand this manual completely.
2. Do not stand on or behind the platform when operating gate in the folded position.
3. Make sure the ground is clear under the platform when lowering.
4. Do not stand in front of platform when lowering from vertical position or operating in any manner.
5. Never exceed the rated load capacity of this gate.
6. Do not allow persons to operate the unit unless they have been properly trained to do so.
7. Use only factory authorized parts for replacement.
8. Check the area around the unit for persons before operating the lift gate.
9. This lift gate should operate smoothly and the only noise that should be heard is the power unit. Any audible sounds other than the normal power unit operation sound should be thoroughly inspected and the cause of the noise should be pinpointed and corrected.
10. Do not over load – the maximum rated capacity is based on an evenly distributed load all over the platforms flat surface.
11. Always load as close to the center of the platform and as close to the center of the truck sill as possible.
12. 150 Amp circuit breaker (not supplied) must be installed between the starter solenoid and the battery source.
Order from factory as option #111-Circuit Breaker.

We urge the installation of a safety cut-off switch for all truck mounted lift gates. These are installed in the cab of the vehicle, so the power to the lift gate can be turned on/off.

WARNING: Pressure relief valve in power unit must NEVER be set above 2500 psi. Pressures above 2500 psi can damage lifting arms. Failure to follow this warning could result in accident or injury.

WARNING: Since this gate has greaseless bearings in the main pivot points, (tension and compression arms and platform parts) any welding on these parts must be grounded or you will damage the cylinder.

OPERATING OF THE LIFT GATE

- Before operating the lift, read and understand this decal, urgent warning decal, and the Owner's Manual.
- Do not stand behind the lift gate while unfolding or using the platform.

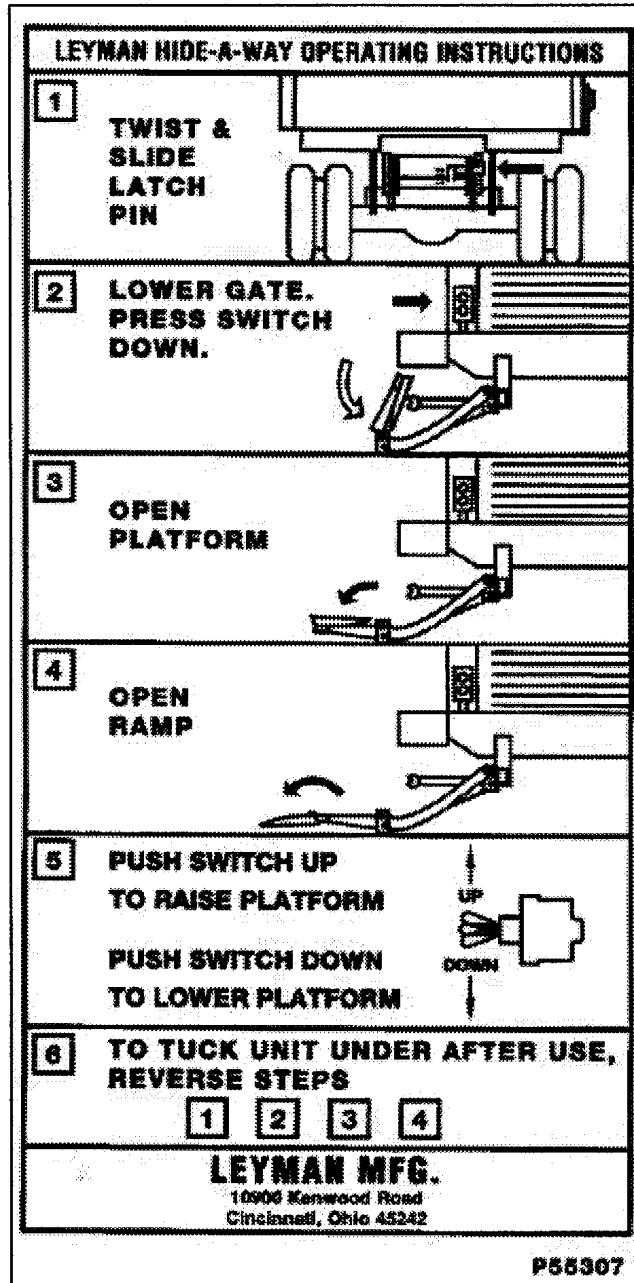

GENERAL VIEW, TRUCK MOUNTING TSG GATE

IMPORTANT: SUPPORT TRUCK CHASSIS BEHIND TSG MOUNTING PLATES BY RUNNING TWO RECTANGULAR PLATES BETWEEN CHASSIS CHANNELS

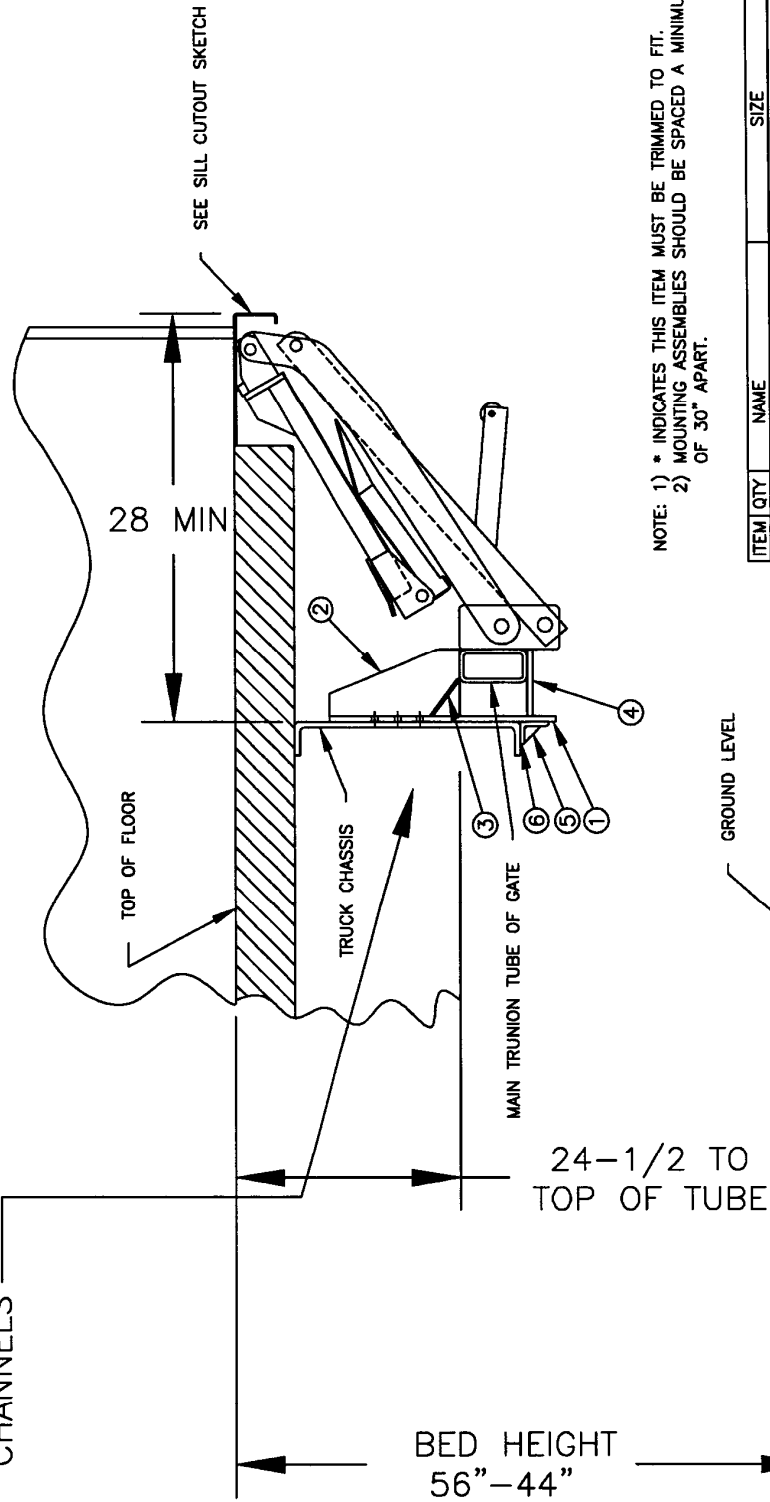

NOTE: 1) * INDICATES THIS ITEM MUST BE TRIMMED TO FIT.
2) MOUNTING ASSEMBLIES SHOULD BE SPACED A MINIMUM OF 30" APART.

ITEM	QTY	NAME	SIZE
1	2	MOUNTING PLATE	1/2 X 10 X 20
2*	2	GUSSET	1/2 X 6 X 11-1/2
3*	4	BRACE	1/4 X 4 X 4
4*	2	SUPPORT	1/2 X 4 X 6
5	4	SMALL GUSSET	1/4 X 1-1/2 X 1-1/2
6	2	ANGLE	2-1/2 X 2 X 3/8 X 8

Step 1: TRUCK-PREP BEFORE MOUNTING GATE

1. Carefully check dimensions given on page 5. Verify you have the proper space available to mount the gate. 24-1/2" represents the standard mounting height. For a bed height of 44", this mounting height will yield 10" ground clearance (unladen).
2. If more ground clearance is required, or the bed height is less than 44", the 24-1/2" mounting dimension can be reduced. For every 1" reduction in the 24-1/2" dimension, you will need approximately one additional inch in clearance between the door sill and truck chassis (beyond the 28" minimum dimension). Example: if the mounting dimension is reduced to 22-1/2", you will need approximately 30" between the door sill and the truck chassis.
3. Once it is clear, the proper space is available for gate installation, the door sill must be notched per dimensions on page 7. It is important the sill be reinforced after notching using gussets as described on page 7. The sill must be strong since it serves as the "up" stop for the gate.

Step 2: MOUNTING GATE TO TRUCK (SIDE DOOR)

1. Unfold the secondary platform.
2. Clamp the secondary platform to the lift truck approximately centered (see illustration on page 8).
3. There are two angles in the shipping kit (5 x 3 x 1/4 x 3 lg.). Lay these two angles on top of the door sill to space the platform out 1/4" (see sketch on page 8).
4. Pick up the gate assembly. Position it at the door opening as required and push it against the sill and the 1/4" spacers. With two pieces of scrap channels or angles, clamp platform flush with floor. Use four clamps. Clamp channels to sill and platform. Flat area of platform farthest away from truck should be 1" higher than door sill to allow for platform deflection under load. Step 16 on page 11, explains how to use the shims provided to adjust platform slope.
5. With a floor jack and piece of 4 x 4 wood, swing and raise the main tube until it is at the 24-1/2" standard dimension – or a reduced dimension if needed. With a pipe wrench rotate the main 4 x 6 trunion tube, so it is vertical. You should see approximately 3/8" of exposed rod on the cylinder if you used the standard 24-1/2" mounting height.

TSG SILL CUTOUT

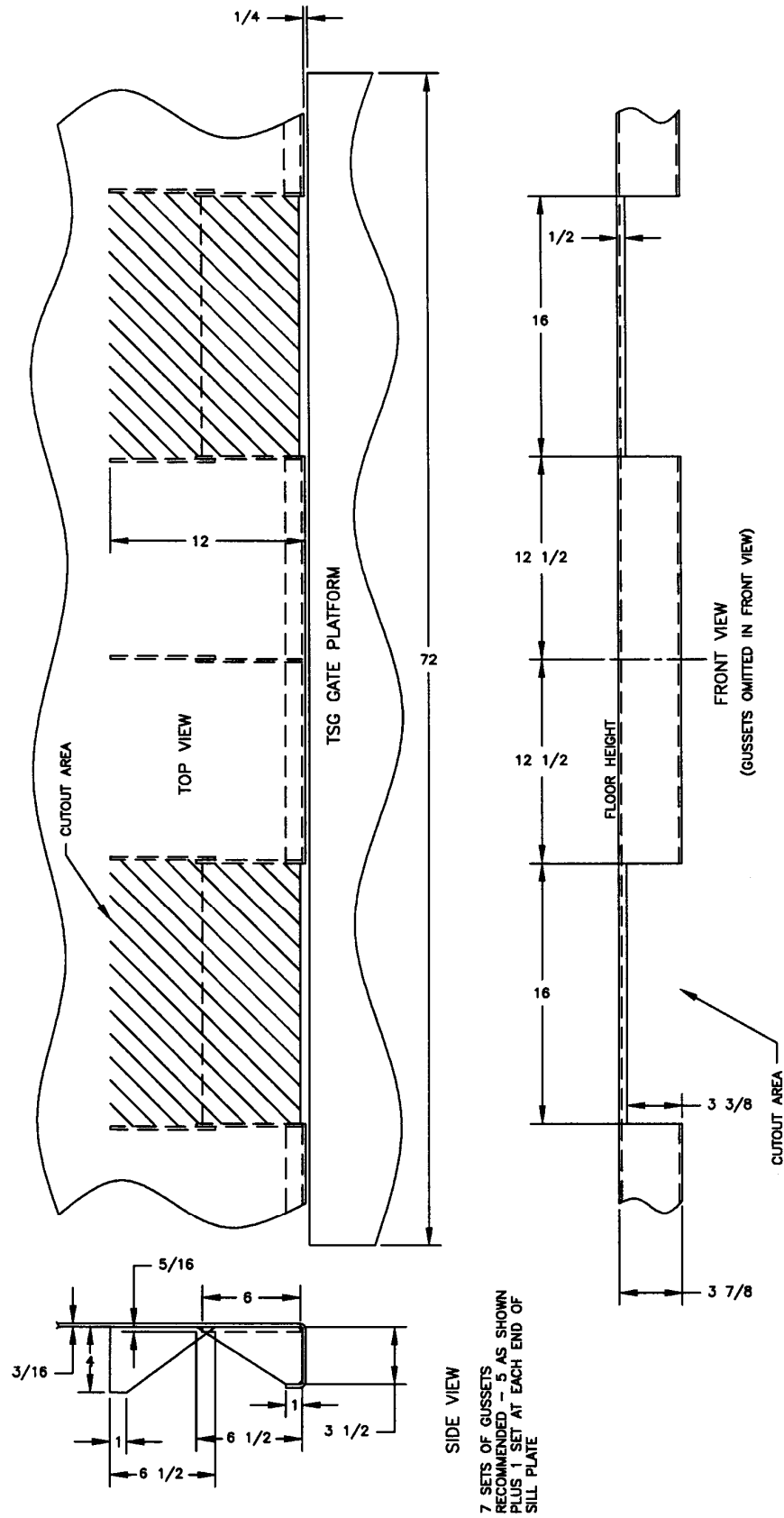

7 SETS OF GUSSETS
RECOMMENDED - 5 AS SHOWN
PLUS 1 SET AT EACH END OF
SILL PLATE

REF. DWG. BP-800-281

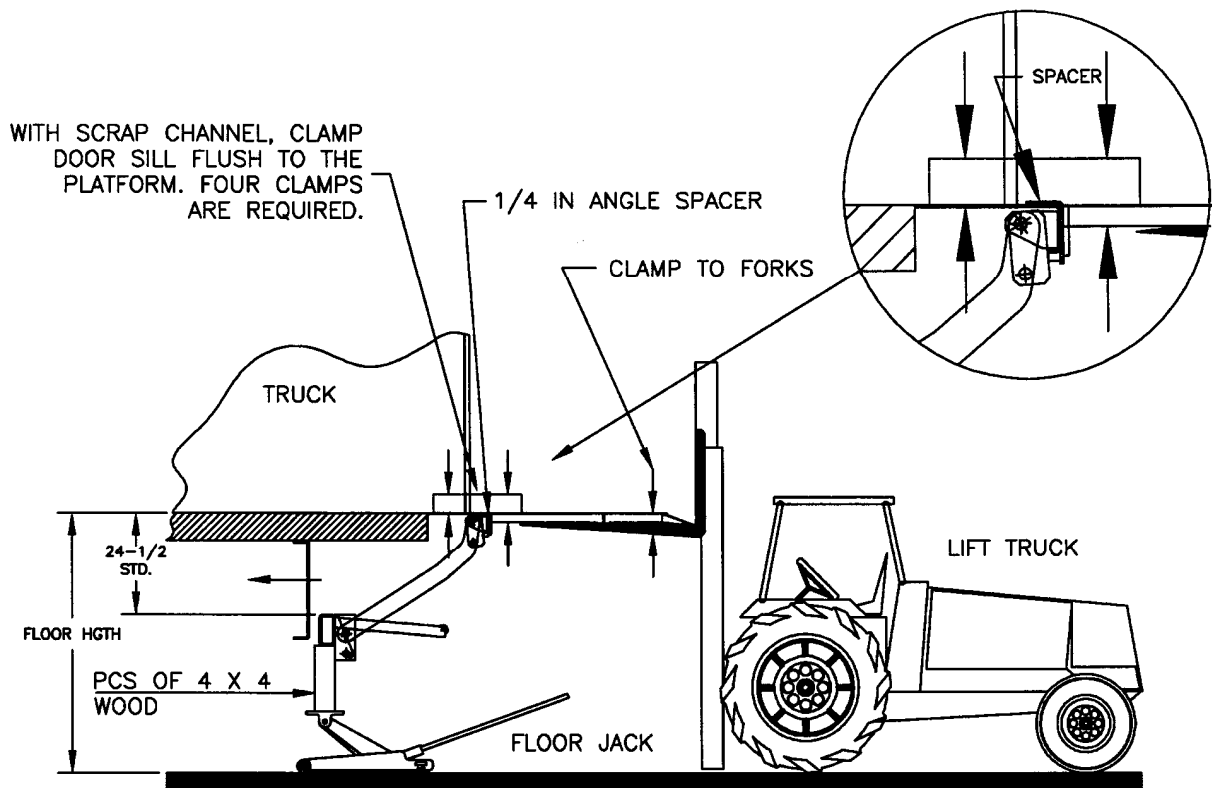

6. Now locate all the component parts, which make up the TSG mounting plate assembly, reference page 9 to identify them. The centerline of the two mounting plates should be spaced at least 30" apart. Hold parts up to locate holes required in truck chassis and mark gussets and plates for trimming.
7. Lower floor jack and let gate swing out of the way. Drill 9/16" holes through chassis to attach both mounting plates. Bolt plates in place using hardware supplied. Lift trunion tube of gate back in position.
8. Now tack weld the gussets and support plate to the mounting plate and trunion tube. Welds must be strong enough to support the gate without a load on the platform.
9. Locate a suitable spot to mount the power unit enclosure. Use the two brackets and shims supplied. Refer to the sketch on page 10. Connect the hydraulic hose and plastic tubing from the lift cylinder to the power unit.
10. Unclamp the four clamps holding the back of the platform next to the door sill.
Caution: Do not unclamp the tip of the platform.
11. Let the lift truck forks down slowly until they will not go any further. They will stop about half way down when they meet resistance from the oil in the lift cylinder.

MOUNTING PLATE ASSEMBLY

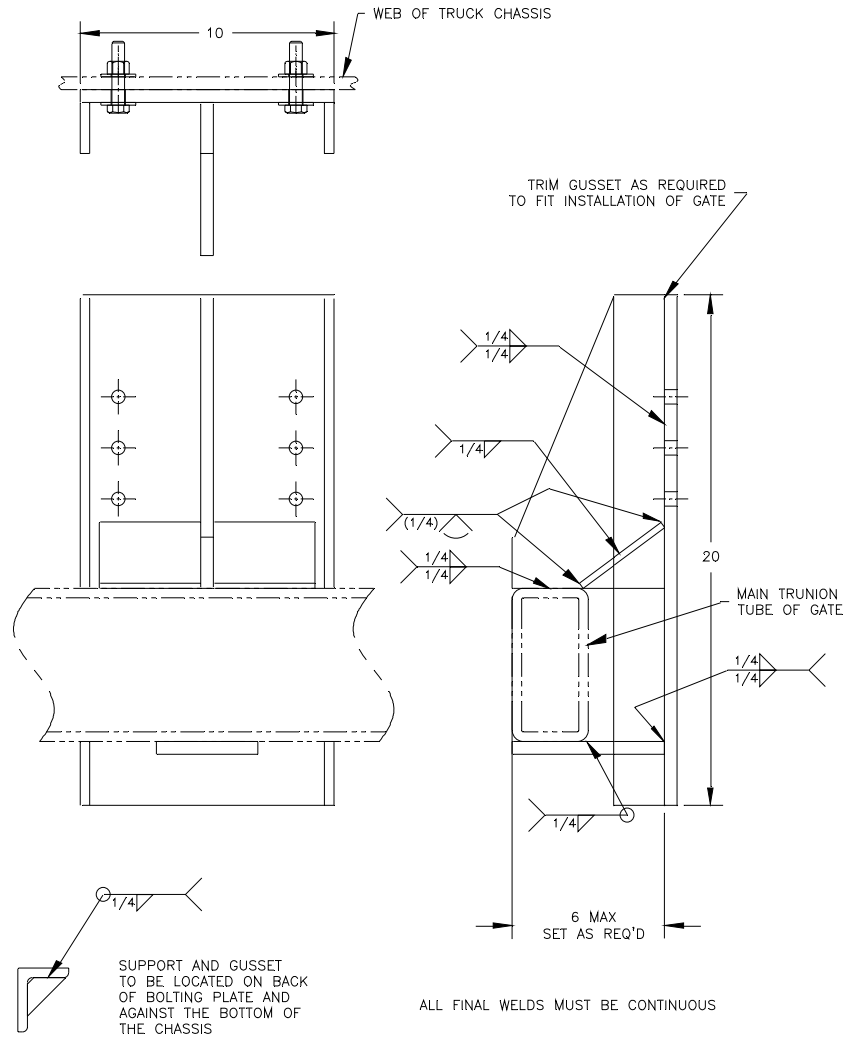

ALL FINAL WELDS MUST BE CONTINUOUS

REF. DWG. BA-800-285

Index#	Req'd.	Part #	Part Name	Material	Material Size	Remarks
1	2	BA-800-613	Mounting plate			
2	2	BP-800-284	Gusset			
3	12	P11029	Bolt	GR 8	1/2 -13 x 2-1/2	
4	12	P23511	Lock nut		1/2	
5	24	P26004	Flat washer		1/2	
6	2	S577-008.000	Support	St Angle	2-1/2x2x3/8x8	
7	4	AP-999-023	Gusset			
8	2	S154-006.000	Support	HR Flat	1/2 x 4 x 6	
9	4	S064-004.000	Brace	HR Flat	1/4x4x4	

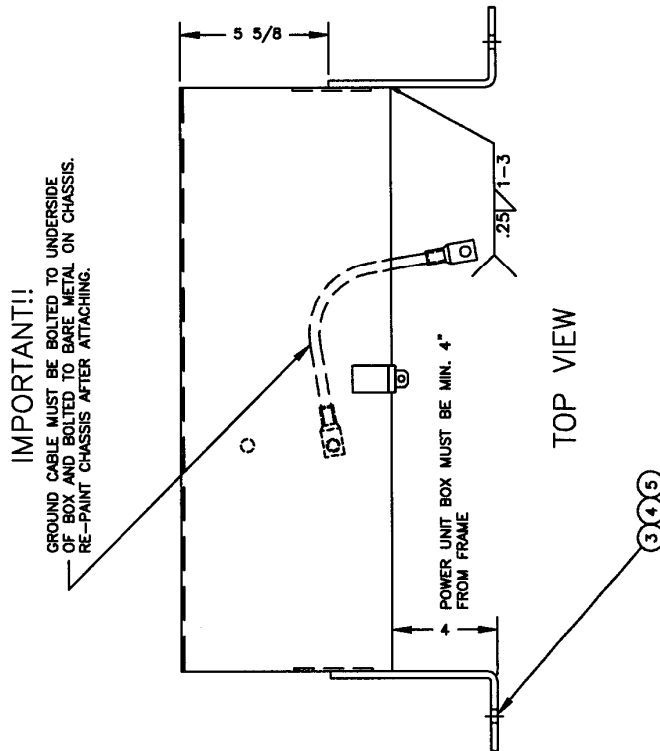
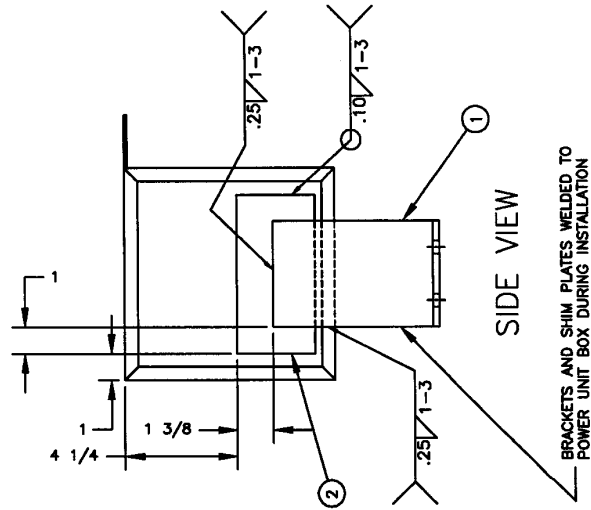

Index #	Req'd.	Part #	Part Name	Material Size
1	2	BP-800-288	Power unit bracket	
2	2	AT-998-007-112	Shim plate	1/8 x 3 x 6
3	4	P11029	Bolt	1/2-13x2-1/2
4	4	P23511	Lock nut	1/2
5	8	P26004	Flat washer	1/2

12. Install gate control switches in the desired location (refer to wiring on page 14) and route the wire to the power unit. Slide a piece of supplied shrink tube over the thermal switch wire and connect the black control wire to thermal switch wire using the butt connector pre-installed on the wire. Move the shrink tube to cover the connection and heat to shrink and seal the connection. Connect the white control wire to the lowering valve in the same manner. Attach the green control wire with ring terminal to the large open post of the starter solenoid.
13. Use a 12 volt battery for temporary power. Run a wire from the battery to the starter solenoid. Run a ground wire to the truck.
14. Run the gate up and down to check its operation. If the platform secondary has a fixed taper instead of a flip ramp, the fixed taper will be off the ground. It should come within 1" of the ground when the platform is loaded. TSG platforms are level ride.
15. If the gate operation is correct, finish weld the trunion tube to the mounting plates and gussets. Also, reinforce chassis channel behind TSG mounting plates by running two rectangular plates (not supplied) between the chassis channels.
16. Weld shims to stop blocks on platform for proper slope and preload (approximately 1" high at end of flat on secondary platform). 14 gauge shims provided in kit will give proper slope (see illustration below). and preload.

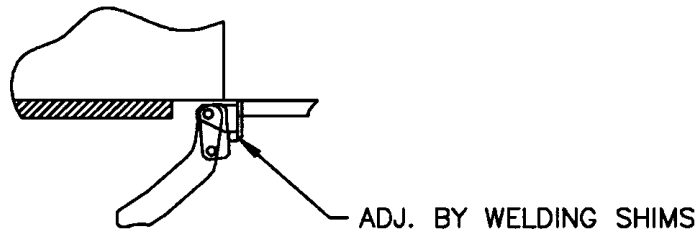

View with platform unfolded and in the full up position.

Caution: Attach ground to stop blocks before welding.

17. Weld on stop block for latch, which holds the gate up in the stored position. There should be a 1/16" gap between the block and the latch shaft (see illustration below). This block will hold the gate in the over-the-road position in the event of hydraulic failure.

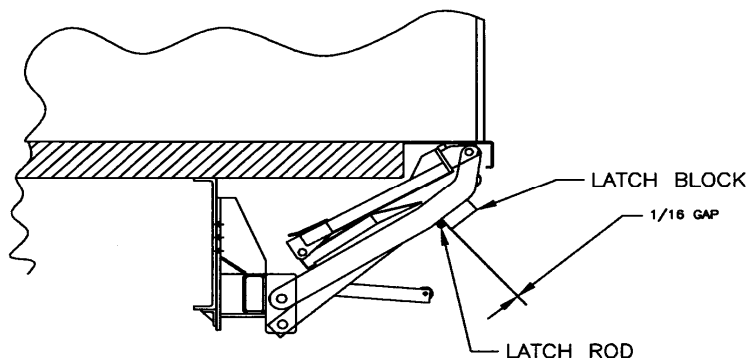

18. Adjust radius arm roller, if necessary (see illustration below).
Sometimes radius arm roller must be moved back to the next set of holes and tip cut off.

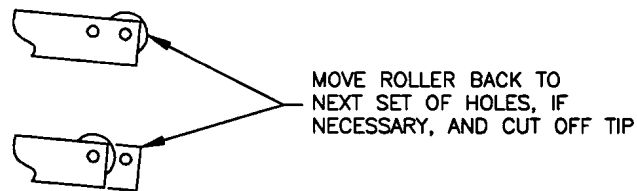

19. Weld on brackets to protect hydraulic cylinder (see illustration below). With platform in position shown (folded horizontal) weld platform brackets (angles-supplied) to tension arms, so the platform is resting on brackets approximately 1/2" above cylinder. Weld solid down both sides as shown (1/4 fillet weld).
Caution: Ground arms before welding brackets.

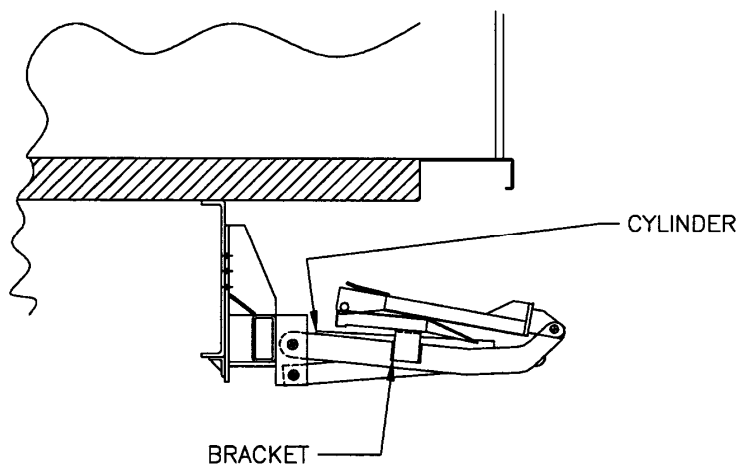

20. Trucks – Run 4 gauge power line from 150 amp circuit breaker (not supplied) or gate starter solenoid to the truck battery. **Caution:** Make sure there is a ground wire from battery to chassis.
21. Paint unit. Apply decals per diagram on page 15. Lubricate over-the-road latch barrel and pin. Check hydraulic oil level in power unit tank when platform is on the ground. Oil level should be about 1" from top of tank.

RECOMMENDED HYDRAULIC OILS

Level 1

Normal Conditions

<u>Manufacturer</u>	<u>Type</u>	<u>Temperature Range</u>
Chevron	RYKON ISO-15	-15°F to + 150°F
Mobil	DTE-11	-15°F to + 150°F
Shell	TELLUS-T15	-15°F to + 150°F

Level 2

Cold Conditions

<u>Manufacturer</u>	<u>Type</u>	<u>Temperature Range</u>
Chevron	AVIATION-A	-50°F to + 80°F
Mobil	AERO-HFA	-50°F to + 80°F
Shell	AERO FLUID #4	-50°F to + 80°F
Mil	H-5606	-50°F to + 80°F

TSG WIRING

POWER UNIT (Black Motor with Thermal Protection)

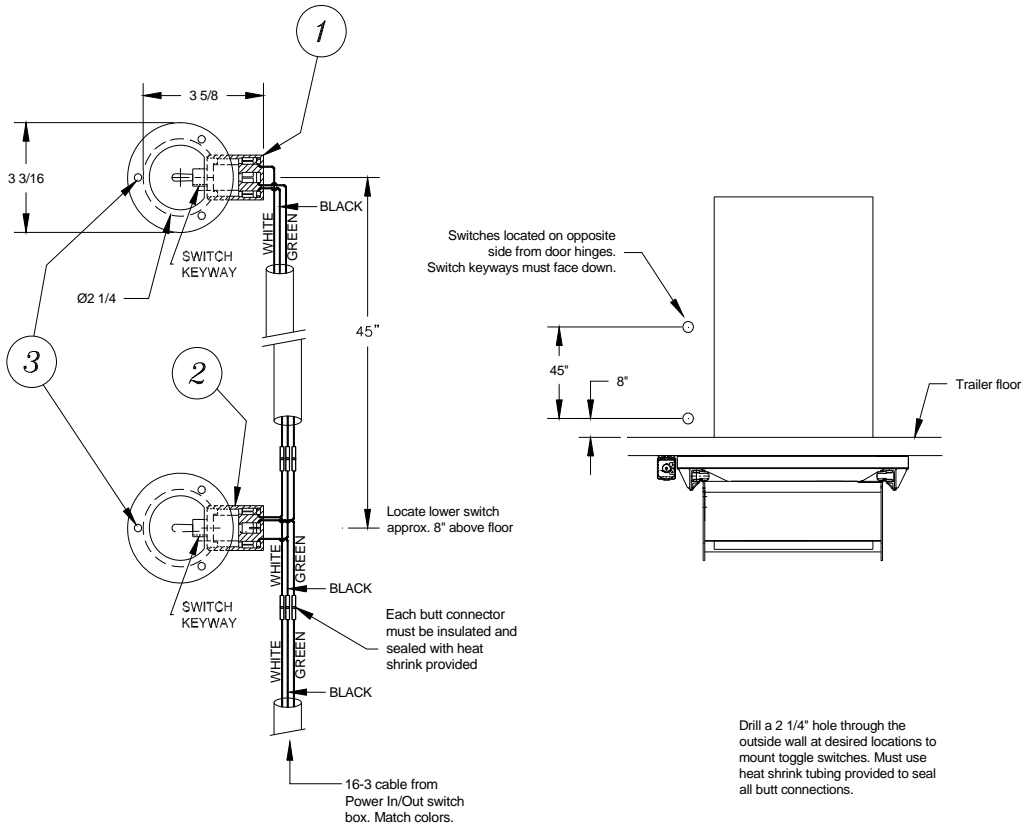
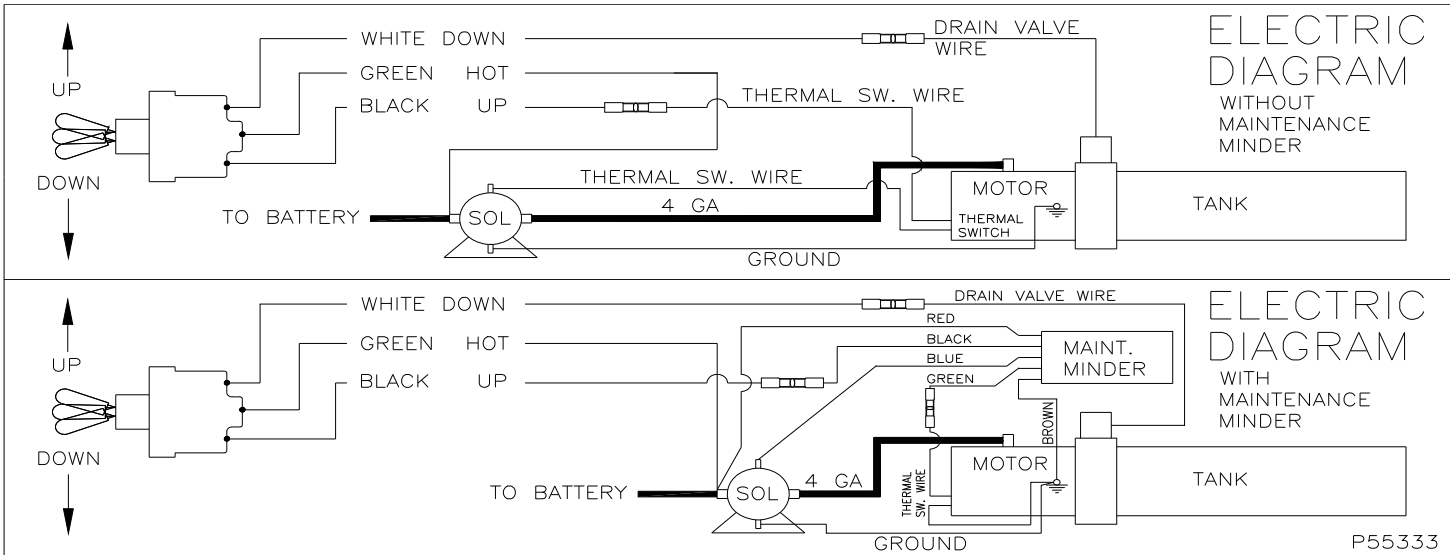

DECAL PLACEMENT

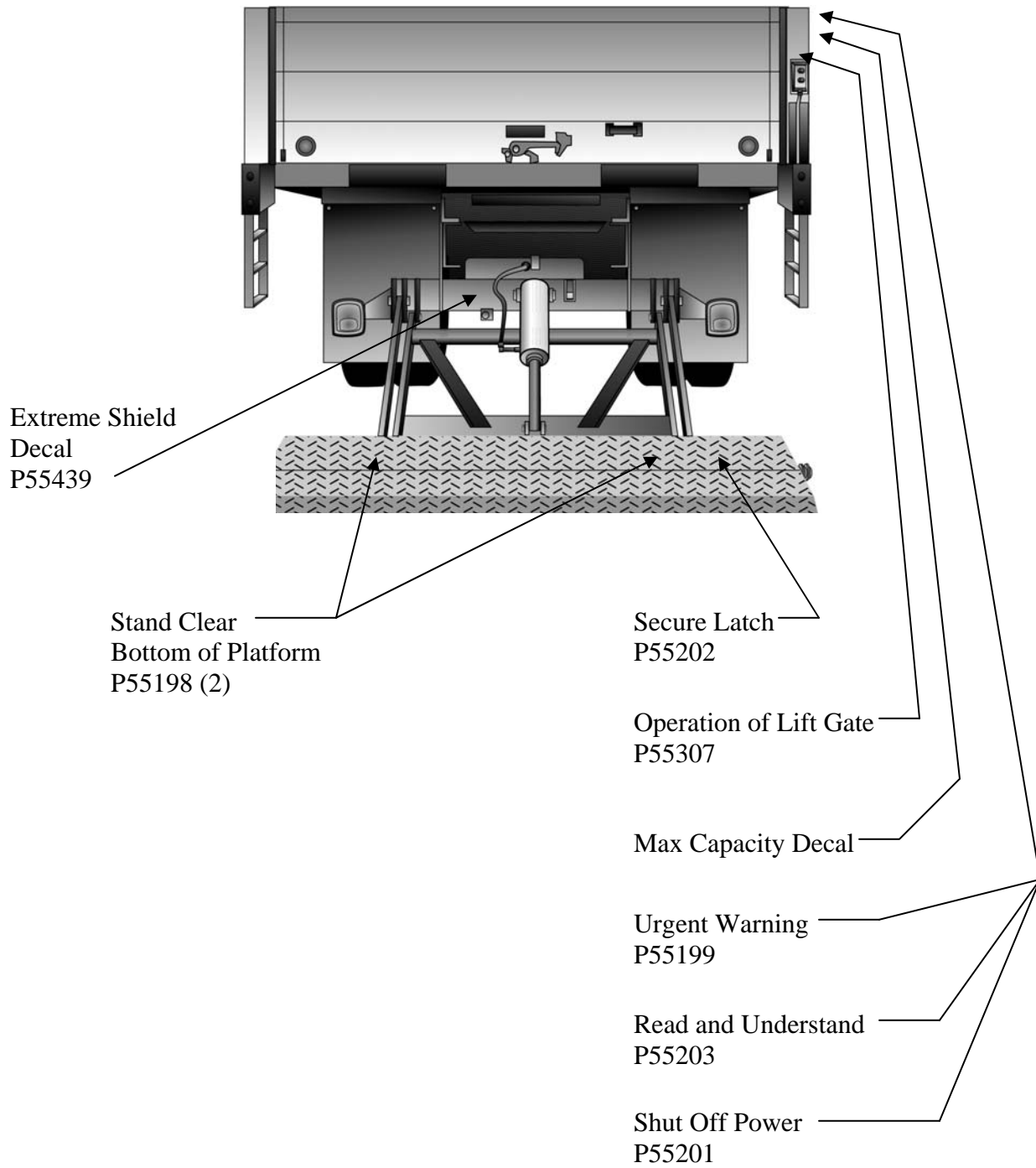

FINAL INSPECTION

CUSTOMER:		
LOCATION:		
VEHICLE#:	LIFT GATE MODEL#:	LIFT GATE SERIAL#:

√ = OK

N = NOT APPLICABLE

	WELDING/ADJUSTMENTS
	Gate is welded secure to vehicle (mounting plates are welded to chassis frame).
	Mounting plates are welded to cross bar tube.
	Extension is welded to vehicle (12-2" or 3" welds across floor and gussets welded inside and out).
	Corners and steps welded to vehicle. Steps are optional.
	Reinforcement braces for corners and steps welded to cross members.
	Battery box welded or bolted secure to cross members.
	All bolts are tightened and secure.
	ICC bumper bar tube installed (optional).
	Lock block welded on tension arm right side (for safety latch rod).
	ELECTRIC'S
	Check that battery holds downs are anchored securely
	Check battery(ies) for proper charge level. PROPER CHARGE LEVEL:
	Check all wiring connections for tightness (batteries, switches, etc.)
	Inspect and check all circuit breakers/fuses.
	Charge line/power line (through cross members with rubber grommets if you prefer)
	Charge line/power line (clamped to bottom of cross members with loom clamps)
	Electric line from gate to power pack (through cross members with rubber grommets if you prefer)
	Electric line from gate to power pack (clamped to bottom of cross members with loom clamps).
	Check operation of toggle switches
	HYDRAULIC/GREASE
	Check reservoir for correct amount of fluid (platform should be open and down when checking)
	Verify pressure relief valve set at 2500 psi.
	Check hydraulic hoses, fittings, and cylinder for leaks.
	Grease safety latch rod.
	OPERATION OF GATE
	Open and close lift gate. Observe for correct operation (platform folds and unfold properly)
	Raise lift gate. (platform is level with floor of vehicle).
	Lowering lift gate (platform brackets and tip of platform rest on the ground).
	ICC bumper does not hit the ground when gate is all the way down with platform on the ground.
	PAINTING AND SAFETY STICKERS
	Repaint where needed
	Check hydraulic cylinder rods for over spray
	Install all safety and operation stickers

TROUBLE SHOOTING CHART

ALL TSG MODELS

<i>PROBLEM</i>	<i>PROBABLE CAUSE</i>	<i>REMEDY</i>
The motor is running, but the platform will not go up, or reach floor of vehicle or gate will not lift rated load.	<ol style="list-style-type: none"> 1. Insufficient oil in power unit tank. 2. Lowering valve stuck partially or fully open. 3. Power unit relief valve is set too low. 	<ol style="list-style-type: none"> 1. Fill tank. 2. Clean or replace. 3. Turn screw in all the way, then back off one turn.
The platform will not go up or reach floor level and the motor does not run.	<ol style="list-style-type: none"> 1. Battery is low. 2. Power line is loose. 3. Poor switch connections. 4. Cab switch is turned off. 5. Defective starter solenoid. 6. Tripped circuit breaker. 	<ol style="list-style-type: none"> 1. Recharge the batteries. 2. Check the connection, if loose tighten. Also, check for corrosion and clean if necessary. 3. See #2. 4. Turn the switch on. 5. Replace part. 6. Reset the circuit breaker.
Platform will not lower.	<ol style="list-style-type: none"> 1. Battery is low. 2. Bad ground or electrical connection. 3. Lowering valve is bad. 	<ol style="list-style-type: none"> 1. Recharge the batteries. 2. Check for corrosion and tighten. 3. Check the coil.
Platform creeps downward.	<ol style="list-style-type: none"> 1. Defective cylinder or piston seal. 2. Lowering valve is not seating or is partially open. 	<ol style="list-style-type: none"> 1. Remove breather – activate to see if there is a continuous flow of oil. 2. Clean and inspect.
Platform goes down slowly.	<ol style="list-style-type: none"> 1. Lowering valve not fully open or is clogged. 2. Lines are restricted or flow control is clogged. 	<ol style="list-style-type: none"> 1. Clean and replace the lowering valve. 2. Check for bent or pinched lines. Clean or replace the flow control.
Bent latch pin.	<ol style="list-style-type: none"> 1. Latch block welded too far from the latch pin-allows mechanism to bounce. 2. Cylinder leaking. 	<ol style="list-style-type: none"> 1. Weld block 1/16 away from pin. 2. Remove breather – activate to see if there is a continuous flow of oil.
Hydraulic oil leak from cylinder rod end.	<ol style="list-style-type: none"> 1. Loosen gland out. 2. Cylinder rod pitted. 	<ol style="list-style-type: none"> 1. Turn gland nut 1/2 turn – do not over tighten. 2. Replace cylinder.

