

Installation & Operator's Manual

LS6 Liquid Spray System for SHPE1500, 2000 Style Spreaders

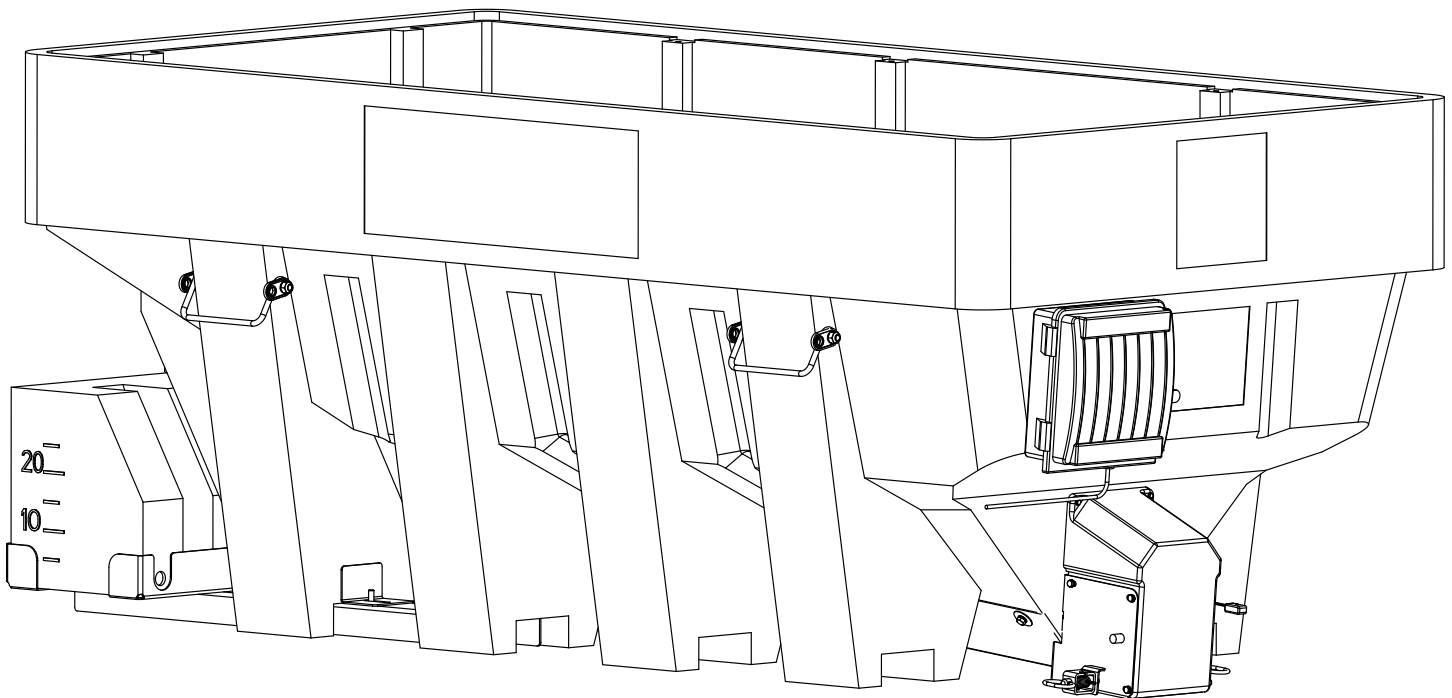

Installation Instructions

- 1.** Position Support (3013939) in truck's bed. Place 30 gal. Tank (#3014062) on support as shown in Fig.1. Strap tank to support using straps 149650501.
- 2.** Lower spreader onto support, Make sure support's long brackets are inside of spreader legs openings and screws are between two front legs as shown in Fig.2
- 3.** Secure spreader on support using stops (3014065) and provided hardware as shown in Fig.3.
- 4.** Position and attach enclosure LS102 as shown in Fig.4.
- 5.** Plumb: reservoir, ball valve, filter, pump enclosure and spray nozzle according to plumbing schematic using supplied fittings, hose and hose clamps. Do not use Teflon tape on threads. Use liquid thread sealant. (see fig.5, 6,7 &8).

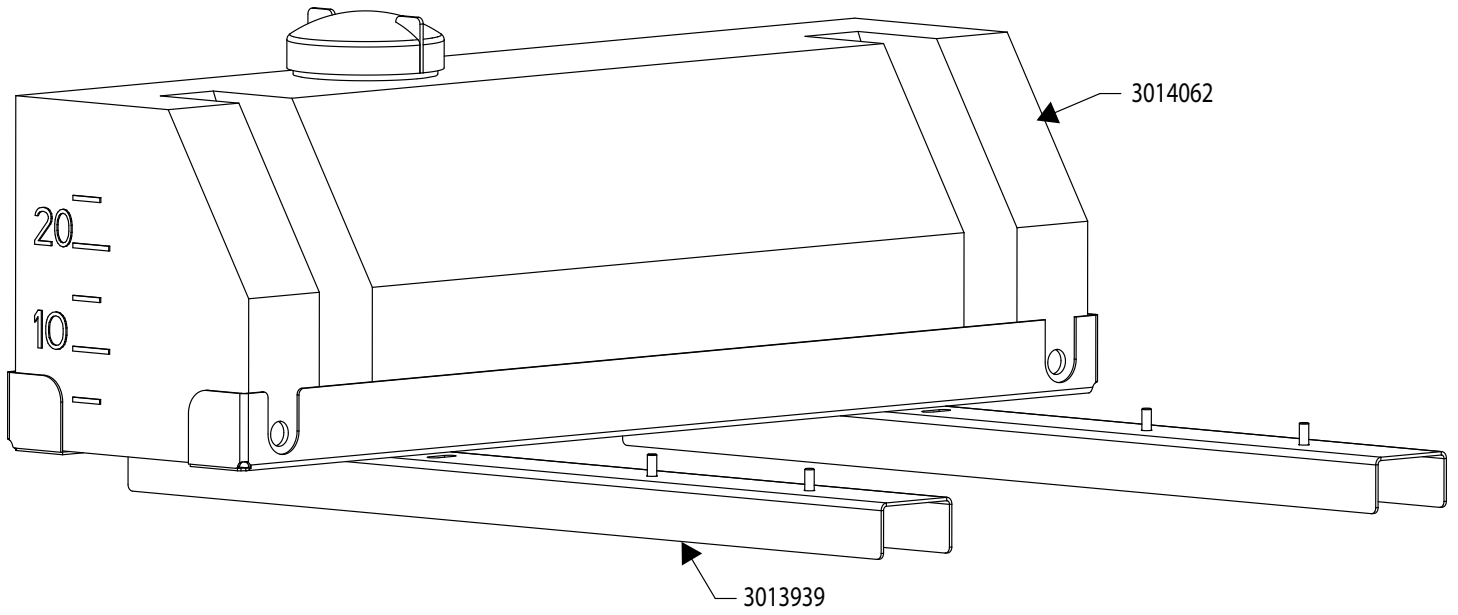

Fig. 1

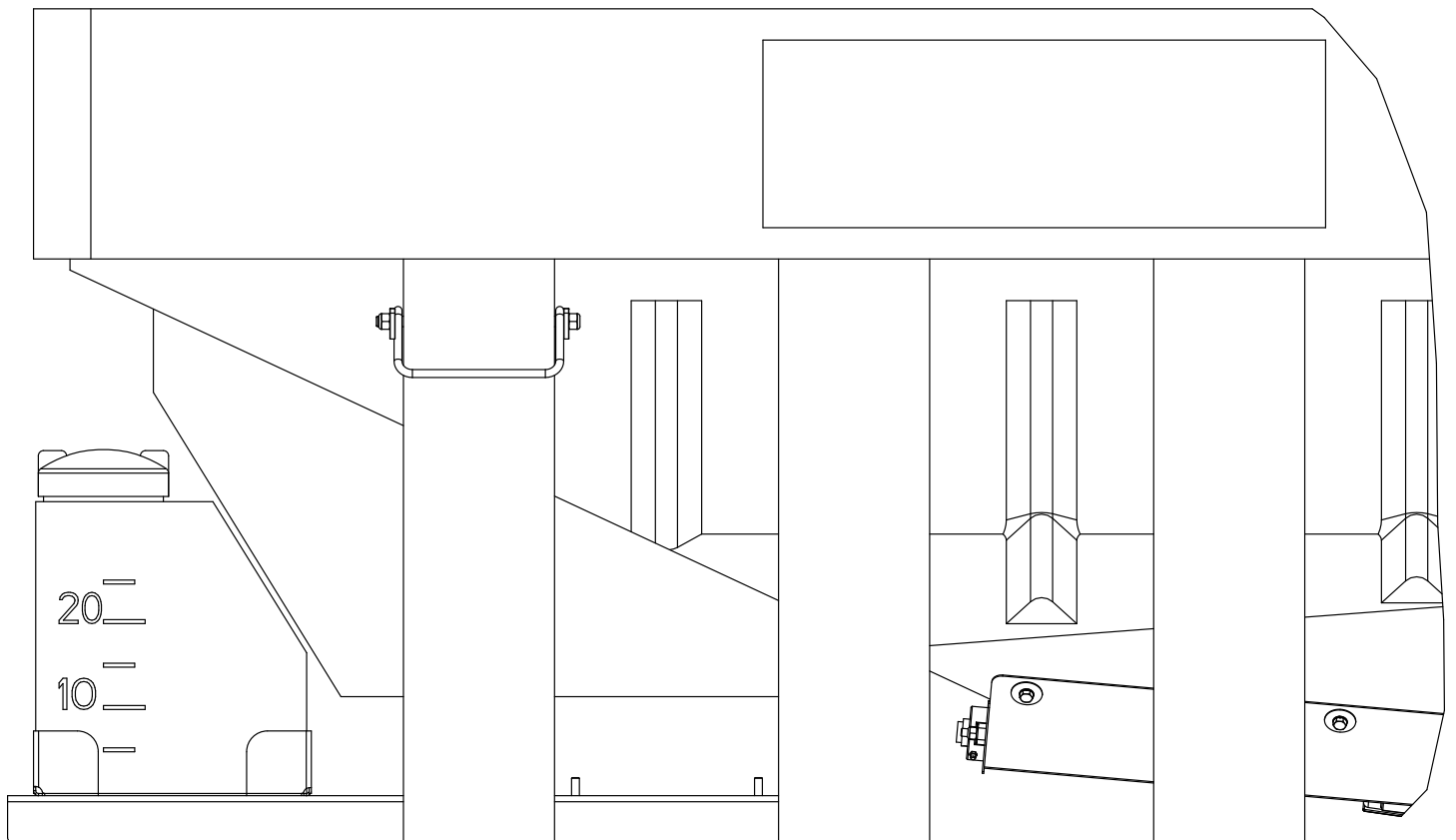

Fig. 2

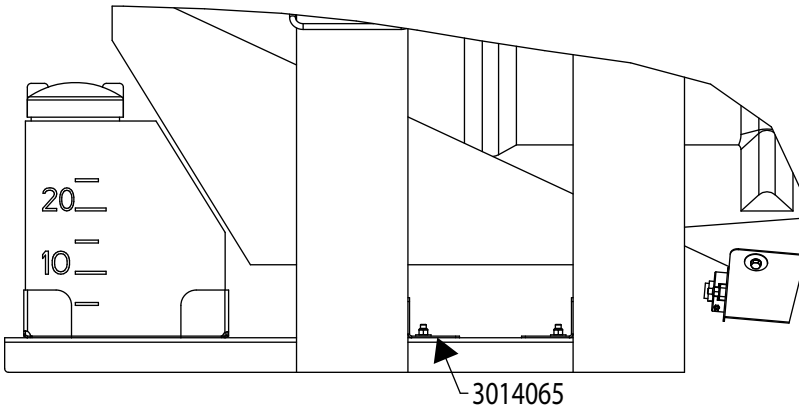

Fig. 3

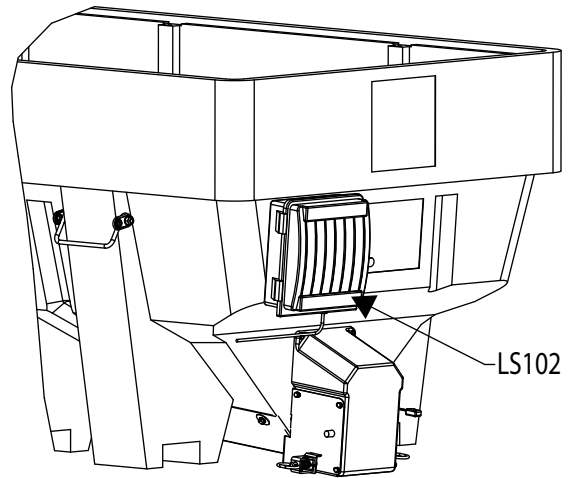

Fig. 4

Cab Controller Installation

Instructions (Fig. 5)

- 1.** Install cab controller (#WSE1) in cab for convenient driver operation. Mounting bracket and fasteners included.
- 2.** Route 8' wire harness (#WSE24) under dash from controller (#WSE1) to truck's fuse panel.
- 3.** Ground "black" wire from controller to truck frame or truck's battery (not dash).
- 4.** Attach "green" wire in 8' wire harness (#WSE24) to a fused and keyed 15 Amp hot wire circuit.
- 5.** Connect main power "white" wire in 8' wire harness (#WSE24) to fuse box that is "hot" full time or to battery "positive".
- 6.** Route the 25' wire harness (#WSE25) from the rear of the spreader to the cab. Plug connector on controller (#WSE1) to the connector on pump harness (#WSE25).



Fig. 5 WSE1 Cab Controller, front view

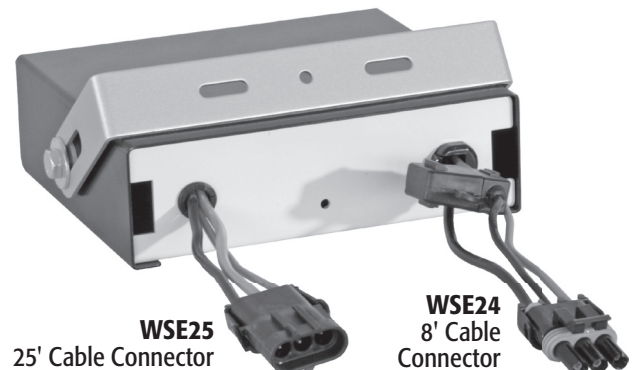

Fig. 5 WSE1 Cab Controller, back view

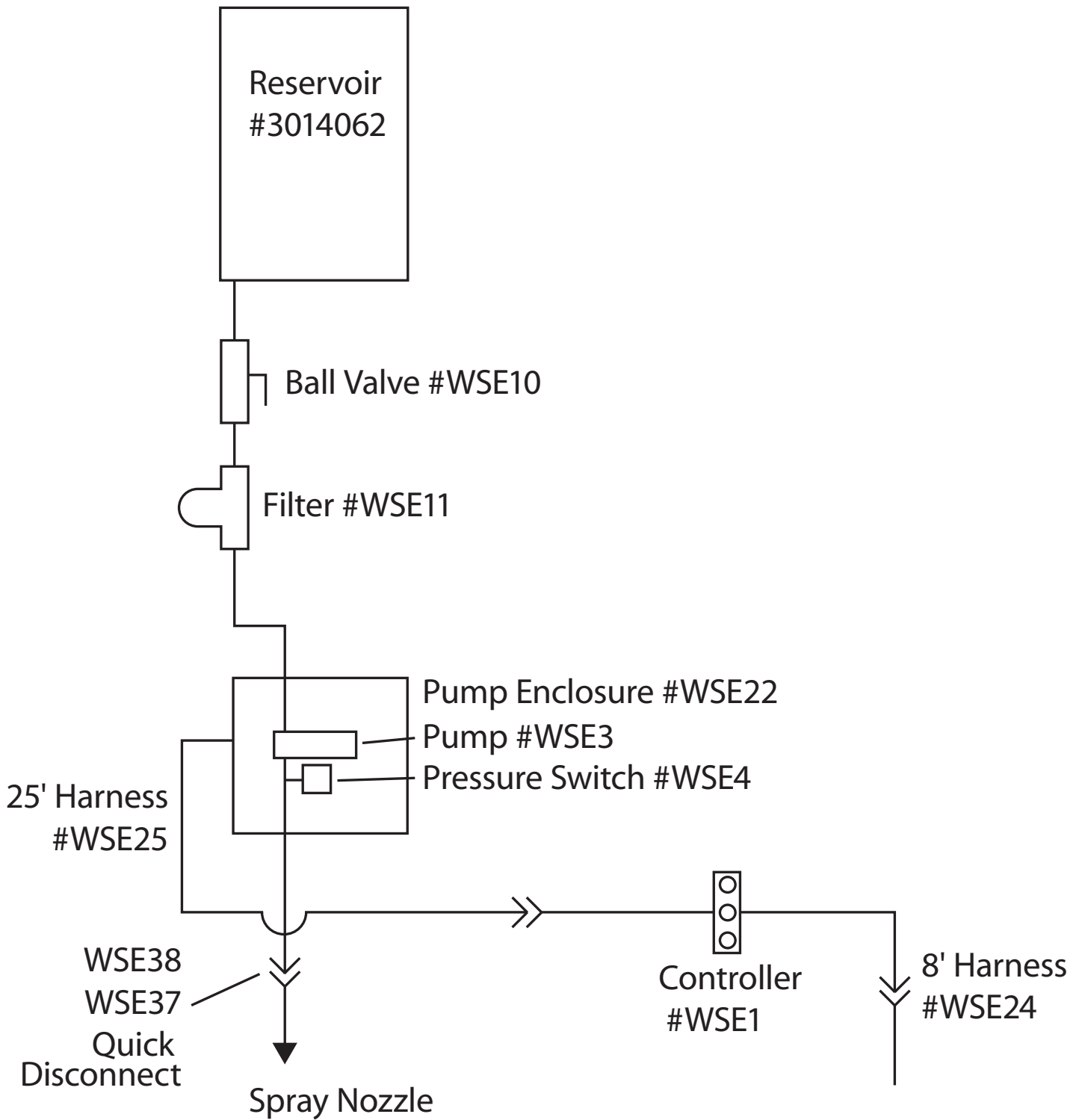

Fig. 6 Plumbing Dia.

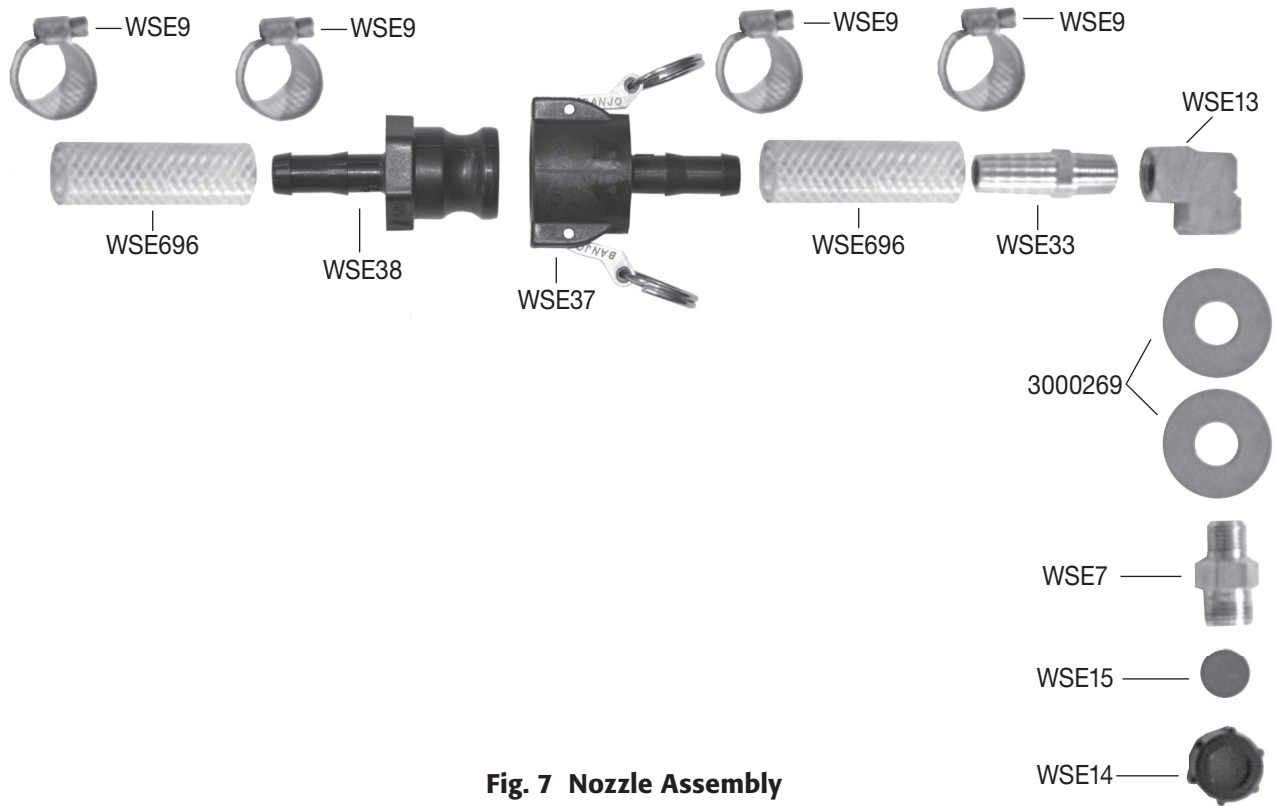

Fig. 7 Nozzle Assembly

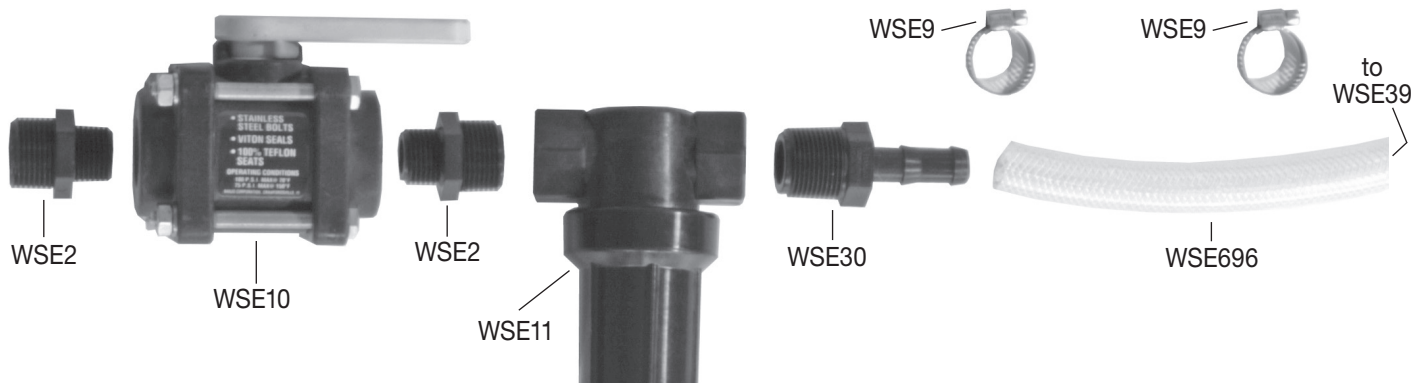

Fig. 8 Filter/Valve Assembly

Liquid Spray System Operating Instructions



1. Read all instructions before operating. Always wear hand, eye, and skin protection when working with de-icing chemicals. Make sure everyone is standing clear of liquid spray system before operating.
2. Inspect all plumbing for leaks.
3. Open ball valve (#WSE10) at the reservoir.
4. Make sure reservoir has adequate supply of clean de-icing liquid. Do not operate pump without liquid.
5. Before turning the cab controller on, turn the black speed control knob counter clockwise until it stops to set the pump at the slowest speed.
6. To energize system, turn red power button to illuminate LCD screen "on" position.
7. Increase pump speed to desired liquid spray application rate by turning black knob clockwise.
8. If the red low pressure warning light/alarm comes on, the reservoir is empty or the pump is off. Do not operate pump without liquid. Note: Low pressure light and alarm will sound each time system is started. This is normal and occurs until sufficient pressure is achieved to open pressure switch (turning off light/buzzer).
9. Close ball valve (#WSE10) at the reservoir when not in use.

Liquid Spray System Trouble Shooting Guide

Motor & Pump Operate Erratically: 1,2,3,4,5
 (Possible Problem)

Motor runs – Pump does not: 1,2,3,4,5,6,7 (Possible Problem)

Motor & Pump fail to operate: 8,9,10,11,12 (Possible Problem)

POSSIBLE PROBLEM:

- | | | |
|---|---------|-----------------|
| 1. Little or no de-icer in tank/s | REPAIR: | Fill |
| 2. Clogged filter | | Clean |
| 3. Clogged Nozzles | | Clean |
| 4. Damaged suction hose | | Replace |
| 5. Ruptured pump diaphragm | | Replace |
| 6. Ball valve is closed at tank/s | | Open valve |
| 7. Frozen parts | | Thaw out |
| 8. Bad electrical connection | | Inspect |
| 9. Motor failure- burned/seized | | Replace |
| 10. Cab controller on-off switch not turned on | | Turn on |
| 11. Bad cab controller on-off switch | | Replace |
| 12. Blown fuse in cab controller or fuse panel... | | Inspect/replace |



Always wear hand, eye, and skin protection when working with de-icing chemicals. Use extreme care!

Liquid Spray System Routine Maintenance

RESERVOIR:

- Inspect fittings for leaks from cracks or looseness
- Inspect filler/breather for cracks. Depress breather to check for adequate spring pressure or binding

PLUMBING:

- Inspect hoses/fittings/ball valve for leaks, cracks, looseness, chafing, binding etc.

FILTER:

- Remove and clean filter element every 8 to 10 hours or as needed depending on how clean de-icing liquid is

PUMP-PRESSURE SWITCH & ENCLOSURE:

- Inspect wiring for wear and loose or corroded connections
- Inspect door and gasket to prevent corrosion

NOZZLES:

- Inspect operation for even spray pattern. Remove and clean as needed

CAB CONTROLLER:

- Inspect lights, switch, and flow control knob
- Inspect wire harness and connections for wear and loose or corroded connections

CLEANING:

- Wash with hot water and soap after each use

STORAGE:

- Store inside to prevent freezing
- Drain liquid de-icer from tank/s and hoses when not in use for more than two days or during extremely low temperatures
- RV anti-freeze or windshield washer fluid should be run through the system for several minutes to flush de-icer from the system to prevent component freezing especially for end of season storage



-Always wear hand, eye, and skin protection when working with de-icing chemicals. Use extreme care!



Bill of Materials

PART NO.	QTY.	DESCRIPTION
3014062	1	Tank Poly 30 Gal Wet System w/Cap
3013939	1	Support Reservoir 30 Gal
3014065	4	Stop, Frame Wet System
-	4	Washer, Flat 3/8 USS SST
-	4	Nut, Nylock 3/8-16 x 7/16 SST
-	3	Screw, HH Cap 5/16-18 x 4 SST
-	3	Nut, Nylock 5/16-18 SS
-	6	Washer, 5/16 SAE SST
LS102	1	Enclosure ASM. Wetting System
3000269	2	Washer, Flat 1/2 USS, SST
WSE15	1	Rubber, Nozzle
149650501	2	Strap Assy, Ratchet 2" x 5'
3012164	1	Plug, Square Head, 3/4 NPT
WSE2	2	Nipple, Hex 3/4 x 1/2 Poly
WSE10	1	Valve Ball, 1/2 NPT, Polypropylene

PART NO.	QTY.	DESCRIPTION
WSE11	1	Filter, 3/4 NPT, 6 GPM, 300 Micron, Poly
WSE30	1	Barb, Hose 3/4 NPT x 1/2 HB
WSE9	6	Clamp, Hose
WSE696	2	Hose Poly 1/2 x 168 IN
WSE33	1	Barb, Hose 1/4 IN NPT x 1/2 IN Barb, Brass
WSE13	1	Elbow, Brass 1/4 IN NPT x 1/4 NPTF
WSE7	1	Nozzle Body, Brass
WSE14	1	Nozzle Cap
WSE1	1	Controller, Wet Spray System
WSE24	1	Harness, Wire w/Connector 8 Ft
WSE38	1	Cam Lock, Male x 1/2" Barb
WSE37	1	Cam Lock, Female x 1/2" Barb
3014110	1	Instruction Manual
3009750	1	Decal, Liquid System

SAFETY ALERT SYMBOL



This Symbol Means **ATTENTION!**
 Please Read & Understand Completely
 Before Operating!

EQUIPMENT INSTALLERS & OPERATORS:



TURN OFF ALL POWER BEFORE PERFORMING ANY SERVICE OPERATIONS.

- Follow Recommended Operating Procedure.
- Keep Equipment In Safe Operating Condition At All Times.
- Recognize & Avoid Hazards While Operating, Servicing and Maintaining Equipment.

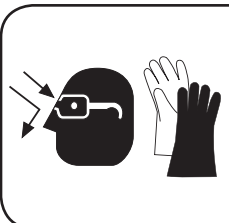

CAUTION

**RESERVOIR & COMPONENTS
 MAY CONTAIN HAZARDOUS
 MATERIAL.
 HANDLE WITH CARE.**

WARRANTY

Buyers Products Co. warrants all truck/trailer hardware manufactured or distributed by it, to be free from defects in material and workmanship for a period of one year from date of shipment. Parts must be properly installed and used under normal conditions. Any product which has been altered, including modification, misuse, accident or lack of maintenance will not be considered under warranty. Normal wear is excluded. The sole responsibility of Buyers Products Co. under this warranty is limited to repairing or replacing any part or parts which are returned, prepaid, and are found to be defective by Buyers Products Co. Authorization from Buyers Products Co. must be obtained before returning any part. No charges for transportation or labor performed on Buyers' products will be allowed under this warranty.



9049 Tyler Blvd. • Mentor, Ohio 44060
Phone (440) 974-8888 • Fax (440) 974-0165
Toll-Free Fax 800-841-8003 • saltdogg.com