

Installation & Operator's Manual

LS4T Tailgate Mounted Liquid Spray System

Installation Instructions

1. Using (8)3/8 x 1" Carriage Bolts and (8)3/8" Serrated Flange Nuts, attach the bottom two Crossmember Weldments to the Side Plates as shown in Figure 1.
2. Using (4)3/8 x 1" Carriage Bolts and (4)3/8" Serrated Flange Nuts, attach the Front (tailgate side) Crossmember Weldment to the Side Plates as shown in Figure 2.
3. Attach the Control Box Assembly to the driver side Side Plate using the predrilled holes and included hardware as shown in Figure 3.
4. Using (4)3/8 x 1" Carriage Bolts and (4)3/8" Serrated Flange Nuts, mount the (2) Top Bumper Brackets to the Side Plates as shown in Figure 4.
(Note: An alternate mounting position is available for angled tailgates.)
5. Position the Tank Assembly on the frame and fasten it in place using the (3) Ratchet Tie Downs. Then use (4)3/8 x 1" Carriage Bolts and (4)3/8" Serrated Flange Nuts to attach the last Crossmember Weldment to the assembly as shown in Figure 5.
6. Use a hoist, forklift, or other lifting aid to raise and position the assembled unit onto the tailgate of the dump body.
7. Using (4)3/8 x 1" Carriage Bolts and (4)3/8" Serrated Flange Nuts, mount the (2) Bottom Bumper Brackets to the Side Plates as shown in Figure 6. Using these brackets as templates, drill (4)5/16" diameter holes in the tailgate sheet. Position the Rubber Bumpers between the tailgate sheet and brackets then fasten in place using (4)1/4" x 1-3/4" HHCS & (4)1/4" Serrated Flange Nuts.
Note: Due to differences in tailgate designs, the provided hardware may not be the length you



- need. If necessary, purchase the correct length from your local hardware store. The hardware must be Grade 5 or higher.**
8. Plumb the system according to the plumbing schematic using the supplied fittings, hose, and hose clamps. See Figures 8, 9 and 10. **DO NOT use Teflon tape on threads as it will stretch and damage threads. Use liquid thread sealant only.**
 9. It is recommended to mount the nozzles so that the salt or other material is treated prior to contacting the spinner. Each nozzle requires an 11/16" diameter hole and you may need to fabricate mounts for them.

Fig. 1
Bottom Crossmembers & Side Plates

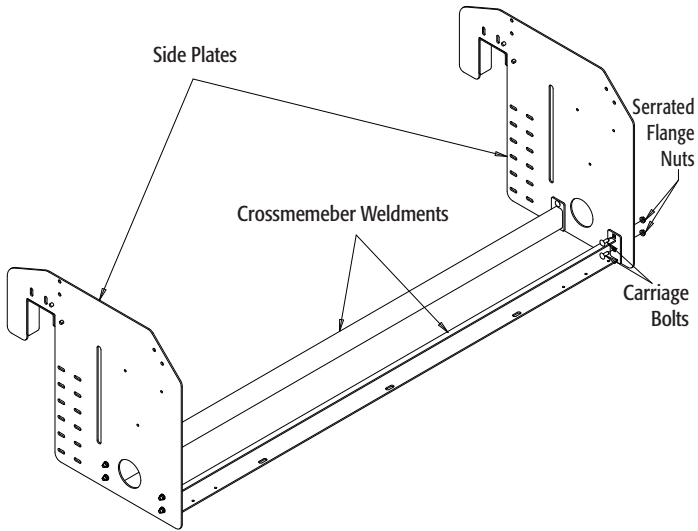

Fig. 2
Front Crossmember

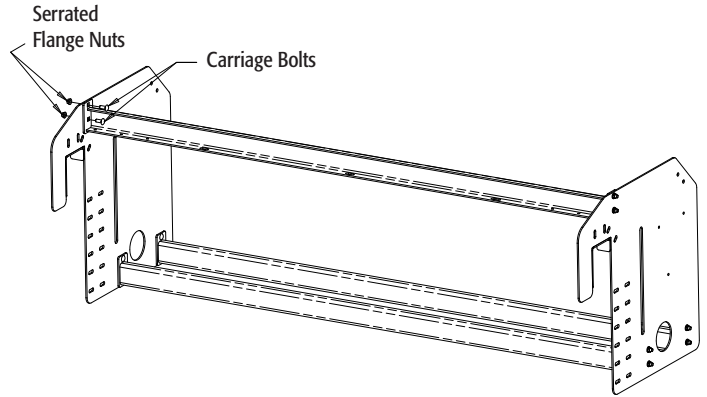

Fig. 3
Control Box

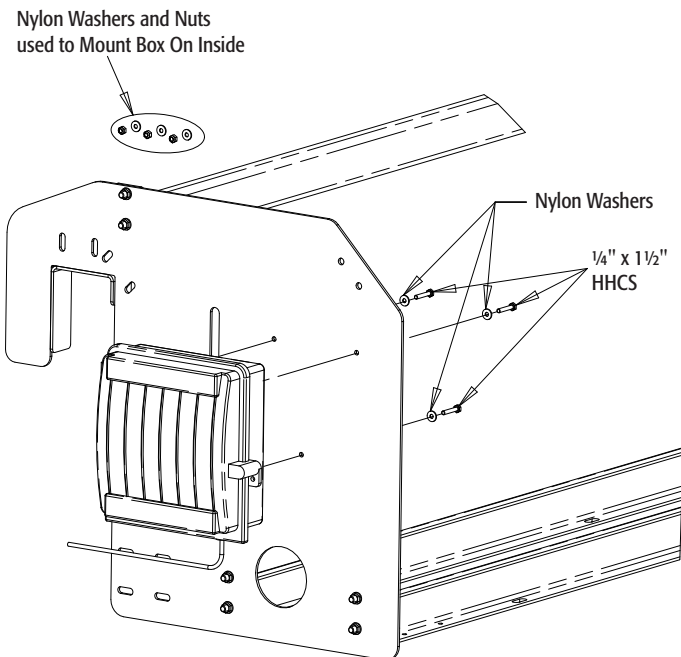
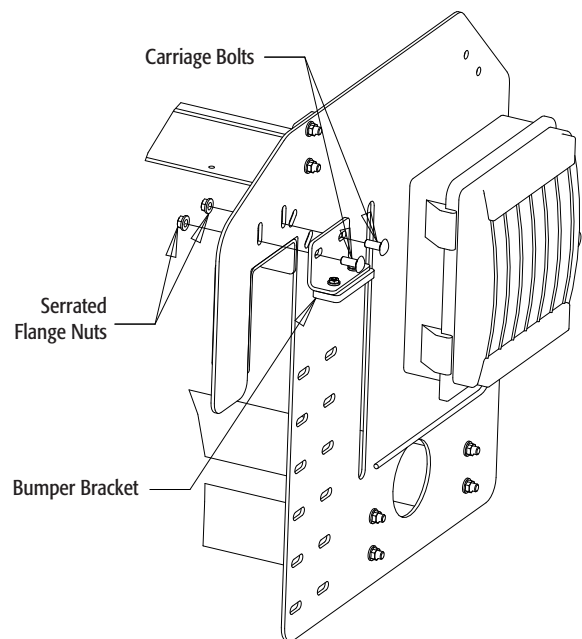

Fig. 4
Bumper Bracket



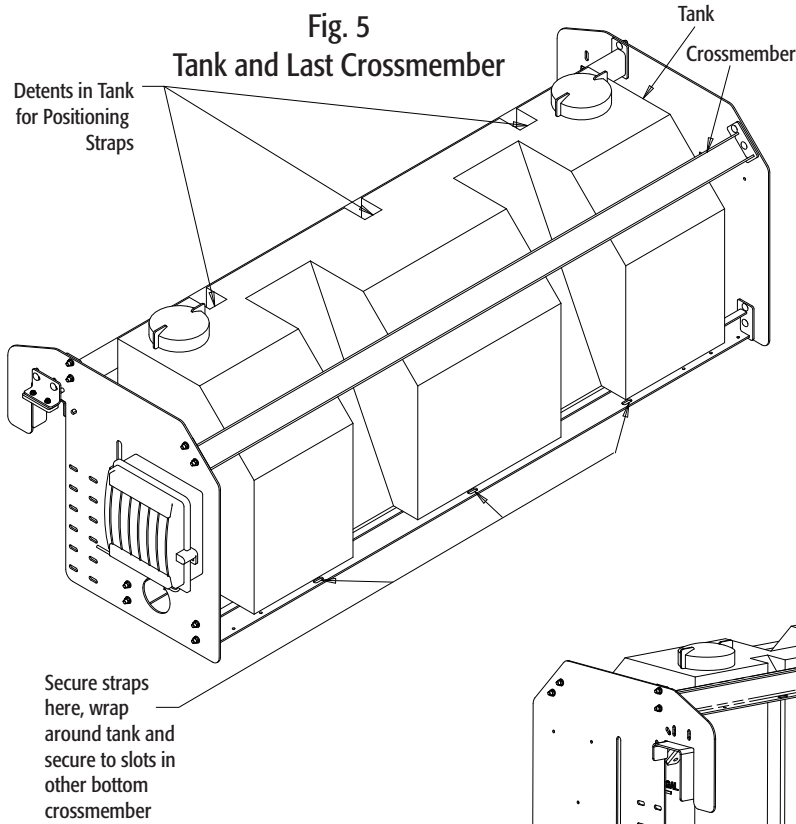
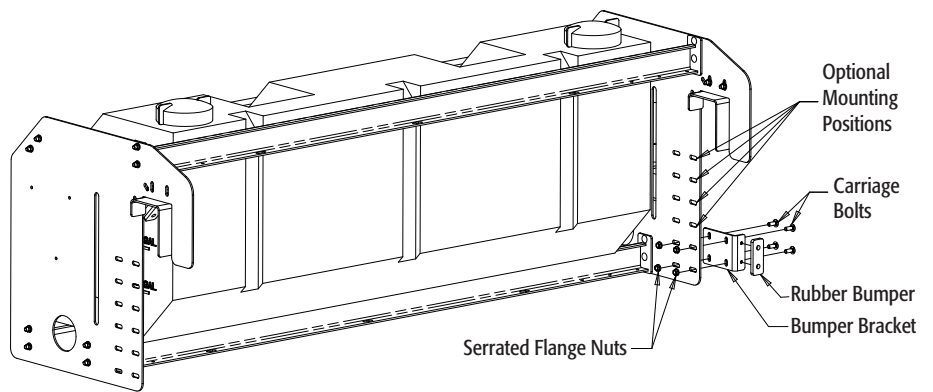

Fig. 6
 Bottom Tailgate Mounting Brackets



Cab Controller Installation

Instructions (Fig. 7)

- 1.** Install cab controller (#WSE1) in cab for convenient driver operation. Mounting bracket and fasteners included.
- 2.** Route 8' wire harness (#WSE24) under dash from controller (#WSE1) to truck's fuse panel.
- 3.** Ground "black" wire from controller to truck frame or truck's battery (not dash).
- 4.** Attach "green" wire in 8' wire harness (#WSE24) to a fused and keyed 15 Amp hot wire circuit.
- 5.** Connect main power "white" wire in 8' wire harness (#WSE24) to fuse box that is "hot" full time or to battery "positive".
- 6.** Route the 25' wire harness (#WSE25) from the rear of the spreader to the cab. Plug connector on controller (#WSE1) to the connector on pump harness (#WSE25).

Fig. 7 WSE1 Cab Controller



front view

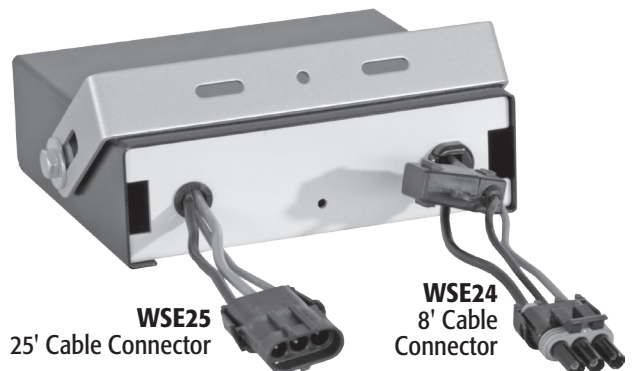

back view

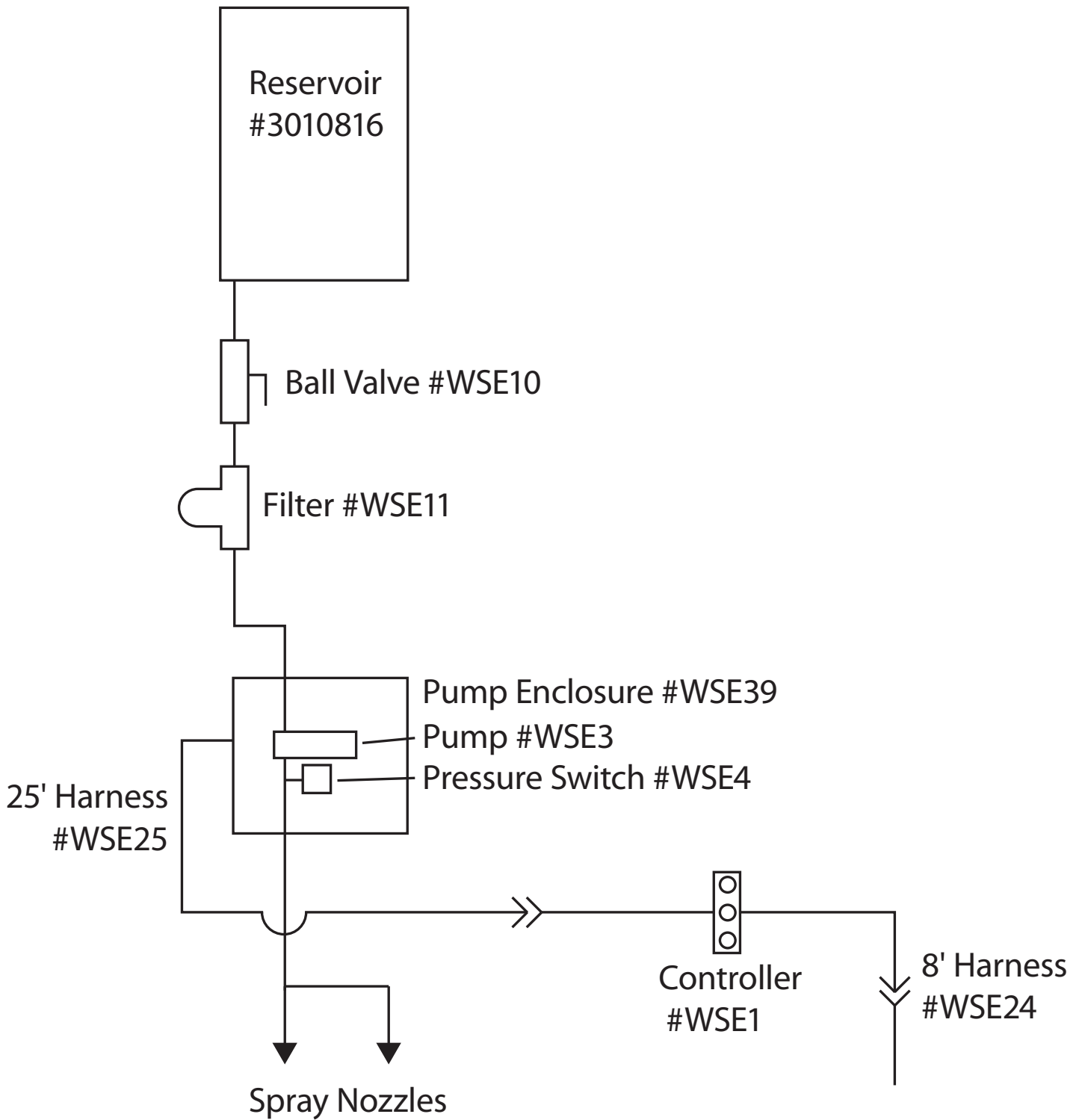

Fig. 8 Plumbing Dia.

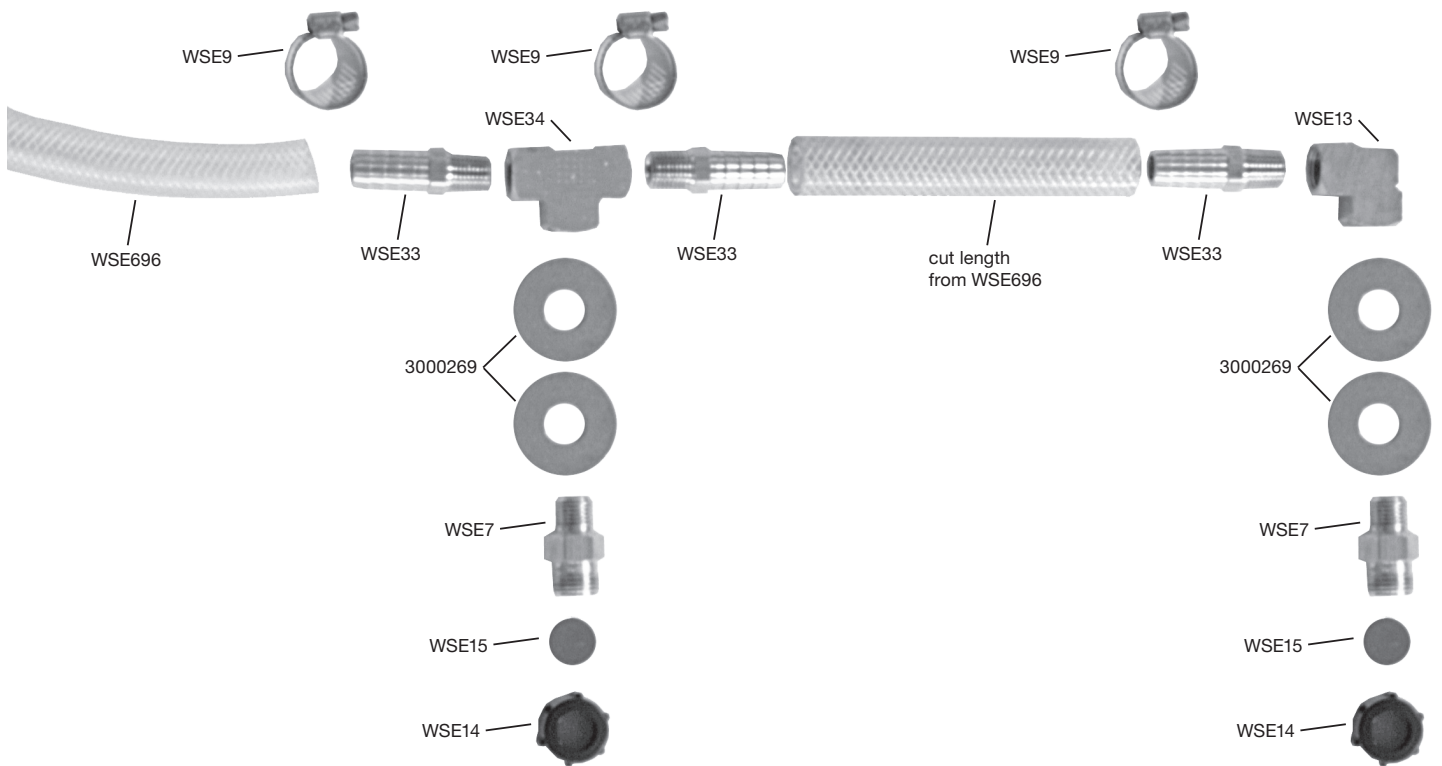

Fig. 9 Nozzle Assembly

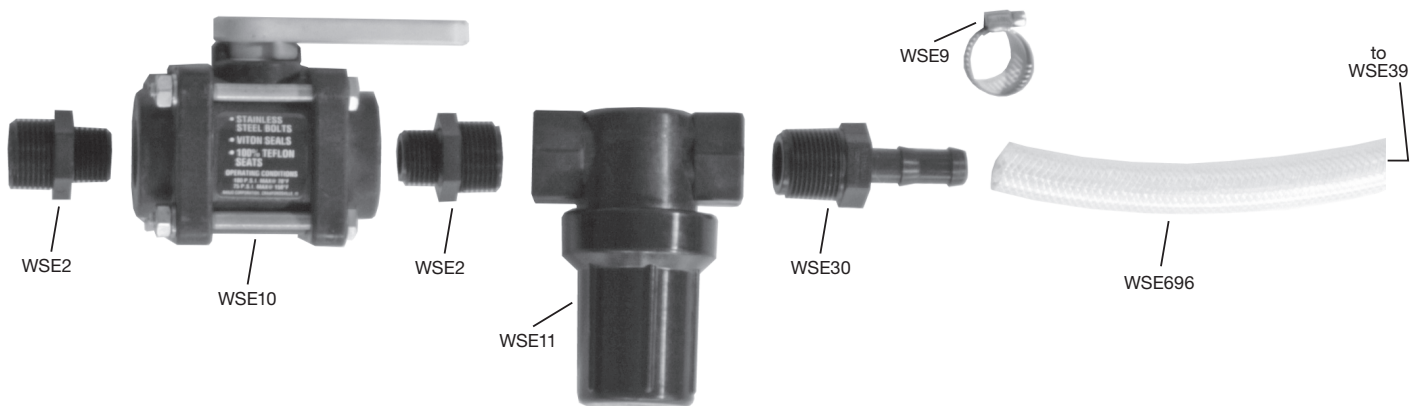

Fig. 10 Filter/Valve Assembly

Liquid Spray System Operating Instructions

1. Read all instructions before operating. Always wear hand, eye, and skin protection when working with de-icing chemicals. Make sure everyone is standing clear of liquid spray system before operating.
2. Inspect all plumbing for leaks.
3. Open ball valve (#WSE10) at the reservoir.
4. Make sure reservoir has adequate supply of clean de-icing liquid. Do not operate pump without liquid.
5. Before turning the cab controller on, turn the black speed control knob counter clockwise until it stops to set the pump at the slowest speed.
6. To energize system, turn red power button to illuminate LCD screen "on" position.
7. Increase pump speed to desired liquid spray application rate by turning black knob clockwise.
8. If the red low pressure warning light/alarm comes on, the reservoir is empty or the pump is off. Do not operate pump without liquid. Note: Low pressure light and alarm will sound each time system is started. This is normal and occurs until sufficient pressure is achieved to open pressure switch (turning off light/buzzer).
9. Close ball valve (#WSE10) at the reservoir when not in use.

Liquid Spray System Trouble Shooting Guide

- Motor & Pump Operate Erratically: 1,2,3,4,5 (Possible Problem)
- Motor runs – Pump does not: 1,2,3,4,5,6,7 (Possible Problem)
- Motor & Pump fail to operate: 8,9,10,11,12 (Possible Problem)

POSSIBLE PROBLEM:

REPAIR:

- | | |
|--|-----------------|
| 1. Little or no de-icer in tank/s | Fill |
| 2. Clogged filter | Clean |
| 3. Clogged Nozzles | Clean |
| 4. Damaged suction hose | Replace |
| 5. Ruptured pump diaphragm | Replace |
| 6. Ball valve is closed at tank/s | Open valve |
| 7. Frozen parts | Thaw out |
| 8. Bad electrical connection..... | Inspect |
| 9. Motor failure- burned/seized..... | Replace |
| 10. Cab controller on-off switch not turned on | Turn on |
| 11. Bad cab controller on-off switch..... | Replace |
| 12. Blown fuse in cab controller or fuse panel..... | Inspect/replace |

Liquid Spray System Routine Maintenance

Reservoir:

- Inspect fittings for leaks from cracks or looseness
- Inspect filler/breather for cracks. Depress breather to check for adequate spring pressure or binding

Plumbing:

- Inspect hoses/fittings/ball valve for leaks, cracks, looseness, chafing, binding etc.

Filter:

- Remove and clean filter element every 8 to 10 hours or as needed depending on how clean de-icing liquid is

Pump-Pressure Switch & Enclosure:

- Inspect wiring for wear and loose or corroded connections
- Inspect door and gasket to prevent corrosion

Nozzles:

- Inspect operation for even spray pattern. Remove and clean as needed

Cab Controller:

- Inspect lights, switch, and flow control knob
- Inspect wire harness and connections for wear and loose or corroded connections

Cleaning:

- Wash with hot water and soap after each use

Storage:

- Store inside to prevent freezing
- Drain liquid de-icer from tank/s and hoses when not in use for more than two days or during extremely low temperatures
- RV anti-freeze or windshield washer fluid should be run through the system for several minutes to flush de-icer from the system to prevent component freezing especially for end of season storage

 **CAUTION**

Always wear hand, eye, and skin, protection when working with de-icing chemicals. Use extreme care!

Bill of Materials

PART NO.	QTY.	DESCRIPTION
-	4	WASHER,FLAT 1/2 X 1-3/8" OD STAINLESS
-	28	3/8" SERRATED FLANGE NUTS
3009750	1	DECAL,LIQUID SYSTEM
3010816	1	RESERVOIR, 105 GALLON
3012164	1	PLUG, SQUARE HEAD, 3/4NPT
-	28	BOLT,CARRIAGE SHORT NECK 3/8-16X1.0,SST
3015804	2	BOTTOM BUMPER BRACKET
3015805	2	TOP BUMPER BRACKET
3015809	4	CROSSMEMBER WELDMENT
3015813	1	INSTRUCTION MANUAL, LS4T
3015814	4	RUBBER BUMPER
3015827	2	SIDE PLATE
149650501	3	STRAP,SPREADER HOLD DOWN (ONE ONLY)
CT10BX	1	BOX,17-1/4 X 13-1/2 X 17-1/4
LS102	1	ENCLOSURE ASSEMBLY, WETTING SYSTEM, ELECTRIC

PART NO.	QTY.	DESCRIPTION
WSE1	1	CONTROLLER, WET SYSTEM SPRAY
WSE10	1	VALVE,BALL POLYPROPYLENE
WSE11	1	FILTER
WSE13	1	ELBOW,BRASS 1/4NPTF X 1/4NPTF
WSE14	2	NOZZLE CAP
WSE15	2	RUBBER NOZZLE
WSE2	2	NIPPLE, HEX 3/4 X 1/2 POLY
WSE24	1	HARNESS,WIRE WITH CONNECTOR 8' POWER
WSE30	1	BARB HOSE 3/4 NPT X 1/2 HB
WSE33	3	BARB HOSE 1/4" NPT X 1/2" ID
WSE34	1	TEE,FEMALE BRANCH 1/4 X 1/4 X 1/4
WSE696	1	HOSE, POLY 1/2 ID X 96"
WSE7	2	NOZZLE BODY, BRASS
WSE9	6	CLAMP, HOSE

SAFETY ALERT SYMBOL



This Symbol Means **ATTENTION!**
 Please Read & Understand Completely
 Before Operating!

EQUIPMENT INSTALLERS & OPERATORS:



TURN OFF ALL POWER BEFORE PERFORMING ANY SERVICE OPERATIONS.

- Follow Recommended Operating Procedure.
- Keep Equipment In Safe Operating Condition At All Times.
- Recognize & Avoid Hazards While Operating, Servicing and Maintaining Equipment.

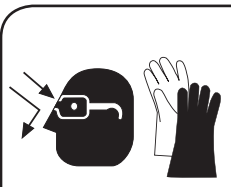

CAUTION

**RESERVOIR & COMPONENTS
 MAY CONTAIN HAZARDOUS
 MATERIAL.
 HANDLE WITH CARE.**

WARRANTY

Buyers Products Co. warrants all truck/trailer hardware manufactured or distributed by it, to be free from defects in material and workmanship for a period of one year from date of shipment. Parts must be properly installed and used under normal conditions. Any product which has been altered, including modification, misuse, accident or lack of maintenance will not be considered under warranty. Normal wear is excluded. The sole responsibility of Buyers Products Co. under this warranty is limited to repairing or replacing any part or parts which are returned, prepaid, and are found to be defective by Buyers Products Co. Authorization from Buyers Products Co. must be obtained before returning any part. No charges for transportation or labor performed on Buyers' products will be allowed under this warranty.

