

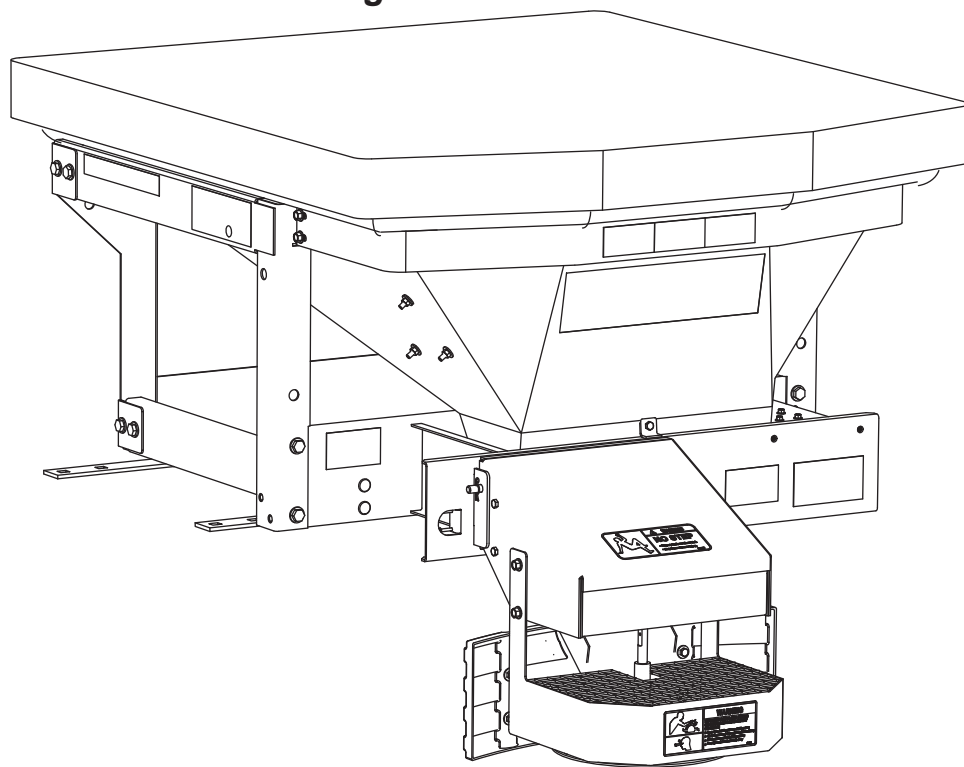

UTV Hopper Spreader

#SP-2000

Owner's Manual
Original Instructions



⚠ CAUTION

Read this manual before installing or operating the spreader.

This manual is for SnowEx® UTV hopper spreaders with serial numbers 160901 and higher.

This document supersedes all editions with an earlier date.

TABLE OF CONTENTS

PREFACE	5	MAINTENANCE	16
Owner's Information.....	5	Lubrication	16
SAFETY INFORMATION	6	After Each Use.....	16
Safety Definitions.....	6	Storage	16
Warning/Caution Labels	6	At the End of Each Season or	
Serial Number Label	7	After Extended Storage.....	16
Safety Precautions.....	8	TROUBLESHOOTING GUIDE	17
Personal Safety.....	8		
Fire and Explosion.....	9		
Cell Phones.....	9		
Ventilation	9		
Battery Safety	9		
LOADING	10		
Material Weights	10		
Certification.....	10		
Determining Vehicle Payload.....	11		
MOUNTING THE SPREADER	12		
OPERATING THE SPREADER – CAB CONTROL .	14		
Starting and Stopping Motor.....	14		
Adjusting Auger/Spinner Speed.....	14		
Spreading Tips.....	14		
Auto-Reverse "AR" Feature.....	15		

PREFACE

This manual has been prepared to acquaint you with the safety information, operation and maintenance of your new hopper spreader. Please read this manual carefully and follow all recommendations. This will help ensure profitable and trouble-free operation of your hopper spreader. Keep this manual accessible. It is a handy reference in case minor service is required.

When service is necessary, bring your hopper spreader to your distributor. They know your spreader best and are interested in your complete satisfaction.

NOTE: This spreader is designed to spread snow and ice control materials only. Do not use it for purposes other than those specified in this manual.

Register your spreader online at www.snowexproducts.com

OWNER'S INFORMATION

Owner's Name: _____

Date Purchased: _____

Outlet Name: _____ Phone: _____

Outlet Address: _____

Vehicle Model: _____ Year: _____

Spreader Type (Model): _____ Serial #: _____

Length: _____ Weight: _____ lb/kg: _____

SAFETY INFORMATION

SAFETY DEFINITIONS

⚠ WARNING

Indicates a potentially hazardous situation that, if not avoided, could result in death or serious personal injury.

⚠ CAUTION



Indicates a potentially hazardous situation that, if not avoided, may result in minor or moderate injury. It may also be used to alert against unsafe practices.

NOTE: Indicates a situation or action that can lead to damage to your spreader and vehicle or other property. Other useful information can also be described.

WARNING/CAUTION LABELS

Please become familiar with the Warning and Caution labels on the spreader.

NOTE: If labels are missing or cannot be read, see your sales outlet.

⚠ WARNING	
	
<ul style="list-style-type: none"> • DO NOT EXCEED GVWR OF VEHICLE • DO NOT OVERLOAD SPREADER • LOAD SPREADER EVENLY 	
D6546	

⚠ WARNING

<p>NO STEP</p> <ul style="list-style-type: none"> • Slippery Surface When Wet. • May Cause Severe Injury
D6545

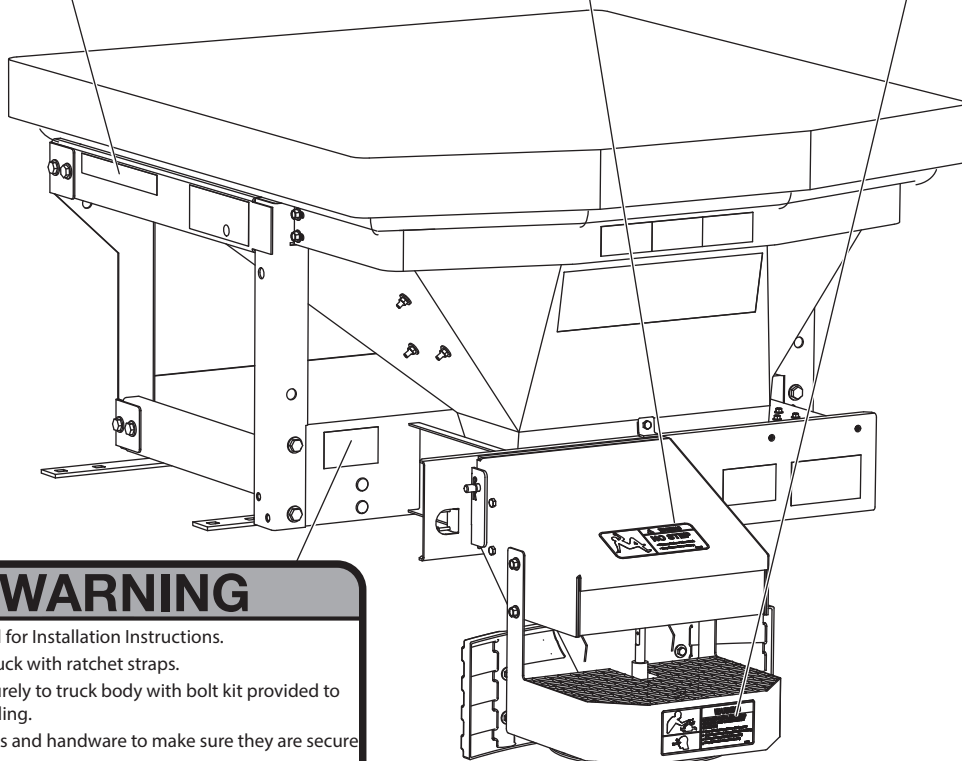
⚠ WARNING

<p>ROTATING PARTS AND FLYING OBJECTS CAN CAUSE INJURY OR DEATH</p> <ul style="list-style-type: none"> • Keep hands, arms, feet and loose clothing away • Shut off power and stop engine before servicing • Read owners manual before operating. • Keep bystanders at least 60 ft away.
D6544

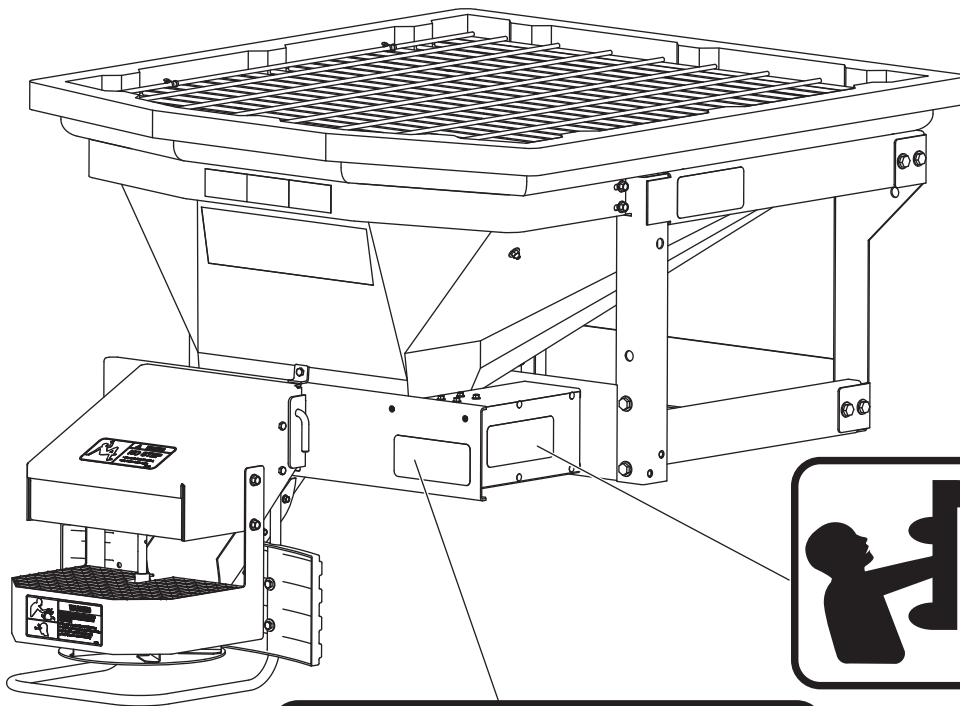

⚠ WARNING
<ul style="list-style-type: none"> • Read Owner's Manual for Installation Instructions. • Secure spreader to truck with ratchet straps. • Anchor spreader securely to truck body with bolt kit provided to prevent slipping or sliding. • Routinely check straps and hardware to make sure they are secure
D6548

SAFETY INFORMATION



⚠ WARNING

ROTATING AUGER CAN CAUSE SERIOUS INJURY OR DEATH

- Keep arms, hands, and loose clothing away from auger.
- Shut off control and unplug spreader before servicing.

D6335

DANGER

- DO NOT REMOVE SPREADER WITH MATERIAL IN HOPPER
- FASTEN SPREADER DOWN WITH APPROVED RATCHET STRAPS AND BOLT KIT
- REAR FRAME LOCATOR BARS MUST BE IN PLACE BEFORE OPERATING VEHICLE

D6547

SERIAL NUMBER LABEL

MODEL NO. SERIAL NO.

11 cu ft **YYMMDD####PPPPP**

Code	Definition
YY	2-Digit Year
MM	2-Digit Month
DD	2-Digit Day
####	4-Digit Sequential Number
PPPPP	5-Digit Assembly PN

SAFETY INFORMATION

SAFETY PRECAUTIONS

Improper installation and operation could cause personal injury and/or equipment and property damage. Read and understand labels and the Owner's Manual before installing, operating or making adjustments.

⚠ WARNING

- Driver to keep bystanders minimum of 25 feet away from operating spreader.
- Before working with the spreader, secure all loose-fitting clothing and unrestrained hair.
- Before operating the spreader, verify all safety guards are in place.
- Before servicing the spreader, wait for auger and spinner to stop.
- Do not climb into or ride on spreader.

⚠ WARNING



Overloading could result in an accident or damage. Do not exceed GVWR of UTV. See Loading Section to determine maximum volumes of spreading material.

⚠ CAUTION

- Do not operate a spreader in need of maintenance.
- Before operating the spreader, reassemble any parts or hardware removed for cleaning or adjusting.
- Before operating the spreader, remove materials such as cleaning rags, brushes, and hand tools from the spreader.
- While operating the spreader, use auxiliary warning lights, except when prohibited by law.

⚠ CAUTION

Disconnect electric and/or hydraulic power and tag out if required before servicing or performing maintenance.

⚠ CAUTION



DO NOT leave unused material in hopper. Material can freeze or solidify, causing unit to not work properly. Empty and clean after each use.

NOTE: Lubricate grease fittings after each use. Use a good quality multipurpose grease.

PERSONAL SAFETY

- Remove ignition key and put the vehicle in park or in gear to prevent others from starting the UTV during installation or service.
- Wear only snug-fitting clothing while working on your vehicle or spreader.
- Do not wear jewelry or a necktie, and secure long hair.
- Wear safety goggles to protect your eyes from battery acid, gasoline, dirt and dust.
- Avoid touching hot surfaces such as the engine, radiator, hoses and exhaust pipes.
- Always have a fire extinguisher rated BC handy, for flammable liquids and electrical fires.

SAFETY INFORMATION

FIRE AND EXPLOSION

⚠ WARNING

Gasoline is highly flammable and gasoline vapor is explosive. Never smoke while working on vehicle. Keep all open flames away from gasoline tank and lines. Wipe up any spilled gasoline immediately.

Be careful when using gasoline. Do not use gasoline to clean parts. Store only in approved containers away from sources of heat or flame.

CELL PHONES

A driver's first responsibility is the safe operation of the vehicle. The most important thing you can do to prevent a crash is to avoid distractions and pay attention to the road. Wait until it is safe to operate Mobile Communication Equipment such as cell phones, text messaging devices, pagers or two-way radios.

VENTILATION

⚠ WARNING

Vehicle exhaust contains lethal fumes. Breathing these fumes, even in low concentrations, can cause death. Never operate a vehicle in an enclosed area without venting exhaust to the outside.

BATTERY SAFETY

⚠ CAUTION

Batteries normally produce explosive gases which can cause personal injury. Therefore, do not allow flames, sparks or lit tobacco to come near the battery. When charging or working near a battery, always cover your face and protect your eyes, and also provide ventilation.

- Batteries contain sulfuric acid which burns skin, eyes and clothing.
- Disconnect the battery before removing or replacing any electrical components.

LOADING

This Manual covers vehicles which have been recommended for carrying the hopper spreader. Please see your local dealer for proper vehicle applications.

⚠ WARNING

Overloading could result in an accident or damage. Do not exceed GVWR of UTV.

MATERIAL WEIGHTS



⚠ CAUTION

Read and adhere to manufacturer's ice-control material package labeling including Material Safety Data Sheet requirements.

LOADING

DETERMINING VEHICLE PAYLOAD

⚠ WARNING

Overloading could result in an accident or damage. Do not exceed GVWR of UTV. See Loading Section to determine maximum volumes of spreading material.

1. Install the hopper spreader and optional equipment according to the instructions.
2. Install or attach any other equipment that will be on the vehicle while the hopper spreader will be in use (step bumper, trailer hitch, snowplows, etc.). Fill gas tanks.
3. Obtain the Gross Vehicle Weight Rating (GVWR) from the UTV manufacturer.
4. With the occupants in the truck for normal hopper spreader operation, weigh the vehicle to obtain gross vehicle weight (GVW).
5. Subtract the GVW from the GVWR to determine the available material payload.
6. Obtain the weight per cubic yard (lb/cu yd) of the desired material. Divide the weight into the payload to determine the maximum volume of material that can be carried.

7. Compare the maximum volume to determine the maximum height of the material in the hopper spreader.
8. Fill the hopper with the material to the calculated height. Reweigh the vehicle with occupants and verify the GVW, Front Gross Axle Weight and Rear Gross Axle Weight are less than the vehicle's ratings.
9. Repeat Steps 7 and 8 for each type of material.

⚠ WARNING

Do not overload vehicle. Use chart below to calculate weight of material. Weights of material are an average for dry materials.

⚠ CAUTION

Never use wet materials or materials with foreign debris with any of these spreaders. These units are designed to handle dry, clean, free flowing material.

Material	Density (lb/ft³)
Rock Salt – Dry	80–90
Sand/Salt Mix – Dry	95–120

MOUNTING SPREADER

MOUNTING SPREADER

NOTE: Periodically throughout the snow and ice control season, verify mounting devices are secure.

⚠ WARNING

Spreader shall be bolted to vehicle frame. Do not rely on the tie-down chains or straps alone to hold spreader in vehicle.

⚠ CAUTION

Before lifting, verify hopper is empty of material. The lifting device must be able to support the spreader's weight as shown in the spreader specifications table.

1. Remove the tailgate from the pickup bed.
2. Load the spreader onto the truck bed.
3. Mount the chute to the deflector using the supplied hardware kit.

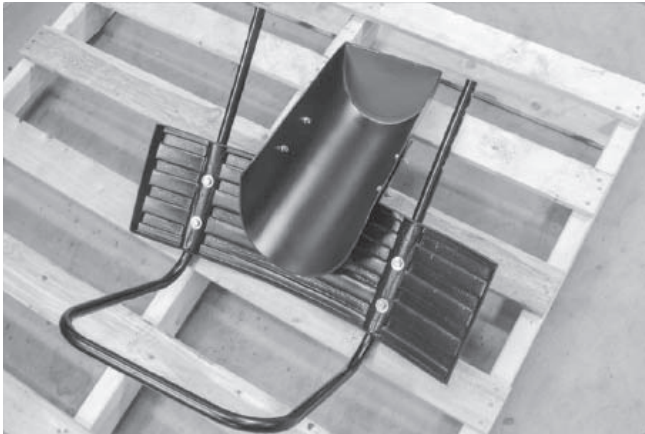

4. Mount the chute/deflector assembly to the spinner assembly with supplied hardware to form the drive assembly.



5. Mount the drive assembly to the spreader with a bent pin and secure with a hair pin cotter. Ensure that pin passes through the tab in the center.
6. Slide the spreader forward until the deflector/chute assembly makes contact with the vehicle. Then, slide spreader back approximately 1" to allow proper clearance.

MOUNTING SPREADER

7. Once the spreader is positioned front to back, center it left to right. Looking at the inside corners of the lower frame area, you will notice four holes in the bottom of the frame. Using a paint pen or similar marking device, mark hole locations.

⚠ CAUTION

Before drilling holes, check to be sure that no vehicle wiring or other components could be damaged.

8. If the marked hole locations will not work, install the optional bolting bars to the spreader using 1/2" carriage bolts and hardware. Mark the new hole locations. Drill 1/2" holes at the marked locations.

9. Install and tighten all four cap screws.

10. Install the four ratchet straps as shown below.

NOTE: It is important for safety that this strapping method be used as the standard mounting procedure.

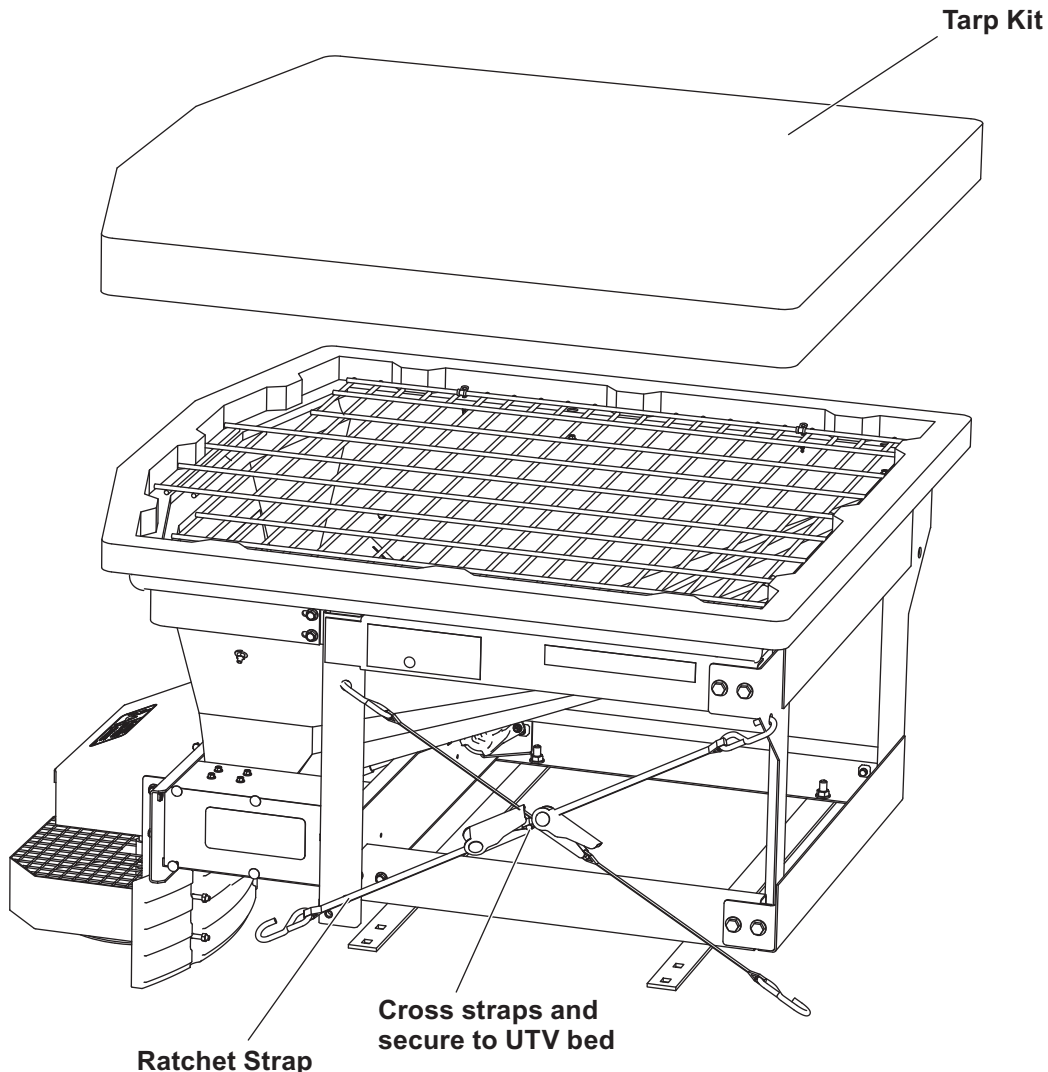

OPERATING THE SPREADER – CAB CONTROL

⚠ WARNING

Never operate equipment when under the influence of alcohol, drugs, or medications that might alter your judgment and/or reaction time.

⚠ WARNING

Never exceed 45 mph (72 km/h) when loaded spreader is attached to vehicle. Braking distances may be increased and handling characteristics may be impaired at speeds above 45 mph (72 km/h).

⚠ WARNING

Never allow children to operate or climb on equipment.

STARTING AND STOPPING MOTOR

1. To start the spreader, press the POWER switch to ON position on the control.
2. Press the POWER switch to the OFF position to stop the spreader. Speed of Auger and Spinner may be adjusted separately to get desired flow and spread distance.

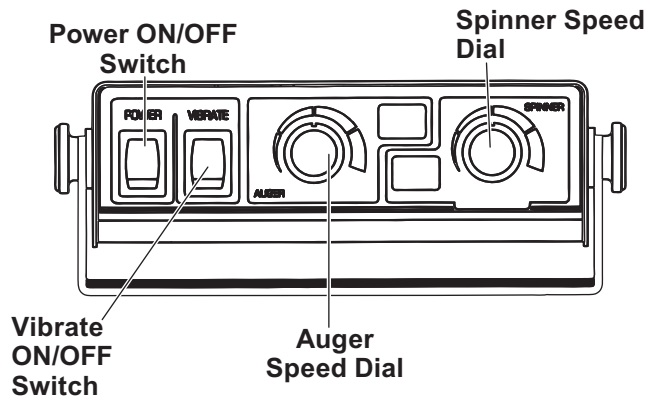

NOTE: The UTV ignition must be ON to start the spreader.

NOTE: If UTV ignition is turned OFF while spreader is running, the motors will stop.

ADJUSTING AUGER/SPINNER SPEED

1. Turn speed dial clockwise to increase speed. When POWER switch is set to ON position, the spreader will accelerate to speed set on spinner and auger dials.
2. Turning speed dial counterclockwise will decrease speed.

NOTE: Always use the tarp kit on the hopper to prevent moisture buildup. Do not let spreader sit idle with material in the hopper for an extended period of time. This can cause material to compact, reduce or stop the flow of material and cause permanent hopper body deformation.

NOTE: The Vibrator Switch is needed for dense material or to increase the flow to the Auger. This eliminates bridging of material in hopper.

NOTE: A Material Baffle has been installed in your spreader to stop fine material from free flowing. If using dense or damp material, or if more flow is desired, remove Material Baffle. However, it is recommended that the Material Baffle remain in place if using bulk salt.

OPERATING THE SPREADER – CAB CONTROL

SPREADING TIPS

- Spread ice melters with the storm to prevent unmanageable levels of ice.
- Never exceed 10 mph (16 km/h) when spreading.
- For a wider pass, increase spinner speed.
- For a heavier pass, drive slower or increase auger speed.
- Never operate spreader near pedestrians
- Calculate spread pattern when near vegetation.

ACCESSORIES

The following accessories are available from your distributor:

Optimum Flow Kit

The optimum flow kit improves material flow and allows spreading of a 50/50 salt/sand mix with a vibrator and dual pitch baffle.

Auger Tube Restrictor Kit

The auger tube restrictor kit prevents leaking issues when handling fine pellet and flake materials.

AUTO-REVERSE "AR" FEATURE

1. If your control displays "OL" this could indicate a jammed auger
2. Switch OFF the main power for 3 seconds.
3. Switch the Main Power ON. When the machine starts to back up the "AR" sequence will automatically start and the auger will reverse for several rotations to clear the jam.
4. After a pause of several moments, the auger will automatically return to correct rotation.
5. If the jam is still not cleared, the control will again display "OL" code.
6. You may repeat Steps 2 and 3 for a second and third time.
7. If after the third attempt the control displays "OL" code, you **must** extract the material that is causing the problem.
8. Follow all safety instructions when clearing jams.

MAINTENANCE

⚠ WARNING

Never remove spreader with material in hopper.

⚠ CAUTION

Disconnect electric power at spreader electrical wiring harness connection and tag out if required before servicing or performing maintenance.

⚠ CAUTION

- When replacing parts use only original manufacturer's parts. Failure to do so will void warranty.
- The control is a solid state electronic unit and is not serviceable. Any attempt to service will void warranty.
- There are no serviceable parts in the motor/transmission assembly. Any attempt to service will void warranty.
- Spinner motor is not designed for continuous duty. Allow motor to cool between long cycle times.
- When pressure washing motor enclosure area, stay at least 36" away from motor enclosures.

LUBRICATION

To keep your spreader running smoothly, observe the following recommendations:

- Lubricate bearings after every 20 hours of use.

AFTER EACH USE

- Wash out the hopper and rinse off all external surfaces.
- Apply dielectric grease on all electrical connections to prevent corrosion.

STORAGE

Store control in a cool dry place during the off season.

At the End of Each Season or After Extended Storage

- Wash out the hopper and rinse off all external surfaces.
- Apply dielectric grease on all electrical connections to prevent corrosion.
- Lubricate all grease fittings with good quality multipurpose grease.
- Oil or paint all bare metal surfaces.
- If motor cover is removed for any reason, use silicone sealant to ensure weather proofing of enclosure.
- After first use, tighten all fasteners on spreader and mount.

TROUBLESHOOTING GUIDE

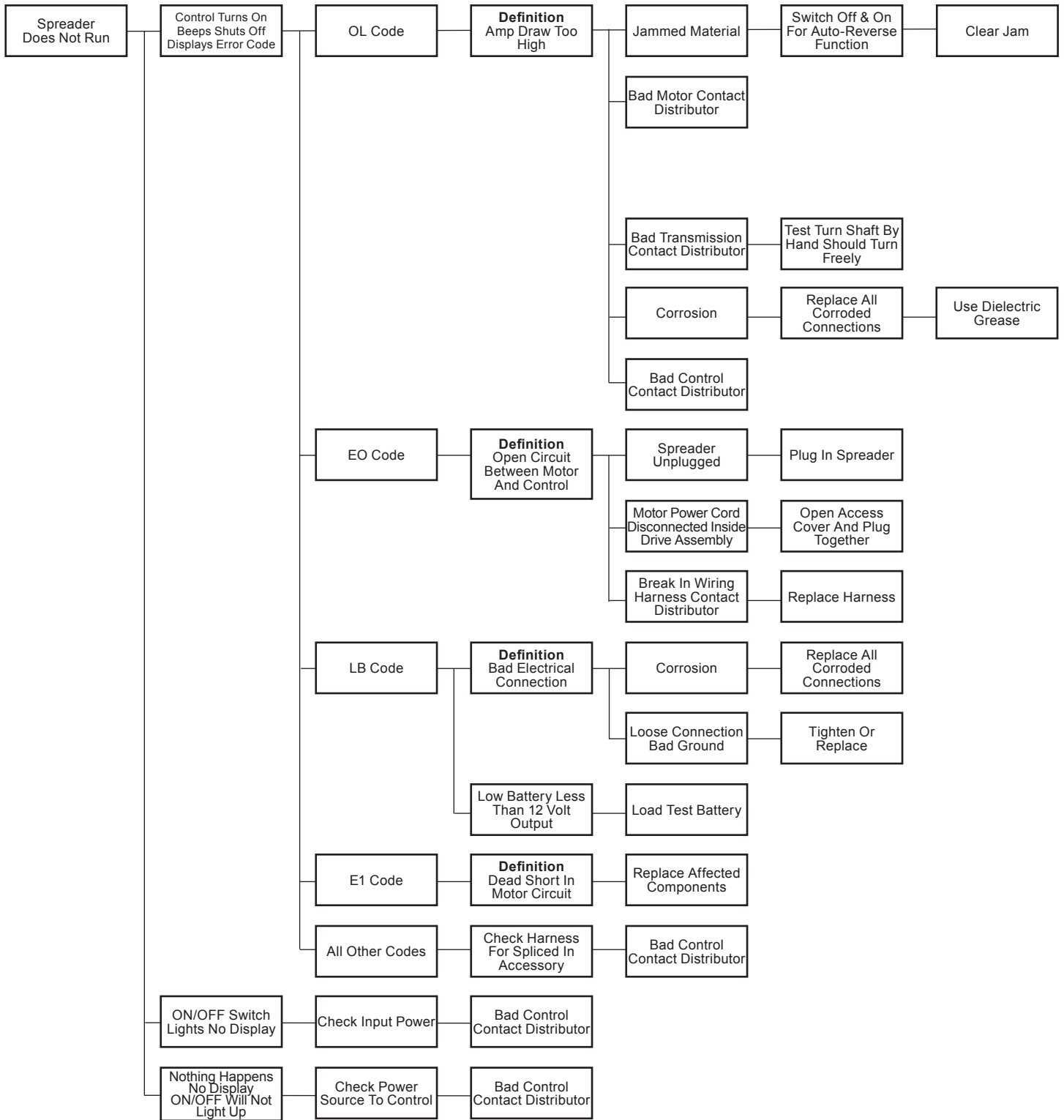

TROUBLESHOOTING GUIDE

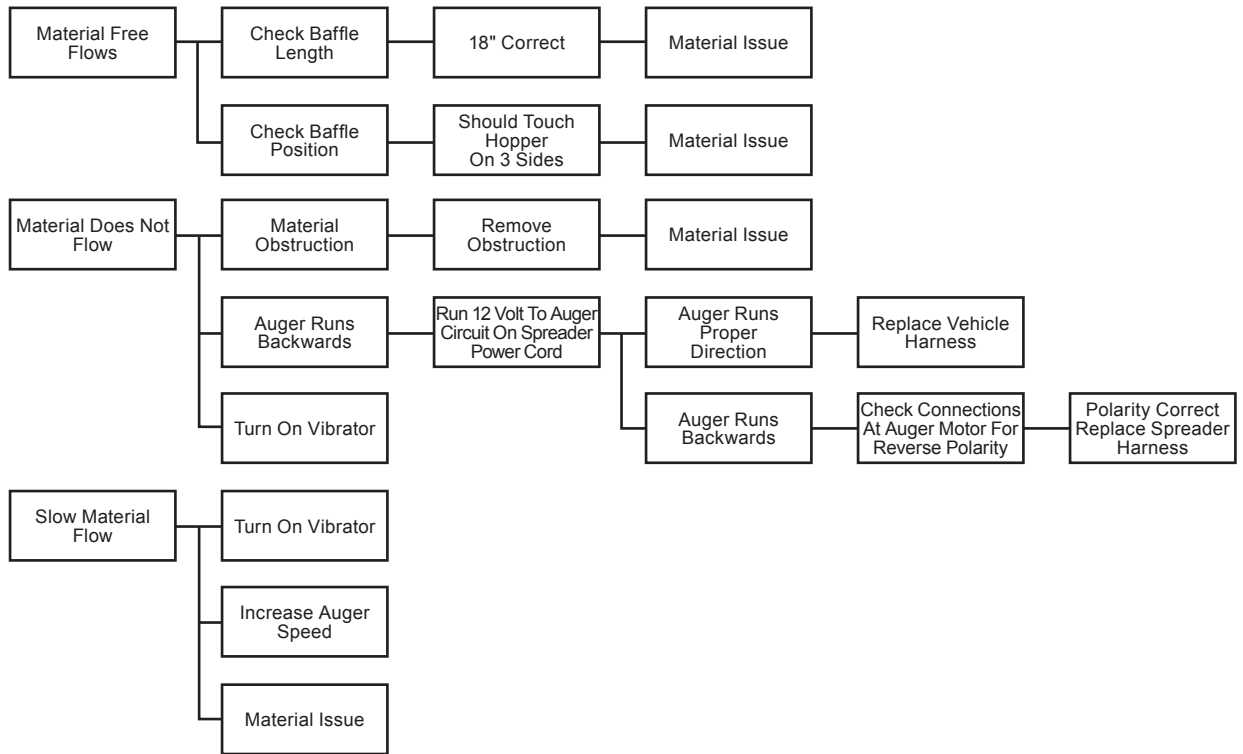



TrynEx International
531 Ajax Drive
Madison Heights, MI 48071-2429
www.snowexproducts.com

 A DIVISION OF DOUGLAS DYNAMICS, LLC

Copyright © 2016 Douglas Dynamics, LLC. All rights reserved. This material may not be reproduced or copied, in whole or in part, in any printed, mechanical, electronic, film or other distribution and storage media, without the written consent of TrynEx International. Authorization to photocopy items for internal or personal use by TrynEx International outlets or spreader owner is granted.

TrynEx International reserves the right under its product improvement policy to change construction or design details and furnish equipment when so altered without reference to illustrations or specifications used. TrynEx International or the vehicle manufacturer may require or recommend optional equipment for spreaders. Do not exceed vehicle ratings with a spreader. TrynEx International offers a limited warranty for all spreaders and accessories. See separately printed page for this important information. The following are registered (®) trademarks of Douglas Dynamics, LLC: SnowEx®, TrynEx®.

Printed in U.S.A.