



# HELIXX™ Stainless Steel Hopper Spreader

0.7 yd<sup>3</sup> for Half-Ton Trucks

Owner's Manual

*Original Instructions*

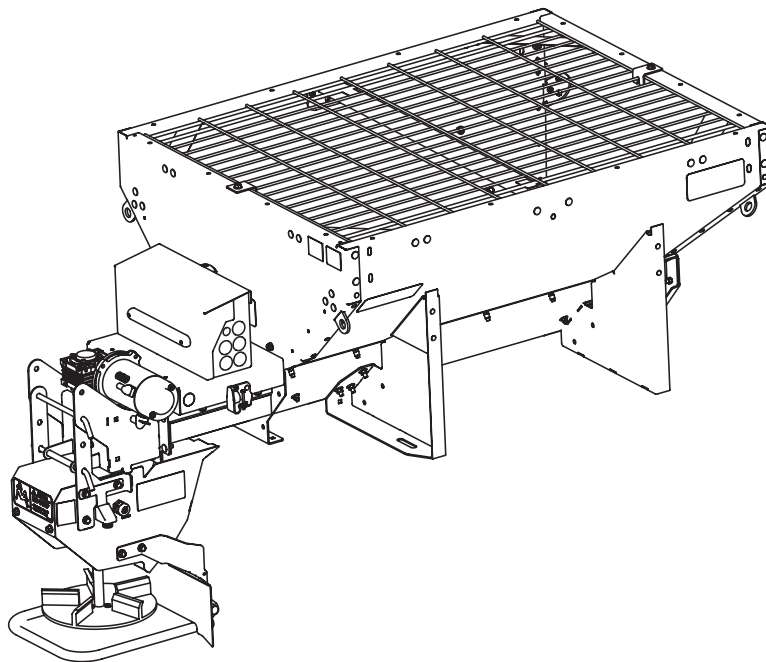

**⚠ CAUTION**

Read this document before operating  
or servicing the spreader.

This Owner's Manual is for HELIXX Hopper Spreaders  
with serial numbers beginning with 200706 and higher.

**This manual supersedes all editions with an earlier date.**



# TABLE OF CONTENTS

---

<b>SAFETY</b> .....	5	Controlling Material Application .....	21
Safety Definitions .....	5	BLAST/Maximum Application .....	22
Warning/Caution Labels .....	5	Cab Control Modes .....	22
Serial Number Label .....	9	Standby Mode .....	22
Safety Precautions .....	9	Ready Mode .....	22
Fuses .....	10	ON Mode .....	23
Personal Safety .....	10	Error Mode .....	23
Fire and Explosion .....	10	Cab Control Codes .....	24
Cell Phones .....	11	Setup Procedures .....	26
Ventilation .....	11	Calibrate the Empty Hopper Setting ( <b>Cb</b> and <b>EH</b> Codes) .....	26
Battery Safety .....	11	<b>OPERATING THE SPREADER</b> .....	27
Noise .....	11	Auto-Reverse (Ar) Feature .....	27
Vibration .....	11	Adjusting the Auto-Reverse (Ar) Setting .....	27
Torque Chart .....	11	Auto-Reverse (Ar) Sequence .....	27
<b>LOADING</b> .....	12	Spreading Tips .....	27
Certification .....	12	Accessory LED Work Light .....	28
Material Weights .....	12	Dump Function .....	28
Spreader Specifications .....	12	<b>REMOVING &amp; STORING THE SPREADER</b> .....	30
Load Volume .....	13	Remove Spreader from Vehicle .....	30
Determining Vehicle Payload .....	13	Store the Spreader .....	30
Determining Vehicle Payload Worksheet .....	14	<b>MAINTENANCE</b> .....	31
<b>UNPACKING THE SPREADER</b> .....	15	After First Use .....	31
Remove Shipping Brackets and Locate Components .....	15	After Each Use .....	31
Chute Assembly .....	15	At End of Each Season or After Extended Storage .....	31
<b>MOUNTING THE SPREADER</b> .....	16	Cab Control .....	31
Install Hopper in Vehicle Bed .....	16	Fuse Replacement .....	31
Install Tie-Down Straps .....	17	Recycle .....	31
Construct Sill Spacer .....	18	<b>ELECTRICAL COMPONENTS</b> .....	32
<b>SPINNER DRIVE ASSEMBLY</b> .....	19	Vehicle Harness Diagram .....	32
Install Spinner Drive Assembly .....	19	Electrical Control Box .....	33
<b>OPERATING THE SPREADER – CAB CONTROL</b> ..	20	<b>TROUBLESHOOTING GUIDE</b> .....	34
Powering the Control .....	20		
Starting and Stopping Spreader .....	21		

---

This manual has been prepared to acquaint you with the safety information, operation, and maintenance of your new hopper spreader. Please read this manual carefully and follow all recommendations. This will help ensure profitable and trouble-free operation of your hopper spreader. Keep this manual accessible. It is a handy reference in case minor service is required.

When service is necessary, bring your hopper spreader to your distributor. They know your spreader best and are interested in your complete satisfaction.

---

**NOTE: This spreader is designed to spread snow and ice control materials only. Do not use it for purposes other than those specified in this manual.**

---

***Register your spreader online at [www.snowexproducts.com](http://www.snowexproducts.com)***

Owner Name: \_\_\_\_\_

Date Purchased: \_\_\_\_\_

Dealer Name: \_\_\_\_\_ Phone: \_\_\_\_\_

Dealer Address: \_\_\_\_\_

Vehicle Model/Year: \_\_\_\_\_

Spreader Model/Year: \_\_\_\_\_

Spreader Length \_\_\_\_\_ Weight \_\_\_\_\_ lb/kg

Spreader Serial Number: \_\_\_\_\_

***Translated Owner's Manuals can be found online at  
<https://library.snowexproducts.com/default.asp?cat=387>***

# SAFETY

## SAFETY DEFINITIONS

### **⚠ WARNING**

Indicates a potentially hazardous situation that, if not avoided, could result in death or serious personal injury.

### **⚠ CAUTION**

Indicates a potentially hazardous situation that, if not avoided, may result in minor or moderate injury. It may also be used to alert against unsafe practices.

**NOTE:** Indicates a situation or action that can lead to damage to your spreader and vehicle or other property. Other useful information can also be described.

## WARNING/CAUTION LABELS

Become familiar with and inform users about the warning and caution labels on the spreader.

**NOTE:** If labels are missing or cannot be read, see your sales outlet.

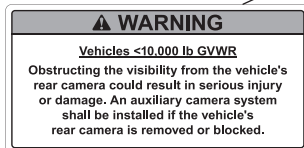
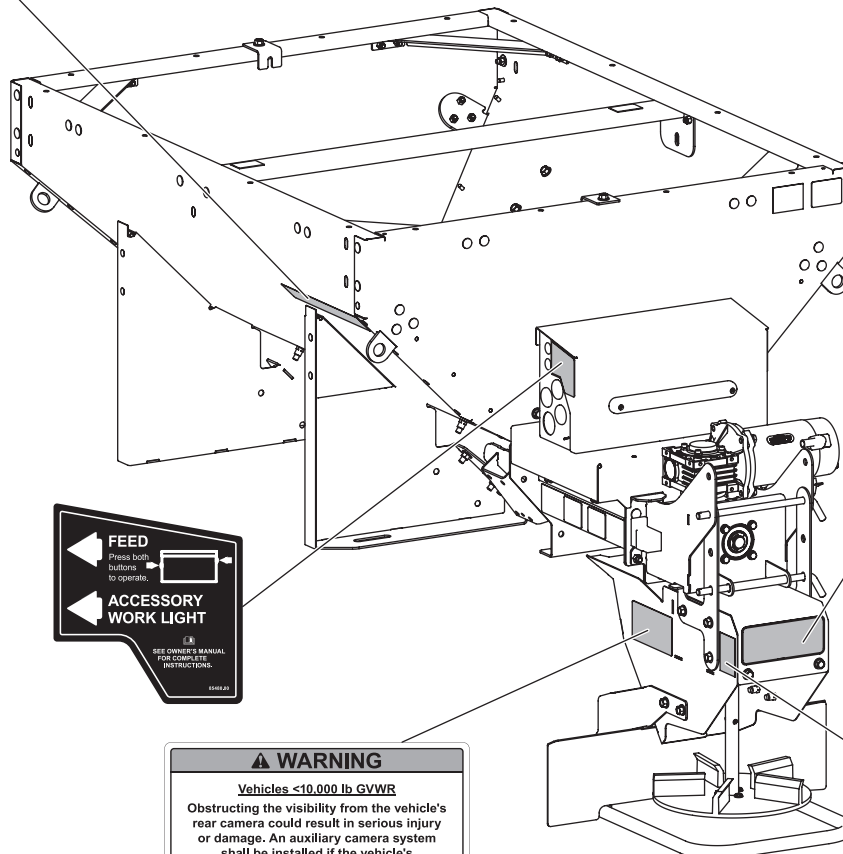
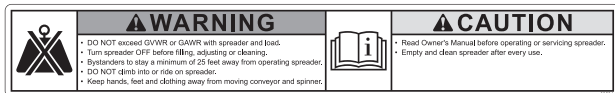

# SAFETY

## WARNING/CAUTION LABELS *continued*

**CAUTION**  
Do not lift spreader by this member.  
Lifting here could cause personal injury and property damage.

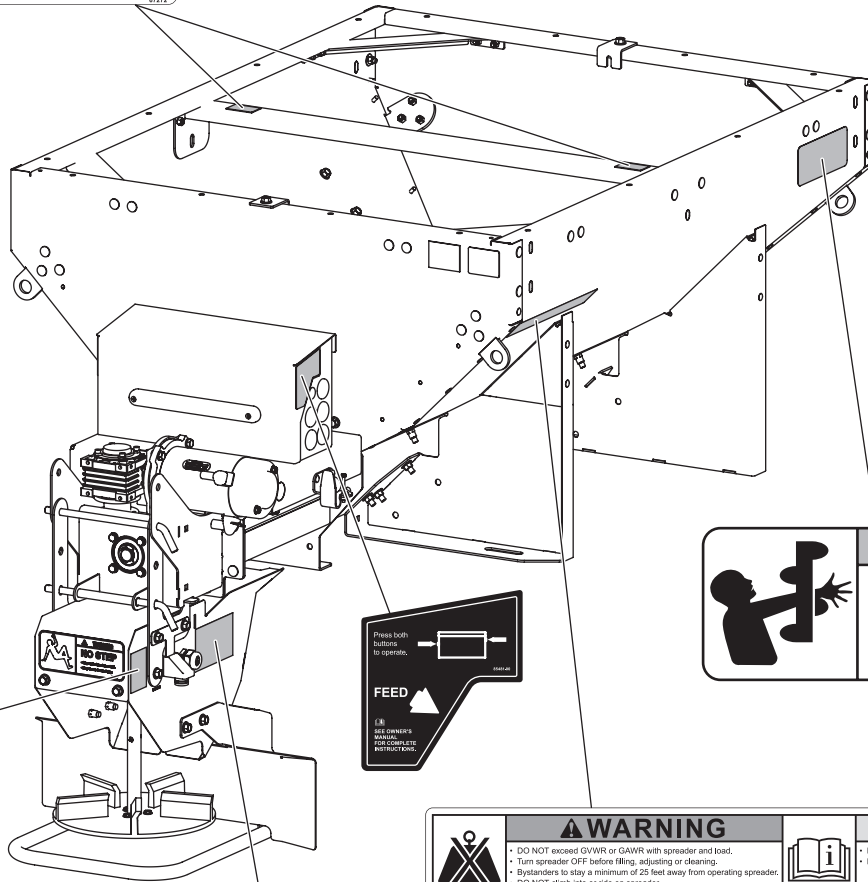

**WARNING**  
ROTATING AUGER CAN CAUSE SERIOUS INJURY OR DEATH  
• Keep arms, hands, and loose clothing away from auger.  
• Shut off control and unplug spreader before servicing.  
D6335

**WARNING**  
Multiple Pinch Points

Press both buttons to operate.  
**FEED**  
DO NOT OPERATE  
FOR CONCRETE  
SPREADERS



	<p><b>WARNING</b></p> <ul style="list-style-type: none"> <li>DO NOT exceed GVWR or GAWR with spreader and load.</li> <li>Turn spreader OFF before filling, adjusting or cleaning.</li> <li>Bystanders to stay a minimum of 25 feet away from operating spreader.</li> <li>DO NOT climb into or ride on spreader.</li> <li>Keep hands, feet and clothing away from moving conveyor and spinner.</li> </ul>		<p><b>CAUTION</b></p> <ul style="list-style-type: none"> <li>Read Owner's Manual before operating or servicing spreader.</li> <li>Empty and clean spreader after every use.</li> </ul>
--	---	--	--

**WARNING**

Disconnect spinner harness before rotating chute up for dumping or storing.

# SAFETY



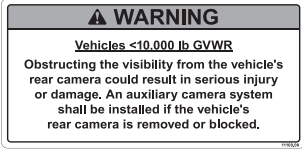

## Translation of Safety Labels

Label	Translation of Label Text
	<p style="text-align: center;"><b>WARNING</b></p> <ul style="list-style-type: none"> <li>• DO NOT exceed GVWR or GAWR with spreader and load.</li> <li>• Turn spreader OFF before filling, adjusting or cleaning.</li> <li>• Bystanders to stay a minimum of 25 feet away from operating spreader.</li> <li>• DO NOT climb into or ride on spreader.</li> <li>• Keep hands, feet and clothing away from moving conveyor and spinner.</li> </ul> <p style="text-align: center;"><b>CAUTION</b></p> <ul style="list-style-type: none"> <li>• Read Owner's Manual before operating or servicing spreader.</li> <li>• Empty and clean spreader after every use.</li> </ul>
	<p style="text-align: center;"><b>WARNING</b></p> <p>Multiple Pinch Points</p>
	<p style="text-align: center;"><b>WARNING</b></p> <p><b>No Step</b></p> <ul style="list-style-type: none"> <li>• Slippery surface when wet.</li> <li>• Falls may cause severe injury.</li> </ul>
	<p style="text-align: center;"><b>WARNING</b></p> <p><b>Vehicles &lt;10,000 lb GVWR</b></p> <p>Obstructing the visibility from the vehicle's rear camera could result in serious injury or damage. An auxiliary camera system shall be installed if the vehicle's rear camera is removed or blocked.</p>

*Continued on next page*

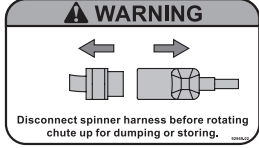
# SAFETY

## Translation of Safety Labels *continued*

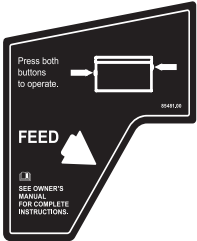
Label	Translation of Label Text
 <p><b>WARNING</b></p> <p>Disconnect spinner harness before rotating chute up for dumping or storing.</p>	<p style="text-align: center;"><b>WARNING</b></p> <p>Disconnect spinner harness before rotating chute up for dumping or storing.</p>
 <p><b>CAUTION</b></p> <p>Do not lift spreader by this member. Lifting here could cause personal injury and property damage.</p>	<p style="text-align: center;"><b>WARNING</b></p> <p>Do not lift spreader by this member. Lifting here could cause personal injury and property damage.</p>
 <p><b>WARNING</b></p> <p>ROTATING AUGER CAN CAUSE SERIOUS INJURY OR DEATH</p> <ul style="list-style-type: none"> <li>• Keep arms, hands, and loose clothing away from auger.</li> <li>• Shut off control and unplug spreader before servicing.</li> </ul>	<p style="text-align: center;"><b>WARNING</b></p> <p>ROTATING AUGER CAN CAUSE SERIOUS INJURY OR DEATH</p> <ul style="list-style-type: none"> <li>• Keep arms, hands, and loose clothing away from auger.</li> <li>• Shut off control and unplug spreader before servicing.</li> </ul>
 <p><b>FEED</b></p> <p>Press both buttons to operate.</p> <p><b>ACCESSORY WORK LIGHT</b></p> <p>SEE OWNER'S MANUAL FOR COMPLETE INSTRUCTIONS.</p>	<p><b>FEED</b></p> <p>Press both buttons to operate.</p> <p><b>ACCESSORY WORK LIGHT</b></p> <p>SEE OWNER'S MANUAL FOR COMPLETE INSTRUCTIONS.</p>
 <p>Press both buttons to operate.</p> <p><b>FEED</b></p> <p>SEE OWNER'S MANUAL FOR COMPLETE INSTRUCTIONS.</p>	<p>Press both buttons to operate.</p> <p><b>FEED</b></p> <p>SEE OWNER'S MANUAL FOR COMPLETE INSTRUCTIONS.</p>



# SAFETY

## SERIAL NUMBER LABEL

Code	Definition
YY	2-Digit Year
MM	2-Digit Month
DD	2-Digit Day
LL	2-Digit Location Code
XXXX	4-Digit Sequential Number
ZZZZZ	5- to 7-Digit Assembly Part Number



TrynEx International, LLC  
531 Ajax Drive  
Madison Heights, MI 48071

HELIXX™ 00 YD<sup>3</sup> SS HOPPER

**YYMMDDLXXXXZZZZZ**



## SAFETY PRECAUTIONS

Improper installation and operation could cause personal injury and/or equipment and property damage. Read and understand labels and the Owner's Manual before installing, operating, or making adjustments.

**⚠ WARNING**

- **Driver to keep bystanders minimum of 25 feet (7.62 m) away from operating spreader.**
- **Before working with the spreader, secure all loose-fitting clothing and unrestrained hair.**
- **Before operating the spreader, verify that all safety guards are in place.**
- **Before servicing the spreader, wait for conveyor and spinner to stop.**
- **Do not climb into or ride on spreader.**

**⚠ WARNING**



**Overloading could result in an accident or damage. Do not exceed GVWR or GAWR ratings as found on the driver-side vehicle door cornerpost. See Loading section to determine maximum volumes of spreading material.**

**⚠ WARNING**

**Do not install the control for this product in the deployment path of an air bag. Refer to vehicle manufacturer's manual for air bag deployment area(s).**

**⚠ WARNING**

**With chute removed, use dump switches to operate conveyor.**

**⚠ WARNING**

**Vehicles <10,000 lb (4536 kg) GVWR: Obstructing the visibility from the vehicle's rear camera could result in serious injury or damage. An auxiliary camera system shall be installed if the vehicle's rear camera is removed or blocked.**

# SAFETY

## CAUTION

If rear directional, CHMSL light, or brake stoplights are obstructed by the spreader, the lights shall be relocated, or auxiliary directional or brake stoplights shall be installed.

## CAUTION

During the hopper installation we recommend the addition of an OSHA compliant Backup Alarm. This alarm is required for OSHA governed employers.

## CAUTION

- Do not operate a spreader in need of maintenance.
- Before operating the spreader, reassemble any parts or hardware removed for cleaning or adjusting.
- Before operating the spreader, remove materials such as cleaning rags, brushes, and hand tools from the spreader.
- Before operating the spreader, read the engine owner's manual, if so equipped.
- While operating the spreader, use auxiliary warning lights, except when prohibited by law.
- Tighten all fasteners according to the torque chart. Refer to torque chart for the recommended torque values.

## CAUTION

Disconnect electric and/or hydraulic power and tag out if required before servicing or performing maintenance.

## CAUTION

 DO NOT leave unused material in hopper. Material can freeze or solidify, causing unit to not work properly. Empty and clean after each use.

**NOTE:** Lubricate grease fittings after each use. Use a good quality multipurpose grease.

## FUSES

The electrical system contains several blade-style automotive fuses. If a problem should occur and fuse replacement is necessary, the replacement fuse must be of the same type and amperage rating as the original. Installing a fuse with a higher rating can damage the system and could start a fire. Fuse Replacement, including fuse ratings and locations, is located in the Maintenance section of this Owner's Manual.

## PERSONAL SAFETY

- Remove ignition key and put the vehicle in PARK or in gear to prevent others from starting the vehicle during installation or service.
- Wear only snug-fitting clothing while working on your vehicle or spreader.
- Do not wear jewelry or a necktie, and secure long hair.
- Wear safety goggles to protect your eyes from battery acid, gasoline, dirt, and dust.
- Avoid touching hot surfaces such as the engine, radiator, hoses, and exhaust pipes.
- Always have a fire extinguisher rated BC handy, for flammable liquids and electrical fires.

## FIRE AND EXPLOSION

### WARNING

**Gasoline is highly flammable and gasoline vapor is explosive. Never smoke while working on vehicle. Keep all open flames away from gasoline tank and lines. Wipe up any spilled gasoline immediately.**

Be careful when using gasoline. Do not use gasoline to clean parts. Store only in approved containers away from sources of heat or flame.

# SAFETY

## CELL PHONES

A driver's first responsibility is the safe operation of the vehicle. The most important thing you can do to prevent a crash is to avoid distractions and pay attention to the road. Wait until it is safe to operate mobile communication equipment such as cell phones, text messaging devices, pagers, or two-way radios.

### ⚠ WARNING

Vehicle exhaust contains lethal fumes. Breathing these fumes, even in low concentrations, can cause death. Never operate a vehicle in an enclosed area without venting exhaust to the outside.

## VENTILATION

### ⚠ CAUTION

Batteries normally produce explosive gases which can cause personal injury. Therefore, do not allow flames, sparks, or lit tobacco to come near the battery. When charging or working near a battery, always cover your face and protect your eyes, and also provide ventilation.

- Batteries contain sulfuric acid, which burns skin, eyes, and clothing.
- Disconnect the battery before removing or replacing any electrical components.

## BATTERY SAFETY

## NOISE

Airborne noise emission during use is below 70 dB(A) for the spreader operator.









## VIBRATION

Operating spreader vibration does not exceed 2.5 m/s<sup>2</sup> to the hand-arm or 0.5 m/s<sup>2</sup> to the whole body.

## TORQUE CHART

### ⚠ CAUTION

Read instructions before assembling. Fasteners should be finger tight until instructed to tighten according to the torque chart. Use standard methods and practices when attaching spreader, including proper personal protective safety equipment.

Recommended Fastener Torque Chart					
Inch Fasteners Grade 5 and Grade 8					
Size	Torque (ft-lb)		Size	Torque (ft-lb)	
	 Grade 5	 Grade 8		 Grade 5	 Grade 8
1/4-20	8.4	11.9	9/16-12	109	154
1/4-28	9.7	13.7	9/16-18	121	171
5/16-18	17.4	24.6	5/8-11	150	212
5/16-24	19.2	27.3	5/8-18	170	240
3/8-16	30.8	43.6	3/4-10	269	376
3/8-24	35.0	49.4	3/4-16	297	420
7/16-14	49.4	69.8	7/8-9	429	606
7/16-20	55.2	77.9	7/8-14	474	669
1/2-13	75.3	106.4	1-8	644	909
1/2-20	85.0	120.0	1-12	704	995
Metric Fasteners Class 8.8 and 10.9					
Size	Torque (ft-lb)		Size	Torque (ft-lb)	
	 Class 8.8	 Class 10.9		 Class 8.8	 Class 10.9
M6 x 1.00	7.7	11.1	M20 x 2.50	325	450
M8 x 1.25	19.5	26.9	M22 x 2.50	428	613
M10 x 1.50	38.5	53.3	M24 x 3.00	562	778
M12 x 1.75	67	93	M27 x 3.00	796	1139
M14 x 2.00	107	148	M30 x 3.50	1117	1545
M16 x 2.00	167	231	M33 x 3.50	1468	2101
M18 x 2.50	222	318	M36 x 4.00	1952	2701
These torque values apply to fasteners except those noted in the instructions.					

# LOADING

This Owner's Manual covers vehicles that have been recommended for carrying the hopper spreader. Please see your local dealer for proper vehicle applications.

## CERTIFICATION

### ⚠ WARNING

New untitled vehicle installation of a spreader requires National Highway Traffic Safety Administration altered vehicle certification labeling. Installer to verify that struck load of snow or ice control material does not exceed GVWR or GAWR rating label and complies with FMVSS.

### ⚠ WARNING

Overloading could result in an accident or damage. Do not exceed GVWR or GAWR as found on the driver-side cornerpost of vehicle.

### ⚠ CAUTION

Never use wet materials or materials with foreign debris with any of these spreaders. These units are designed to handle dry, clean, free-flowing material.

### ⚠ CAUTION



Read and adhere to manufacturer's ice-control material package labeling, including Safety Data Sheet requirements.

## MATERIAL WEIGHTS

Material	Density		
	(lb/ft <sup>3</sup> )	(lb/yd <sup>3</sup> )	(kg/m <sup>3</sup> )
Salt	80	2160	1282
Sand	100	2700	1602

Material densities are approximate and are based on dry, loose material. It is the responsibility of the operator to know the weight of the material to be spread and the vehicle carrying capacity.

## SPREADER SPECIFICATIONS

Hopper Model	Overall Length	Bed Length	Empty Weight	Overall Width	Bed Height	Capacity Struck
0.7 yd <sup>3</sup>	82 in (208 cm)	54 in (137 cm)	337 lb (153 kg)	43 in (109 cm)	27.5 in (70 cm)	0.7 yd <sup>3</sup> (0.54 m <sup>3</sup> )

# LOADING

## LOAD VOLUME

Hopper Model	Load Volume (yd <sup>3</sup> )			
	A	B	C	D
0.7 yd <sup>3</sup>	0.85	0.7	0.4	0.06
	Load Volume (m <sup>3</sup> )			
	A	B	C	D
	0.65	0.54	0.31	0.05

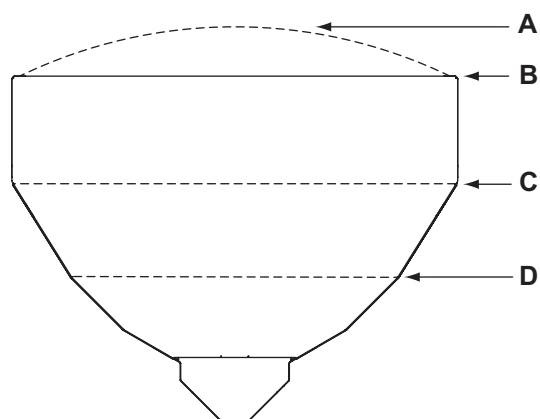

**A: Rounded Load**  
**B: Struck Load**  
**C: Third Bump**  
**D: Second Bump**

## DETERMINING VEHICLE PAYLOAD

### ⚠ WARNING

Overloading could result in an accident or damage. Do not exceed GVWR or GAWR ratings as found on the driver-side door cornerpost of the vehicle. See Loading section to determine maximum volumes of spreading material.

1. Install the hopper spreader and optional equipment according to the Installation Instructions.
2. Install or attach any other equipment that will be on the vehicle while the hopper spreader will be in use (step bumper, trailer hitch, snowplow, etc.). Fill fuel tanks.
3. Obtain the Gross Vehicle Weight Rating (GVWR), Front Gross Axle Weight Rating (FGAWR), and Rear Gross Axle Weight Rating (RGAWR) from the certification label located inside the driver-side door jamb or door.
4. With the occupants in the vehicle for normal hopper spreader operation, weigh the vehicle to obtain gross vehicle weight (GVW).
5. Subtract the GVW from the GVWR to determine the available material payload.
6. Obtain the weight per cubic yard (lb/yd<sup>3</sup>) or cubic meter (kg/m<sup>3</sup>) of the desired material. Divide the weight into the payload to determine the maximum volume of material that can be carried.
7. Refer to the Load Volume table and diagrams to determine the maximum fill level for the material.
8. Fill the hopper with material to the calculated level. Reweigh the vehicle with occupants and verify that the Loaded Gross Vehicle Weight, Front Gross Axle Weight, and Rear Gross Axle Weight are less than the vehicle's ratings.
9. Repeat Steps 6–8 for each type of material.

The worksheet for Determining Vehicle Payload (next page) includes an example.

# LOADING

## Determining Vehicle Payload Worksheet

	Material Type	<i>Example:</i> Dry Salt			
A	Equipment installed when vehicle was weighed	0.7 yd <sup>3</sup> Hopper Spreader			
B	Front Gross Axle Weight Rating [FGAWR]	6000 lb (2722 kg)			
C	Rear Gross Axle Weight Rating [RGAWR]	7000 lb (3175 kg)			
D	Gross Vehicle Weight Rating [GVWR]	11,000 lb (4990 kg)			
E	Gross Vehicle Weight [GVW], empty	- 7402 (3358 kg)			
F	Payload Available	= 3598 lb (1632 kg)			
G	Material Density	÷ 2160 lb/yd <sup>3</sup> (1282 kg/m <sup>3</sup> )			
H	Maximum Volume	= 1.67 yd <sup>3</sup> (1.27 m <sup>3</sup> )			
I	Maximum Material Fill Level, approx. Refer to Load Volume table and diagrams.	A			
J	Loaded Front Gross Axle Weight (lb/kg) Must be less than weight in Row B.				
K	Loaded Rear Gross Axle Weight (lb/kg) Must be less than weight in Row C.				
L	Loaded Gross Vehicle Weight [GVW] (lb/kg) Must be less than weight in Row D.				

# UNPACKING THE SPREADER

## REMOVE SHIPPING BRACKETS AND LOCATE COMPONENTS

The spreader is shipped from the factory with its components secured inside the hopper and the top screen in place. Before installing the spreader, remove the shipping brackets and top screen, and locate components.

1. Take off the top screen by removing the 3/8" flanged cap screws and the top screen brackets. Set the screen and all fasteners aside for reinstallation.

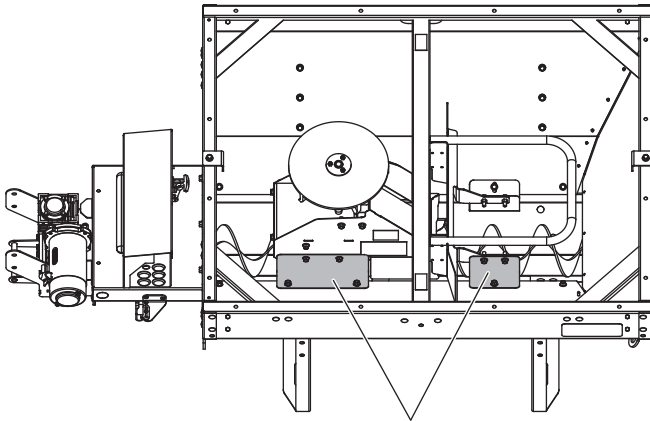

**Remove brackets.**

2. Inside the hopper, remove the 3/8" steel cap screws from the four shipping brackets (two on each side) that secure the chute enclosure and the spinner deflector assembly to the hopper for shipment. Set the chute enclosure and spinner deflector assembly aside, and discard the brackets and hardware.
3. Immediately install the six supplied 3/8" stainless steel flanged cap screws from the parts bag to fasten the hopper body to the drivetrain.

## CHUTE ASSEMBLY

1. Install four of the provided 3/8" stainless steel flanged cap screws through the spinner guard holes into the rivnuts on the chute enclosure.

**Left-Side Chute Pin Ear**

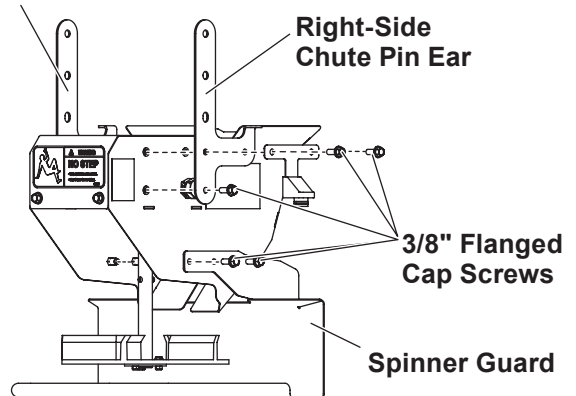

2. Remove and retain the cable boot bracket, dust cover, and fasteners. Install the left and right side chute pin ears to the chute enclosure with six provided 3/8" flanged stainless steel cap screws. Reinstall the cable boot bracket and dust cover.
3. Set chute aside for installation after the spreader has been installed on the vehicle.

# MOUNTING THE SPREADER

## INSTALL HOPPER IN VEHICLE BED

**NOTE:** Periodically throughout the snow and ice control season, verify that mounting devices are secure.

1. Remove the vehicle tailgate.
2. Remove the wood shipping rails from the hopper legs.

### ⚠ CAUTION

Before lifting, verify that the hopper is empty of material. The lifting device must be able to support the spreader's weight as shown in the Spreader Specifications table.

3. Using slings or chains, lift the spreader by all four diagonal corner rails and move it into the vehicle bed.

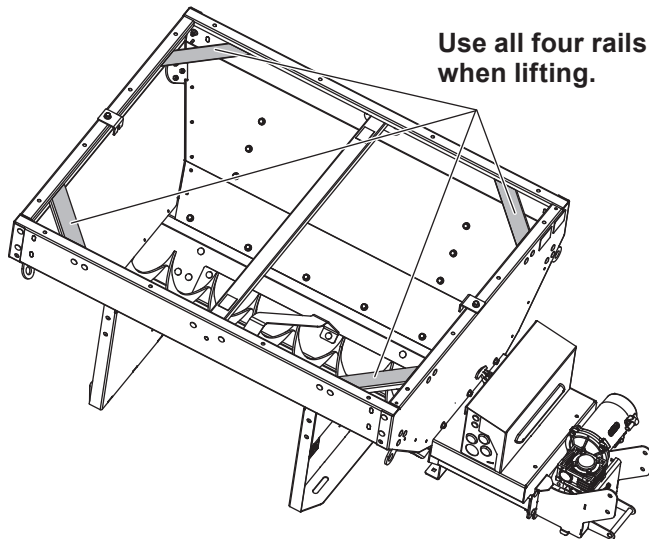

4. Center the spreader from side to side. Shift the spreader forward or backward to a position that will allow the chute, once installed, to overhang the rear of the vehicle and the bumper. With two people, trial-fit the chute to check for clearance.

5. Use the holes in the four hopper support legs as a template to mark mounting hole positions on the vehicle bed.

### ⚠ CAUTION

Before drilling holes, check to be sure that no vehicle wiring or other components could be damaged.

6. Move the spreader temporarily to allow access, and drill 5/8" holes as marked.

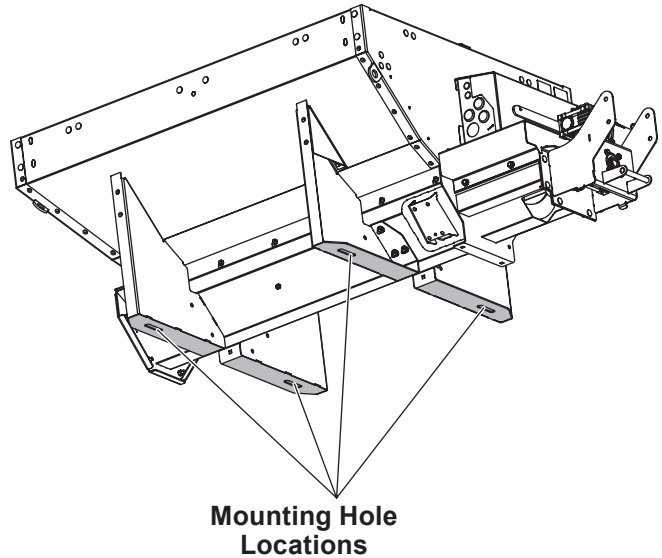

**NOTE:** Pay special attention when drilling or clamping dissimilar metals to aluminum bodies. Galvanic corrosion can occur if not handled properly. Contact vehicle manufacturer for recommended attachment practices.



# MOUNTING THE SPREADER

7. Move the spreader back into position. Secure the spreader to the vehicle with four (installer-supplied) 5/8" Grade 5 cap screws as required by the vehicle application, with 5/8" flat washers on both sides, and 5/8" locknuts.

**If the mounting holes are not directly over the vehicle box supports, the vehicle bed must be braced to the frame to prevent buckling or deforming the vehicle bed.** Accessory mounting bars are available for installations that require additional bracing. Contact your authorized dealer.

8. Remove the cable tie holding the wire harness to the conveyor chain. Connect the vehicle-side harness to the hopper-side harness.
9. Reinstall the top screen with the removed cap screws and brackets.

## Install Tie-Down Straps

### **⚠ WARNING**

**Spreader shall be bolted to vehicle frame. Do not rely on the tie-down chains or straps alone to hold spreader in vehicle.**

Install tie-down straps from the tie-down loops on the spreader body to the vehicle frame as shown. Use one strap per loop, pulling diagonally away from the hopper body.

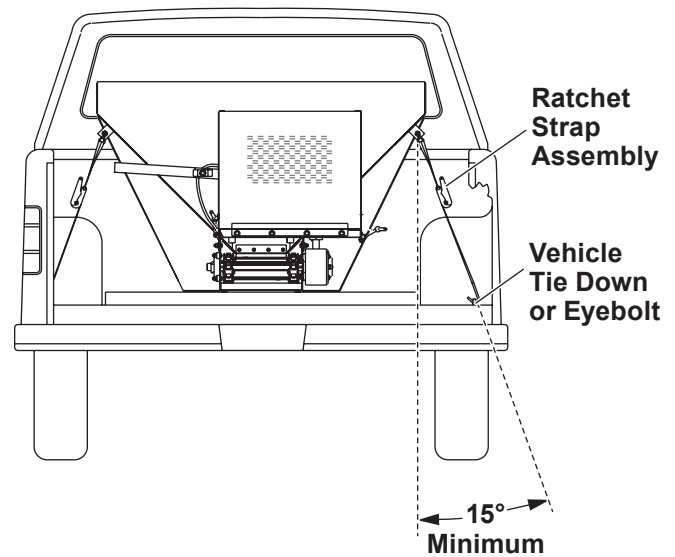

# MOUNTING THE SPREADER

## Construct Sill Spacer

Measure the distance from the front end of the hopper sill to the front of the vehicle bed and make a spacer from 2" x 8" lumber to fit that area.

**Failure to install a spacer could result in damage to the spreader.**

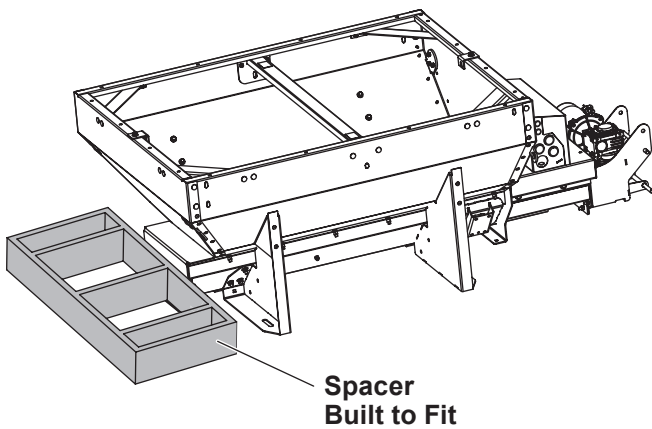
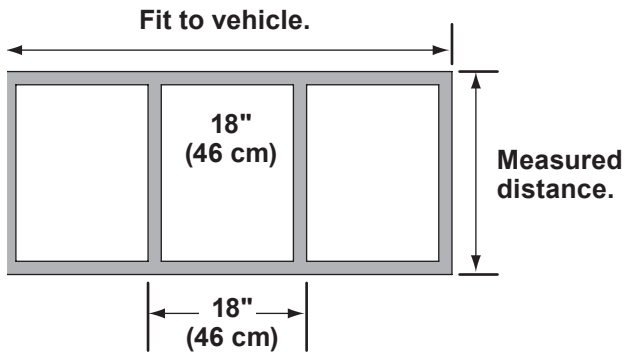
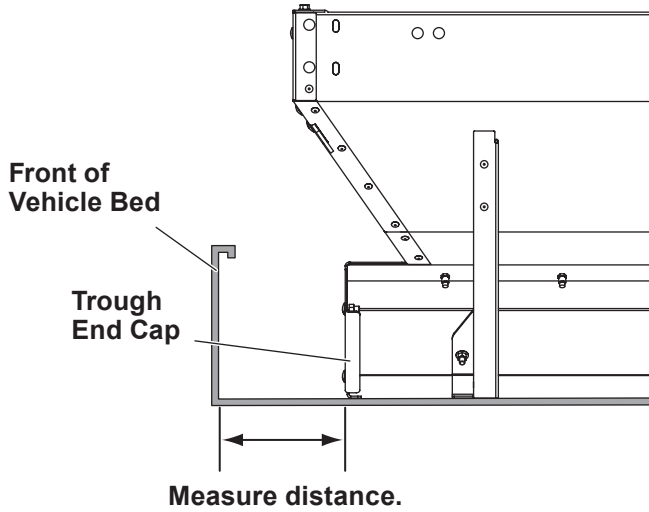

# SPINNER DRIVE ASSEMBLY

## INSTALL SPINNER DRIVE ASSEMBLY

**NOTE:** Complete the assembly installation in the Chute Assembly section before proceeding with these instructions.

1. Carefully set the spinner drive assembly on the ground. Orient it in operating position as shown below.

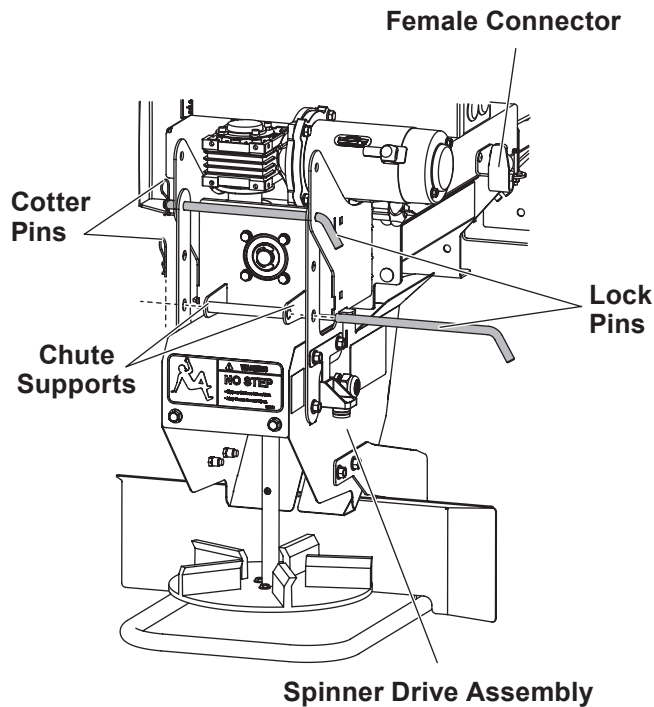

2. Attach the spinner drive assembly to the spreader with the lock pins from the parts box. *Install the upper lock pin first.*

The upper lock pin goes through the lower chute support holes and the upper chute pin ear holes.

The lower lock pin goes through the lower chute pin ear holes and the chute support.

Secure each lock pin with a cotter pin.

3. Connect the spinner motor harness to the female connector extending from the rear of the hopper.

# OPERATING THE SPREADER – CAB CONTROL

## ⚠ WARNING

Never operate equipment when under the influence of alcohol, drugs, or medications that might alter your judgment and/or reaction time.

## ⚠ WARNING

Never exceed 45 mph (72 km/h) when loaded spreader is attached to vehicle. Braking distances may be increased and handling characteristics may be impaired at speeds above 45 mph (72 km/h).

## ⚠ WARNING

Never allow children to operate or climb on equipment.

## POWERING THE CONTROL

Power is not applied to the control until the vehicle ignition is turned to ACC or ON. Once the control has power it performs a light check and displays the software version on the status display. The control then checks for a connected spreader. If no spreader is detected, the control does the following:

- **nC** (no connection) appears on the red status display for five seconds;
- A single beep;
- Control enters Standby mode with no lights illuminated.

If any button is pressed on the control, it will wake and check again for spreader connection. If no spreader is detected, it will act as described above. If a spreader is detected, it will transition to Ready mode.

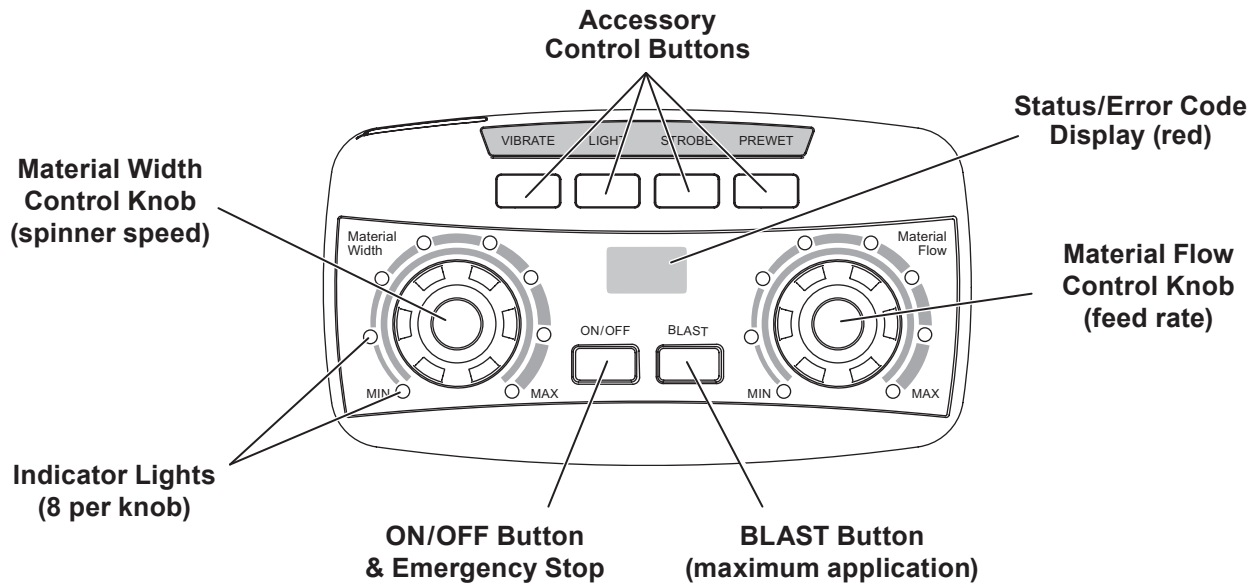

# OPERATING THE SPREADER – CAB CONTROL

---

## STARTING AND STOPPING SPREADER

### WARNING

**Before starting the spreader, the driver shall verify that all bystanders are a minimum of 25 feet (7.62 m) away from operating spreader.**

**To start the spreader**, press the ON/OFF button. The control backlights are illuminated when the vehicle ignition is ON and the spreader is connected. When the spreader is ON, the ON/OFF button and inner arc around each control knob will also illuminate.

**To stop the spreader**, press the ON/OFF button again.

The ON/OFF button also operates as an emergency stop when required.

---

**NOTE: The vehicle ignition must be ON to start the spreader.**

---

---

**NOTE: If vehicle ignition is turned OFF while spreader is running, the motors will stop.**

---

## CONTROLLING MATERIAL APPLICATION

The material application settings can be adjusted while spreader is ON or OFF. Settings are shown by the indicator lights around the control knobs. When the spreader is OFF, a single LED will light to show the current setting. When the spreader is ON, the number of blue LEDs illuminated will increase/decrease as the knobs are turned clockwise/counterclockwise.

The hopper drive will not deliver material until the ON button is pressed.

The Material Width (left) knob controls spinner speed. Turning the knob clockwise will increase the width of the application area.

The Material Flow (right) knob controls the hopper drive. Turning the knob clockwise will increase the feed rate of material to the spinner.

Turning the control knobs counterclockwise will decrease the width of the application area and the feed rate of material, respectively.

# OPERATING THE SPREADER – CAB CONTROL

---

## BLAST/Maximum Application

1. Press and hold the BLAST button when maximum flow rate and application area are needed temporarily. The BLAST button will illuminate while depressed.
2. Release the button when maximum application settings are no longer needed.

---

**NOTE: Spinner speed and material feed rate revert to the previous settings once the BLAST button is released.**

---

## CAB CONTROL MODES

### Standby Mode

Vehicle ignition is set to ACC or ON; cab control is OFF. Control has power. No spreader was detected. No lights are illuminated on the control. Press any button to wake.

### Ready Mode

Vehicle ignition is set to ACC or ON; cab control is OFF. Control has power. Spreader is detected.

The Material Width and Material Flow control knobs can be set to start-up conditions, but the spinner and drives will not operate until the cab control is turned ON.

Accessory lights and vibrator (if installed) are operational. The BLAST function is not operational.

# OPERATING THE SPREADER – CAB CONTROL

---

## ON Mode

Vehicle ignition is set to ACC or ON; cab control is ON.

Spinner and hopper motors will start. All cab control functions are operational. Accessory lights and vibrator (if installed) are operational.

During normal spreader operation, **no control codes are displayed**. Information or setup codes will appear when relevant. These codes will not stop spreader operation.

## Error Mode

When an error condition occurs, spreader operation will shut down. A two-character error code will flash on the display and a beep will sound. If there are multiple error codes, the codes will flash in a repeating sequence.

Refer to the Error Codes portion of the following Cab Control Codes table. Also see the Troubleshooting Guide section of this manual.

Once the error condition has been resolved, press the ON/OFF button to clear the error code(s). Press the ON/OFF button again to resume spreader operation.

The error code will reappear if the error condition has not been rectified. If the error condition persists, contact your authorized dealer.

Multiple resets within a short time frame will cause the hopper module to time out if components are overheating. The control will display an **EF** error code.

Accessory work lights and strobe lights can be used when an error code is in effect and will remain in their current state. The vibrator and pre-wet, if installed, will not function.

# OPERATING THE SPREADER – CAB CONTROL

## CAB CONTROL CODES

Setup Codes		
Code	Definition	Procedure
<b>Cb</b>	Calibrate the Empty Hopper setting.	With control in ON mode, press and hold the left control knob until the <b>Cb</b> code displays. Calibration cycle is automatic.*
<b>Cc</b>	Clear calibration data for Empty Hopper setting; clear <b>EH</b> code.	Press the right control knob to clear all calibration data during the calibration cycle.
<b>LS</b>	Set LED brightness level.	With control in Ready mode, press and hold the left control knob to get <b>LS</b> code. Release pressure and turn the left control knob to desired brightness setting. Wait for confirming <b>SL</b> code to display.*
<b>SL</b>	Confirms that LED brightness level has been reset.	

\* For full instructions, see "Setup Procedures" in the Operating the Spreader – Cab Control section of this manual.

Information Codes		
Code	Definition	Response
<b>Ar</b>	Auto-reverse sequence is active.	The spreader will automatically detect and attempt to clear a jam. See the Operating the Spreader section of this manual.
<b>dU</b>	Spreader is in dump mode: <ul style="list-style-type: none"> <li>• Spinner drive assembly is removed.</li> <li>• Material Feed buttons are enabled.</li> </ul>	To operate the dump function, see instructions in the Operating the Spreader section of this manual. If <b>dU</b> code displays when the spinner drive assembly harness is attached, contact authorized dealer.
<b>EH</b>	Empty hopper (beep will sound).	Check hopper for material. Recalibrate Empty Hopper setting as described above for <b>Cb</b> code.
<b>Lb</b>	Low battery. Hopper module is sensing <10V. ( <b>Lb</b> becomes an error code when module senses ≤6V.)	Refer to the <b>Lb</b> row under "Error Codes" (next table).

Error Codes – Spreader Operation Stopped			
Code	Definition	Possible Cause	Suggested Solution
<b>bb</b>	Bad button.	Button is stuck. Button was pressed while vehicle ignition was entering ACC or START mode.	Inspect control. Free up button. Do not press any spreader cab control buttons while the vehicle ignition is being engaged.
<b>bH</b>	Bad hopper.	Possible module or control mismatch.	Replace control or module. Use only genuine service parts. Contact authorized dealer.
<b>CE</b>	No communication with spreader module.	Loose connection. Module lost power. Disconnected spreader harness while vehicle is ON.	Confirm that spreader and control harnesses are connected to the vehicle harness. Check power to spreader module, all connections, fuses, and power studs. Check that port B is plugged in.
<b>CP</b>	Spinner drive assembly present fault.	Spinner drive assembly harness is not attached.	Install the spinner drive assembly harness. Reset the control by pressing the ON/OFF button.
<b>Ct</b>	Control is hot.	Cab temperature is too high. Control overheated.	Turn OFF spreader and allow control to cool off.
<b>EF</b>	Excessive drive faults.	Too many <b>HO</b> and/or <b>SO</b> error codes; hopper module overheating.	Control times out for 60 seconds. Ensure that the auger and/or spinner are not jammed.

*Table continues on next page.*



# OPERATING THE SPREADER – CAB CONTROL

## CAB CONTROL CODES *continued*

<b>Error Codes – Spreader Operation Stopped</b>			
<b>Code</b>	<b>Definition</b>	<b>Possible Cause</b>	<b>Suggested Solution</b>
<b>HO</b>	Hopper overload – software trip.	Drive system has high current. Material is jammed.	Inspect auger; clear material jam, or fix auger as needed.
<b>HO.</b>	Hopper overload – hardware trip.	Auger is damaged.	
<b>HP</b>	Hopper power issue. No motor present.	Hopper drive motor is not connected. Possible motor defect.	Check connections to the auger drive motor (P-FEED and FEED-N posts on the module and studs on the motor). Replace the motor.
<b>Lb</b>	Low battery. Hopper module is sensing $\leq 6V$ .	Bad connection or low battery. Snowplow or other vehicle power use may be driving down voltage.	Voltage is measured at the hopper module; therefore, <b>Lb</b> code may indicate cable voltage loss. Check battery, alternator, and connections.
<b>nC</b>	No connection.	Spreader not connected to vehicle harness.	Connect vehicle and spreader harness. Check vehicle harness fuse. Inspect spreader and vehicle harnesses. Check module.
<b>OH</b>	Overheating.	Spreader module is too hot.	Allow a cool-off period of 60 seconds or longer. Check for loose harness connections. Check accessory connections. Check integrity of accessory wiring and harness. Clear jammed material. Contact authorized dealer.
<b>OH.</b>	Overheating module – microprocessor.	Spreader module malfunction. Accessories wiring/function problem. Drive motor overload.	
<b>rS</b>	Reset of spreader module.	Power loss to module detected on startup.	Reset the control by pressing the ON/OFF button. Check vehicle harness and battery connections.
<b>SO</b>	Spinner drive overload – software trip.	Material jammed in spinner. Spinner shaft is damaged.	Inspect spinner and spinner drive components for alignment and condition.
<b>SO.</b>	Spinner drive overload – hardware trip.		
<b>SP</b>	Spinner power issue. No motor present.	Spinner drive motor is not connected. Possible motor defect.	Check connections to the motor (SPIN and GND posts on the module). Replace the motor.

# OPERATING THE SPREADER – CAB CONTROL

---

## SETUP PROCEDURES

### Calibrate the Empty Hopper Setting (Cb and EH Codes)

Calibrating the empty hopper setting enables the cab control to alert the operator when the hopper is empty.

Recalibrate the empty hopper setting at the start of each ice-control season.

1. Ensure that the hopper is empty before beginning the calibration.
2. Turn the vehicle ignition to ACC or ON. Press the ON/OFF button on the cab control to turn the control ON.
3. Press and hold the Material Width (left) knob for approximately 10 seconds until the **Cb** code displays.
4. The calibration cycle will begin. The blue LEDs around the Material Flow (right) knob will illuminate in succession until all eight are lit.
5. When the automatic calibration cycle is complete, the control will automatically revert to the previous material application settings.

If the control is turned OFF or loses power during the calibration cycle, the calibration data will be lost. Make sure the control is ON and restart the calibration process at Step 3.

Once the empty hopper setting has been calibrated, the **EH** code will flash on the display and a beep will sound whenever the hopper is empty. The **EH** code is informational only and will not stop spreader operation.

### Clearing Empty Hopper Calibration Data (Cc Code)

The empty hopper calibration may be cleared, if desired. The control will no longer display the **EH** status code when the hopper is empty.

Start the calibration cycle as described above. At Step 4, press the Material Flow (right) knob during the calibration cycle to clear *all* calibration data. The **Cc** (Clear Calibration) code will display and the control will exit **Cc** mode automatically.

### Adjust LED Brightness Level (LS and SL Codes)

The brightness setting of the cab control lights can be adjusted from 1 to 16. The factory default setting is 8.

1. Turn the vehicle ignition to ACC or ON. If necessary, press the cab control ON/OFF button to turn the control OFF.
2. Press and hold the Material Width (left) knob for approximately 3 seconds until the **LS** code is displayed.
3. Release the knob and turn it clockwise or counterclockwise to increase/decrease the brightness level. The light level number will show in the status display.
4. After selecting the desired brightness level, wait a few seconds for the **SL** confirmation code to display.

---

**NOTE: A brightness level setting of 12 or higher is recommended for daylight conditions.**

---

# OPERATING THE SPREADER

---

## AUTO-REVERSE (Ar) FEATURE

The spreader is automatically able to sense and clear material jams. The sensitivity level of the auto-reverse feature is adjustable.

### Adjusting the Auto-Reverse (Ar) Setting

1. With the spreader connected and the control powered up in the READY mode, press and hold the BLAST button. After 5 seconds, a number will appear on the status display (factory default is 20).
2. Continue to hold the BLAST button and turn the right-hand knob to control the material flow setting (range is 2–30). Turn the knob clockwise to increase the flow. Turn the knob counterclockwise to decrease the flow.
3. Release the BLAST button.
4. Press the ON/OFF button twice (turning the spreader ON, and then OFF) to save the setting.
5. If auto-reverse is too sensitive or not sensitive enough, repeat Steps 1–4 and adjust the value. If the value is set to 30, the auto-reverse feature will be disabled.

### Auto-Reverse (Ar) Sequence

The **Ar** sequence will begin automatically and consist of a series of reverse-then-forward movements of the auger.

The **Ar** sequence will make up to five attempts to clear the jam. The status display will flash **Ar** then a number, and repeat as it counts down from 5 to 1. If the jam is cleared, the auger will automatically return to normal operation at the previous control settings.

### **⚠ CAUTION**

**Disconnect electric power and tag out, if required, before servicing or performing maintenance.**

If auto-reverse is unsuccessful, then the operator must extract the material that is causing the problem. Follow all warning directions when clearing jams.

### SPREADING TIPS

- Spread ice melters with the storm to prevent unmanageable levels of ice.
- Never exceed 10 mph (16 km/h) when spreading.
- For a wider pass, increase spinner speed.
- For a heavier pass, drive slower or increase auger speed.
- Never operate spreader near pedestrians.
- Calculate spread pattern when near vegetation.

---

**NOTE: The spinner motor is not designed for continuous duty. Allow the motor to cool between long cycle times.**

---

# OPERATING THE SPREADER

---

## ACCESSORY LED WORK LIGHT

The accessory work light can be purchased through your authorized dealer. Follow the work light Installation Instructions to wire the accessory work light to the button on the electrical box.

A second LED light and harness can be also be added. Accessory work light kits are available through your authorized dealer.

## DUMP FUNCTION

The dump function allows the operator to activate the material feed to empty the hopper after use or load material into a walk-behind spreader.

The dump function is a two-handed operation requiring the operator to press two buttons at the same time. The material feed buttons are located on driver's side of the electrical enclosure at the hopper rear. The spinner motor harness must be disconnected to enable the dump function.

1. Disconnect the spinner motor harness.
2. Remove the *bottom* cotter pin and locking pin from the spinner drive assembly and chute supports.
3. Rotate the spinner drive assembly upward, and secure it raised position by reinserting the locking pin through the *top* hole in the chute supports and spinner drive assembly.

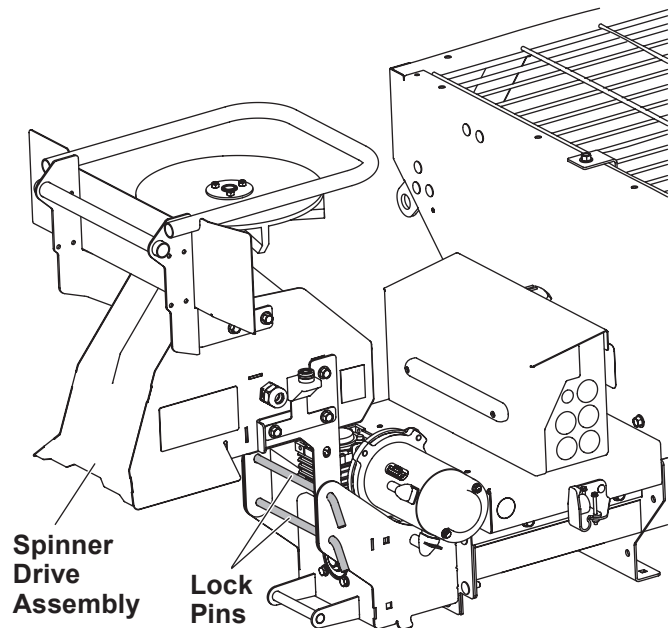

## OPERATING THE SPREADER

---

4. Insert the cotter pin into the locking pin.
5. Position the material receptacle or walk-behind spreader under the end of the hopper.
6. Press and hold both material feed buttons to operate the auger.

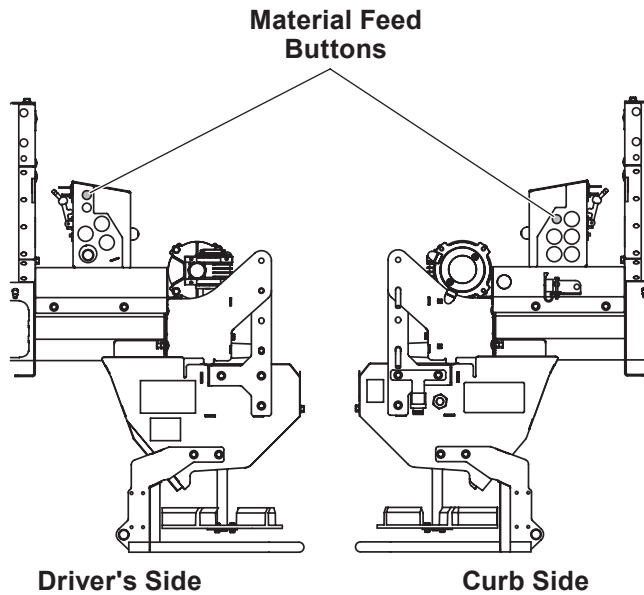

---

**NOTE: Do not stand directly in front of the auger when operating the dump function.**

---

7. To stop the auger, release one or both of the material feed buttons.

# REMOVING & STORING THE SPREADER

## ⚠ WARNING

Never remove the spreader with material in the hopper.

## REMOVE SPREADER FROM VEHICLE

1. Disconnect the vehicle-side harness from the hopper-side harness.
2. Remove both cotter pins and locking pins. Remove the spinner drive assembly from the hopper and set it aside.
3. Remove the frame spacer from in front of the hopper and set it aside.
4. Remove the hopper mounting hardware from the frame mounting holes and tie-down straps.

## ⚠ CAUTION

Before lifting, verify that the hopper is empty of material. The lifting device must be able to support the spreader's weight as shown in the Spreader Specifications table.

5. Lift the spreader and remove it from the vehicle.  
**To lift the spreader**, remove the top screen. Using slings or chains, lift the spreader by the four diagonal corner rails.

Use all four rails when lifting.

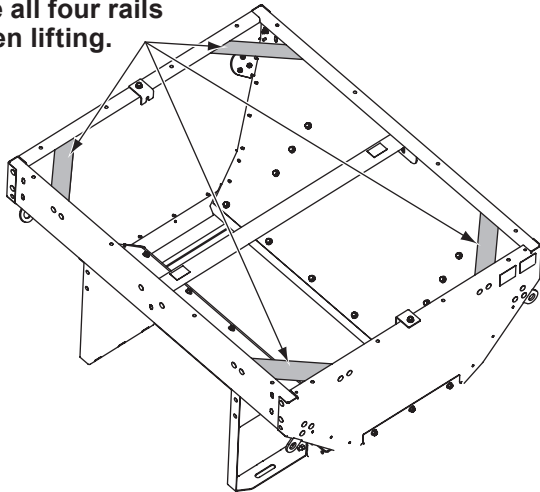

## STORE THE SPREADER

The spreader can be stored in vehicle position on blocks or stands. Make sure the supports are stable and the ground beneath is firm enough that the spreader will not shift over time.

1. Remove the chute from the hopper body. Store the chute in a horizontal position. It may be placed inside or on top of the hopper if desired.

## ⚠ CAUTION

Before lifting, verify that the hopper is empty of material. The lifting device must be able to support the spreader's weight as shown in the Spreader Specifications table.

2. Remove the hopper mounting bolts and tie-downs.
3. Attach slings to the four corner lift points and, using a hoist, lift the hopper out of the vehicle. Move the spreader to the storage location with the hoist or lower it onto blocks and use a forklift to move it to a secure location.
4. The hopper body should be slightly tilted toward the chute end to prevent any rainwater from pooling in the hopper.
5. Use blocking to ensure that the spreader is stable.

# MAINTENANCE

---

## CAUTION

Disconnect electric power at spreader electrical wiring harness connection and tag out, if required, before servicing or performing maintenance.

### AFTER FIRST USE

Tighten all mounting fasteners.

### AFTER EACH USE

## CAUTION



**DO NOT** leave unused material in hopper. Material can freeze or solidify, causing unit to not work properly. Empty and clean after each use.

- Wash the unit after each use to prevent material build-up and corrosion.
- Apply dielectric grease on all electrical connections to prevent corrosion.

### AT END OF EACH SEASON OR AFTER EXTENDED STORAGE

---

**NOTE: The 99067 and 10923 gear box is lubricated for life and does not require oil changes.**

---

- Apply dielectric grease on all electrical connections to prevent corrosion at the beginning and end of the season and each time the power plugs are disconnected.
- Wash out the hopper and rinse off all external surfaces to prevent material build-up and corrosion.
- Paint or oil all bare metal surfaces at the end of the season.
- Apply a small amount of light oil to latches as needed.

### CAB CONTROL

Unplug the cab control from the control harness at the end of the season or when the hopper is removed from the vehicle.

### FUSE REPLACEMENT

If a problem should occur and fuse replacement is necessary, the replacement fuse must be of the same type and amperage rating as the original. Installing a fuse with a higher rating can damage the system and could start a fire.

### RECYCLE

When your spreader has performed its useful life, many of its components can be recycled.

# ELECTRICAL COMPONENTS

## VEHICLE HARNESS DIAGRAM

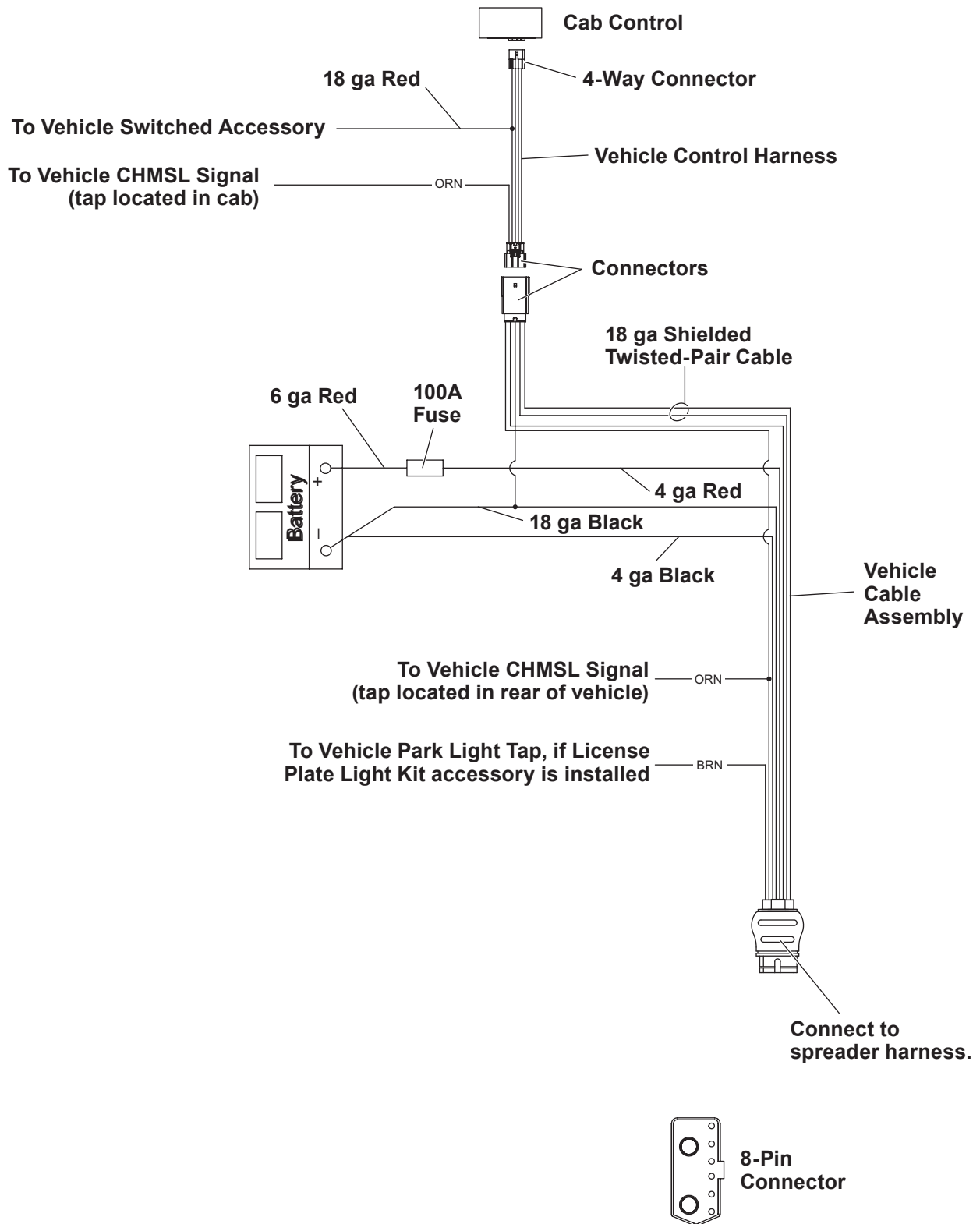



# ELECTRICAL COMPONENTS

## ELECTRICAL CONTROL BOX

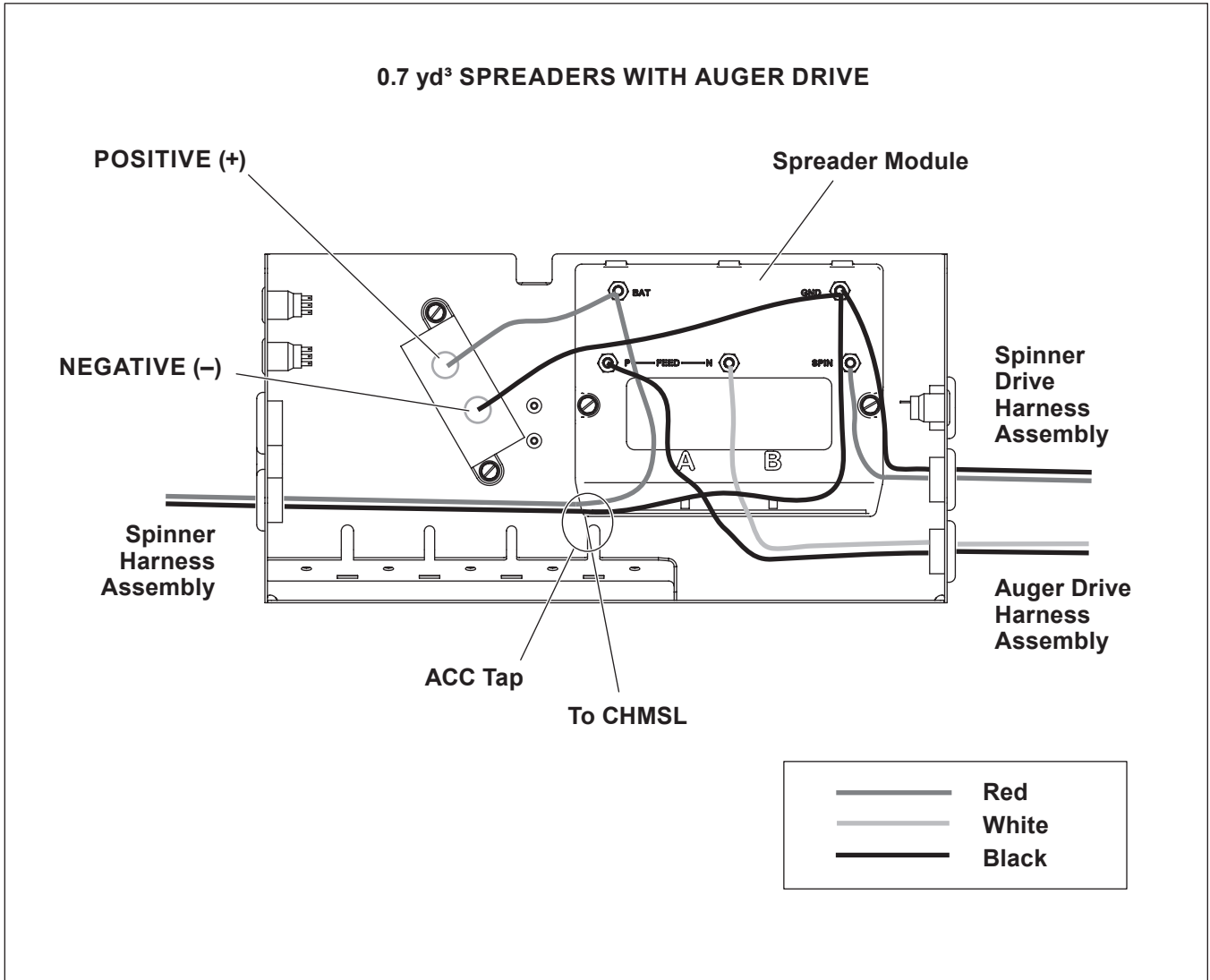

## TROUBLESHOOTING GUIDE

Please see your authorized dealer for service. The troubleshooting reference table below may guide you in diagnosing the issue.

For a reference table of the cab control error codes, see the Operating the Spreader – Cab Control section of this manual.

Before servicing the spreader:

- Review all safety information.
- Confirm that all electrical connections are tight and clean.
- Confirm that nothing is jammed in the hopper.

Problem	Possible Cause	Suggested Solution
<b>No power to cab control.</b> Ignition and control switches ON; control knob indicator lights not illuminated.	1. Control is in Standby mode. Spreader is not connected.	1. Press any button on control to wake.
	2. Control connector plug is loose.	2. Check plug connection at cab control.
	3. Switched accessory connection is poor or faulty battery.	3a. Check for low battery. 3b. Check switched accessory connection.
	4. Blown fuse.	4. Replace spreader vehicle battery cable fuse.
	5. Vehicle control harness is damaged.	5. Repair or replace damaged wires or harness as required.
<b>Turning control knobs does not change motor speed.</b>	1. Malfunctioning cab control.	1. Replace cab control.
	2. Malfunctioning spreader module.	2. Replace spreader module.
<b>Spreader does not operate.</b>	1. Overloaded condition is causing over-current protection to activate.	1. Reset cab control by pressing the ON/OFF switch.
	2. Wire harness is damaged or has an open circuit between cab control and spreader.	2a. Check plug connections at cab control and spreader. 2b. Check wire connections at spreader motor and at vehicle battery: disconnect motor leads, turn Material Width and Material Flow knobs to maximum, and check for voltage at motor leads. 2c. Repair or replace damaged wires and connectors. 2d. Check the 100A in-line fuse on the 22" red cable. Replace if necessary.

# TROUBLESHOOTING GUIDE

---

*This page intentionally left blank.*



TrynEx International, LLC  
531 Ajax Drive  
Madison Heights, MI 48071-2429  
[www.snowexproducts.com](http://www.snowexproducts.com)

 A DIVISION OF DOUGLAS DYNAMICS, LLC



*This product conforms to EU Machinery Directive 2006/42/EC, The Restriction of the Use of Certain Hazardous Substances in Electrical and Electronic Equipment - Directive 2011/65/EU (RoHS2).*



*This product conforms to the UK Supply of Machinery (Safety) Regulations 2008, The Restriction of the Use of Certain Hazardous Substances in Electrical and Electronic Equipment Regulations 2012 (RoHS2).*

Copyright © 2022 Douglas Dynamics, LLC. All rights reserved. This material may not be reproduced or copied, in whole or in part, in any printed, mechanical, electronic, film, or other distribution and storage media, without the written consent of TrynEx International, LLC. Authorization to photocopy items for internal or personal use by TrynEx International outlets or spreader owner is granted.

TrynEx International reserves the right under its product improvement policy to change construction or design details and furnish equipment when so altered without reference to illustrations or specifications used. TrynEx International or the vehicle manufacturer may require or recommend optional equipment for spreaders. Do not exceed vehicle ratings with a spreader. This product is manufactured under the following U.S. patents: 7,400,058, and other patents pending. TrynEx International offers a limited warranty for all spreaders and accessories. See separately printed page for this important information. The following are registered (®) or unregistered (™) trademarks of Douglas Dynamics, LLC: HELIXX™.

**Printed in U.S.A.**